



XS Wireless Series

PDF export of the original HTML manual



Contents

1. Preface.....	4
2. Product information.....	5
Products of the XS Wireless series.....	5
EM-XSW 1 stationary receiver.....	5
EM-XSW 1 DUAL rack receiver.....	6
EM-XSW 2 stationary receiver.....	7
SKM XSW handheld transmitter.....	8
SK-XSW bodypack transmitter.....	9
Accessories.....	10
Frequency ranges.....	12
3. Instruction manual.....	13
EM-XSW 1 rack receiver.....	13
Product overview.....	13
Connecting/disconnecting the receiver to/from the power supply system.....	15
Outputting audio signals.....	16
Switching the receiver on and off.....	17
Information on the receiver's display.....	18
Setting options on the front of the device.....	19
Setting options on the rear of the device.....	22
Configuring a multi-channel system.....	24
EM-XSW 1 DUAL rack receiver.....	25
Product overview.....	25
Connecting/disconnecting the receiver to/from the power supply system.....	27
Outputting audio signals.....	28
Switching the receiver on and off.....	29
Information on the receiver's display.....	30
Setting options on the front of the device.....	32
Setting options on the rear of the device.....	36
Configuring a multi-channel system.....	38
EM-XSW 2 rack receiver.....	39
Product overview.....	39
Connecting/disconnecting the receiver to/from the power supply system.....	42
Connecting antennas.....	43
Outputting audio signals.....	44
Installing receivers in a rack.....	45



Switching the receiver on and off.....	47
Information on the receiver's display.....	48
Setting options on the front of the device.....	50
Setting options on the rear of the device.....	56
Configuring a multi-channel system.....	58
SKM XSW handheld transmitters.....	59
Product overview.....	59
Inserting and removing the batteries.....	60
Switching the handheld transmitter on and off.....	62
Establishing a connection to the receiver.....	63
Information on the handheld transmitter's display.....	64
Setting the input sensitivity.....	65
Muting the handheld transmitter.....	66
SK-XSW bodypack transmitter.....	67
Product overview.....	67
Inserting and removing the batteries.....	69
Connecting a microphone to the bodypack transmitter.....	71
Connecting an instrument or line source to the bodypack transmitter.....	72
Switching the bodypack transmitter on and off.....	73
Establishing a connection to the receiver.....	74
Information on the handheld transmitter's display.....	75
Setting the input sensitivity.....	76
Muting the bodypack transmitter.....	77
Establishing a radio link Synchronizing the receiver and transmitter.....	78
Cleaning and maintenance.....	81
4. Specifications.....	82
System.....	82
EM-XSW 1 stationary receiver.....	84
EM-XSW 1 DUAL rack receiver.....	85
EM-XSW 2 stationary receiver.....	86
SKM-XSW handheld transmitter.....	87
SK-XSW bodypack transmitter.....	89
5. Regulatory information.....	90



1. Preface

PDF Export of the Original HTML Manual

This PDF document is an automatic export of an interactive set of HTML manuals. Some content and interactive elements may not be included in the PDF because they cannot be displayed in this format. In addition, automatically generated page breaks may cause related content to be slightly shifted. We can therefore only guarantee the completeness of the information in the HTML manual and recommend using it. You can find it in the Documentation Portal at www.sennheiser.com/documentation.



2. Product information

All information about the product, the scope of delivery and the available accessories.

Products of the XS Wireless series

EM-XSW 1 stationary receiver



i You can find more detailed information about the EM-XSW 1 in the following sections:

- **Startup and operation:** [EM-XSW 1 rack receiver](#)
- **Specifications:** [EM-XSW 1 stationary receiver](#)



EM-XSW 1 DUAL rack receiver



i You can find more detailed information about the EM-XSW 1 Dual in the following sections:

- **Startup and operation:** [EM-XSW 1 DUAL rack receiver](#)
- **Specifications:** [EM-XSW 1 DUAL rack receiver](#)



EM-XSW 2 stationary receiver



i You can find more detailed information about the EM-XSW 2 in the following sections:

- **Startup and operation:** [EM-XSW 2 rack receiver](#)
- **Specifications:** [EM-XSW 2 stationary receiver](#)



SKM XSW handheld transmitter



The handheld transmitter is available in the following versions:

- SKM 825-XSW
- SKM 835-XSW
- SKM 865-XSW

i You can find more detailed information about the SKM XSW in the following sections:

- **Startup and operation:** [SKM XSW handheld transmitters](#)
- **Specifications:** [SKM-XSW handheld transmitter](#)



SK-XSW bodypack transmitter



i You can find more detailed information about the SK-XSW 1 in the following sections:

- **Startup and operation:** [SK-XSW bodypack transmitter](#)
- **Specifications:** [SK-XSW bodypack transmitter](#)



Accessories

GA 1-XSW 2 rack mount kit

19" rack adapter for mounting the EM-XSW 2 in a 19" rack.

Art. no. 507351



GA 2-XSW 2 antenna front mount kit

Antenna front mount kit for installing antenna connections on the front of the rack when using the EM-XSW 2 together with the GA 1-XSW 2 rack mount kit.

Art. no. 507468





Frequency ranges

The products are available in the following frequency ranges.

i Frequency tables with the factory presets for all available frequency ranges can be found in the download area of the Sennheiser website at: sennheiser.com/download

i Conditions and restrictions for using frequencies
There may be special conditions and restrictions for using frequencies in your country.
Before putting the product into operation, find the information for your country at the following address: sennheiser.com/sifa.



3. Instruction manual

Starting up and operating devices of the XS Wireless series.

EM-XSW 1 rack receiver

Product overview

Front

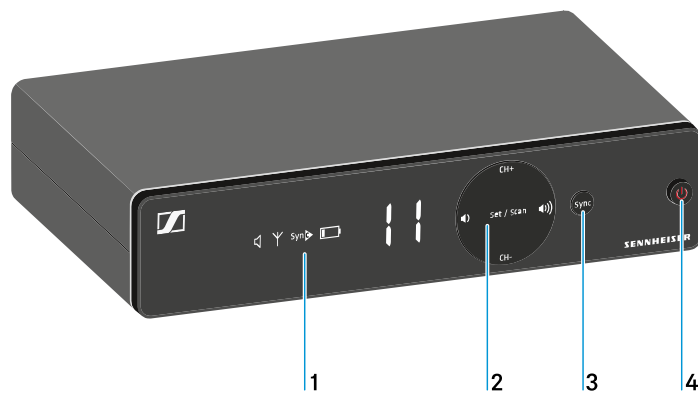

1 Display for status information

- see [Information on the receiver's display](#)

2 Control buttons for selecting channels and adjusting volume

- see [Setting options on the front of the device](#)

3 **SYNC** button for synchronizing the transmitter and receiver

- see [Establishing a radio link | Synchronizing the receiver and transmitter](#)

4 **ON/OFF** button for switching the device on and off

- see [Switching the receiver on and off](#)



Back

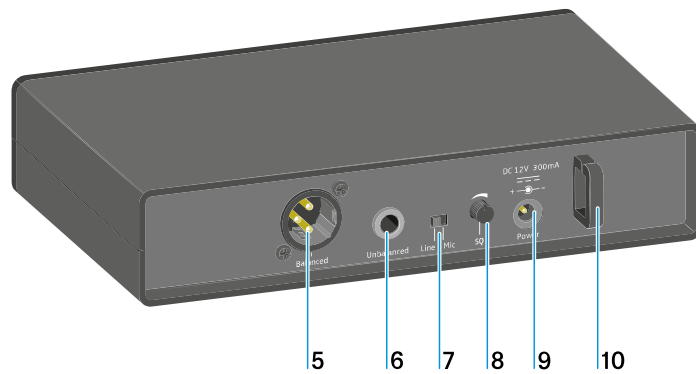

5 XLR-3 socket for **Balanced** audio output

- see [Outputting audio signals](#)

6 6,3 mm jack socket for **Unbalanced** audio output

- see [Outputting audio signals](#)

7 **Line/Mic** switch for selecting the signal type

- see [Setting options on the rear of the device](#)
- see [Outputting audio signals](#)

8 SQ control knob for adjusting the squelch value

- see [Setting options on the rear of the device](#)

9 Power connection socket for the power supply unit

- see [Connecting/disconnecting the receiver to/from the power supply system](#)

10 Strain relief for the connection cable of the power supply unit

- see [Connecting/disconnecting the receiver to/from the power supply system](#)



Connecting/disconnecting the receiver to/from the power supply system

Only use the supplied power supply unit. It is designed for your receiver and ensures safe operation.

To connect the receiver to the power supply system:

- ▶ Pass the cable of the power supply unit through the strain relief.
- ▶ Insert the plug of the power supply unit into the Power socket on the receiver.
- ▶ Slide the supplied country adapter onto the power supply unit.
- ▶ Plug the power supply unit into the wall socket.

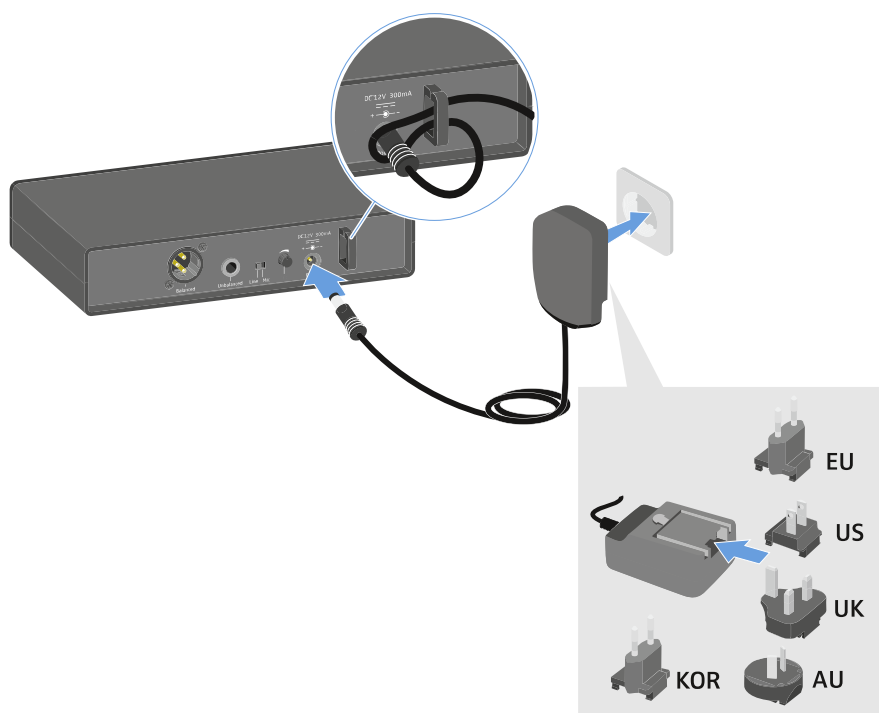

To completely disconnect the receiver from the power supply system:

- ▶ Unplug the power supply unit from the wall socket.
- ▶ Unplug the power supply unit from the Power socket on the receiver.



Outputting audio signals

The EM-XSW 1 has a balanced XLR-3M output socket and an unbalanced 6.3 mm jack output socket.

- ▶ Always use only one of the two output sockets.

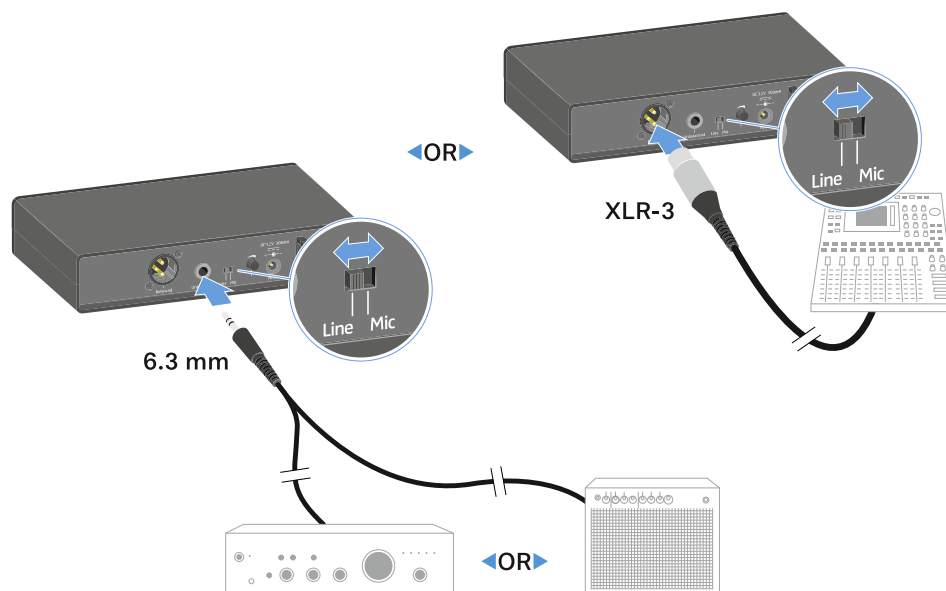

To connect an XLR cable:

- ▶ Plug the XLR cable into the **Balanced** socket on the EM-XSW 1.

To connect a jack cable:

- ▶ Plug the jack cable into the **Unbalanced** socket on the EM-XSW 1.
- ▶ Set the **Line/Mic** switch to the desired position.
 - **Line**: when using instruments or other line sources with the SK-XSW bodypack transmitter
 - **Mic**: when using the SKM 825/835-XSW handheld transmitter or a microphone with the SK-XSW bodypack transmitter



Switching the receiver on and off

To switch the receiver on:

- ▶ Short-press the **ON/OFF** button.



- ✓ The receiver switches on.

To switch the receiver to standby mode:

- ▶ Hold down the **ON/OFF** button until the display switches off.

To switch the receiver off completely:

- ▶ Disconnect the receiver from the power supply system by unplugging the power supply unit from the wall socket.



Information on the receiver's display

Status information such as frequency, reception quality, battery status and audio level is shown on the display.

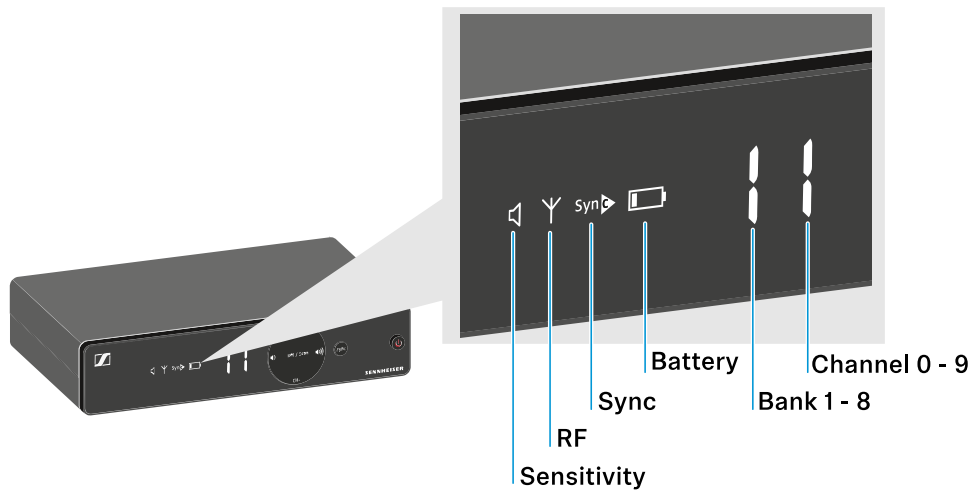

Sensitivity:

Indicates the sensitivity of the connected transmitter

- SKM: [Setting the input sensitivity](#)
- SK: [Setting the input sensitivity](#)



RF:

If the antenna symbol is displayed, the radio link is active.

- [Establishing a radio link | Synchronizing the receiver and transmitter](#)



Sync: [Establishing a radio link | Synchronizing the receiver and transmitter](#)



Battery:

Battery status of the connected transmitter

- SKM: [Battery status](#)
- SK: [Battery status](#)



Bank / Channel:

Frequency bank and channel of the radio link

- [Setting options on the front of the device](#)



Setting options on the front of the device

Navigation buttons

Use the following buttons to navigate through the receiver's settings.

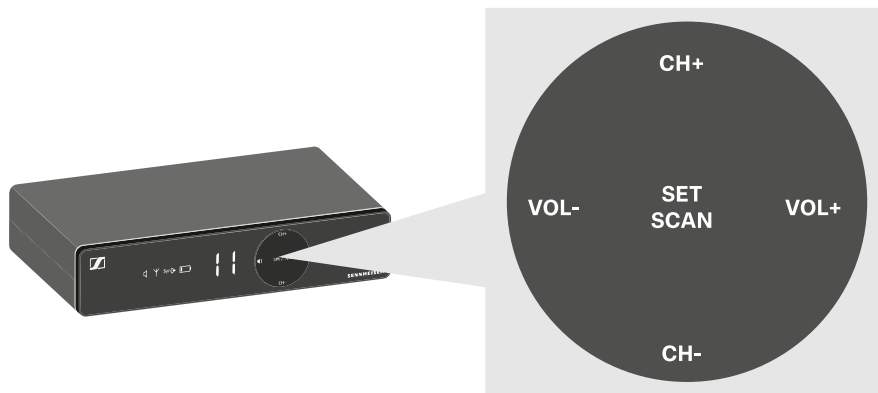

Setting the frequency automatically (AUTO SCAN)

- i** Performs an automatic frequency scan of your area. This enables you to easily find and assign free radio frequencies.
- ▶ Switch off all transmitters before you perform the scan. If transmitters are still switched on, they are detected as unavailable frequencies and the frequencies that are actually available cannot then be used.
- ▶ Press the **SET/SCAN** button for approx. 3 seconds.

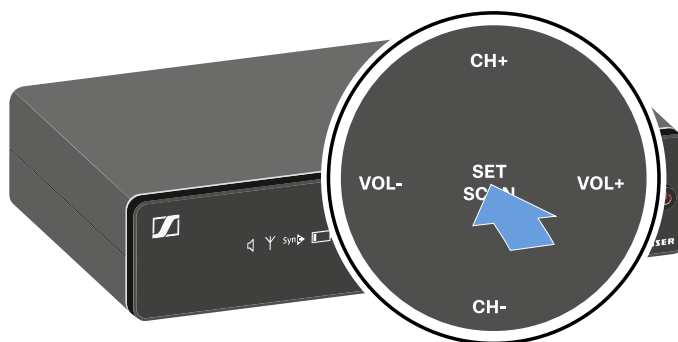

- ✓ The scan starts automatically. An open channel is then shown in the display (e.g. bank 2, channel 3).



- ▶ Press the **SET/SCAN** button to accept the displayed channel.

i If you have set a new frequency, you must still synchronize the receiver with the transmitter to establish the radio link (see [Establishing a radio link | Synchronizing the receiver and transmitter](#)).

Setting the frequency manually

- ▶ Press the **SET/SCAN** button.

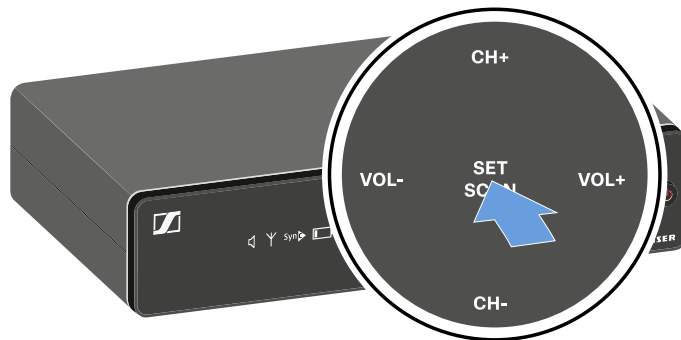

- ▶ Press the **CH+/CH-** buttons to select a frequency bank (1 to 8).

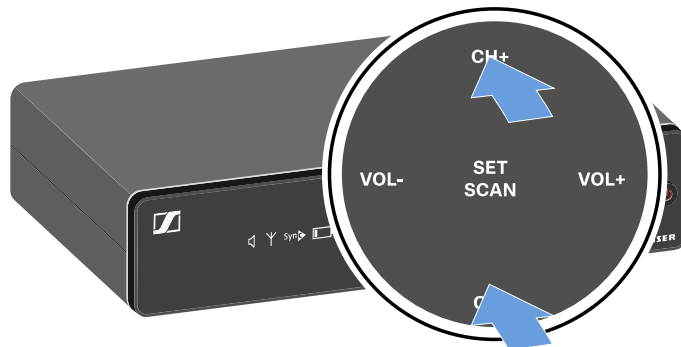

- ▶ Press the **SET/SCAN** button to accept the selected frequency bank.



- ▶ Press the **CH+/CH-** buttons to select a channel (0 to 9) in the selected frequency bank.
 - ✓ The selected bank and channel are shown in the display (e.g. bank 2, channel 3).



- ▶ Press the **SET/SCAN** button to accept the selected channel.

i If you have set a new frequency, you must still synchronize the receiver with the transmitter to establish the radio link (see [Establishing a radio link | Synchronizing the receiver and transmitter](#)).

Adjusting the volume of the audio outputs

i Use the **VOL+/VOL-** buttons to set the level of the audio signal coming from the receiver's audio outputs (**Balanced/Unbalanced**). This audio signal can be output to a mixing console or an amplifier, for example.

- ▶ Press the **VOL+/VOL-** buttons to adjust the volume.

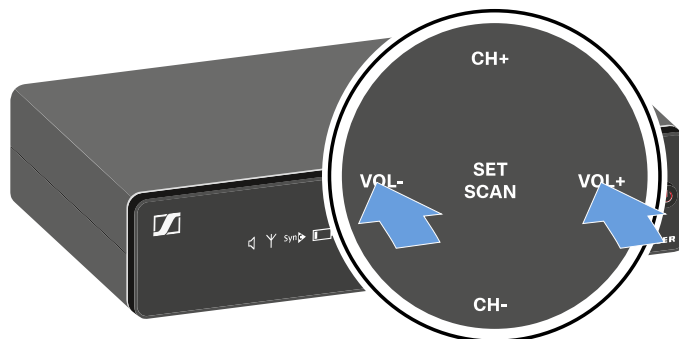

- ▶ Make sure that the signal in the next device in the signal chain (e.g. mixing console, power amplifier, guitar amplifier, etc.) is not overdriven.



Setting options on the rear of the device

Selecting the signal type (Mic/Line)

- ▶ Set the Line/Mic switch to the desired position.



- **Line:** when using instruments or other line sources with the SK-XSW bodypack transmitter
- **Mic:** when using the SKM-XSW handheld transmitter or a microphone with the SK-XSW bodypack transmitter



Setting the squelch

- i** The squelch function can be used to suppress disturbing noise during transmission, such as hiss. If the signal level is below the squelch threshold, the signal is muted.
If the squelch threshold is set very high, this will shorten the radio range.

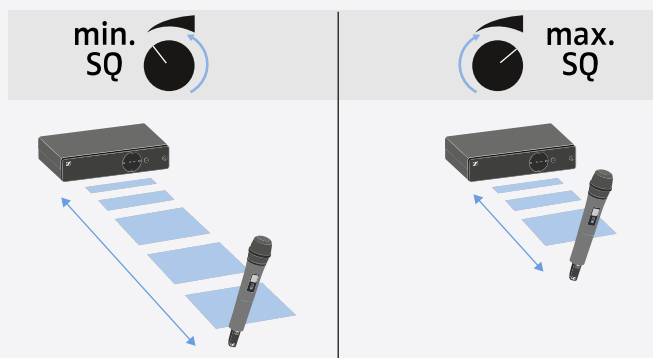
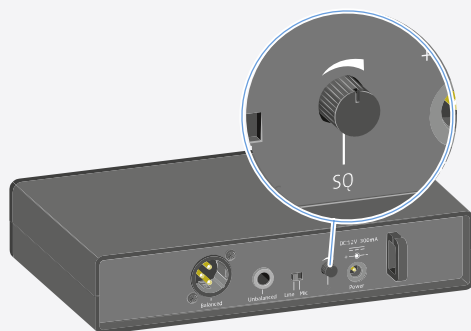

- ▶ Turn the control knob to the left or right to adjust the squelch.



Configuring a multi-channel system

Please note when creating multi-channel systems: Only the factory-preset transmission frequencies within one frequency bank are intermodulation-free.

- ▶ Set the same channel bank for all receivers.
- ▶ Assign one channel from this channel bank to each receiver.

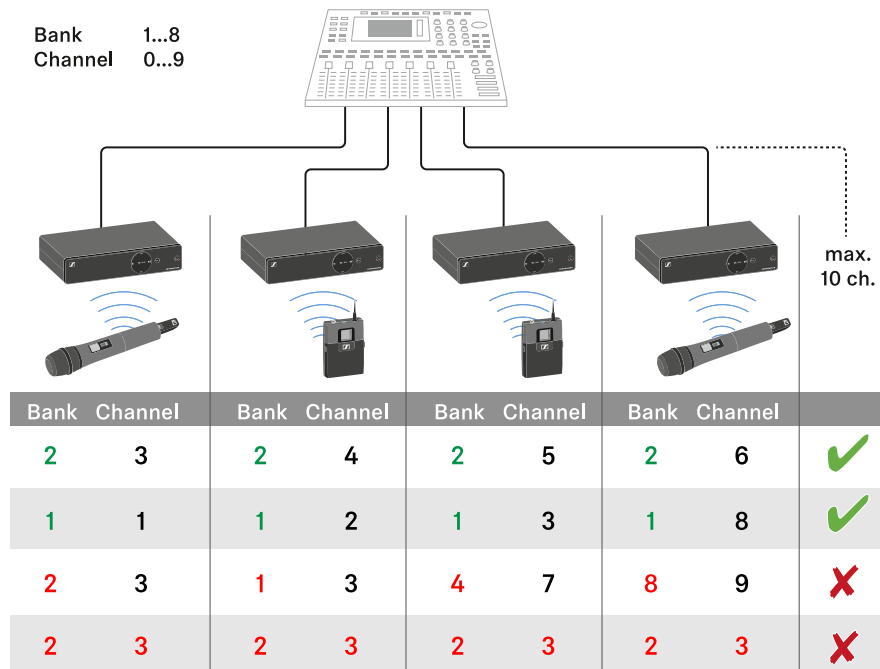

i We recommend using the **AUTO SCAN** function, as this is the most reliable way to identify free frequencies (see [Setting the frequency automatically \(AUTO SCAN\)](#)).
If you know free frequencies in your area, you can also set the frequency manually (see [Setting the frequency manually](#)).



EM-XSW 1 DUAL rack receiver

The EM-XSW 1 DUAL two-channel receiver is essentially two individual EM-XSW 1 receivers in one housing.

Each of the two receiver channels has separate connectors and setting options.

Product overview

Front

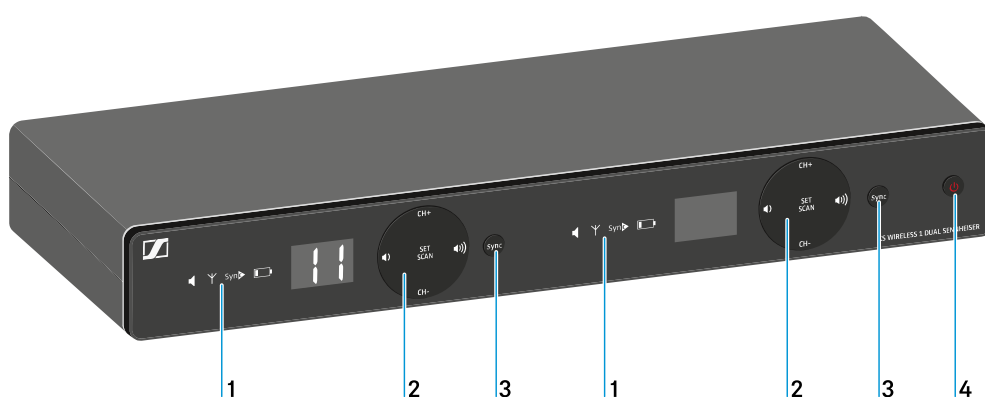

1 Display for status information

- for each of the two channels
- see [Information on the receiver's display](#)

2 Control buttons for selecting channels and adjusting volume

- for each of the two channels
- see [Setting options on the front of the device](#)

3 **SYNC** button for synchronizing the transmitter and receiver

- for each of the two channels
- see [Establishing a radio link | Synchronizing the receiver and transmitter](#)

4 **ON/OFF** button for switching the device on and off

- see [Switching the receiver on and off](#)



Back

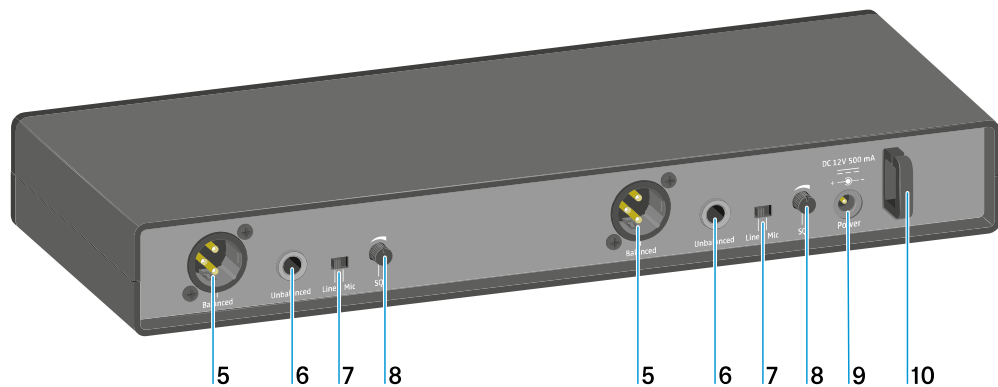

5 XLR-3 socket for **Balanced** audio output

- for each of the two channels
- see [Outputting audio signals](#)

6 6.3 mm jack socket for **Unbalanced** audio output

- for each of the two channels
- see [Outputting audio signals](#)

7 **Line/Mic** switch for selecting the signal type

- for each of the two channels
- see [Setting options on the rear of the device](#)
- see [Outputting audio signals](#)

8 SQ control knob for adjusting the squelch value

- for each of the two channels
- see [Setting options on the rear of the device](#)

9 Power connection socket for the power supply unit

- see [Connecting/disconnecting the receiver to/from the power supply system](#)

10 Strain relief for the connection cable of the power supply unit

- see [Connecting/disconnecting the receiver to/from the power supply system](#)



Connecting/disconnecting the receiver to/from the power supply system

Only use the supplied power supply unit. It is designed for your receiver and ensures safe operation.

To connect the receiver to the power supply system:

- ▶ Pass the cable of the power supply unit through the strain relief.
- ▶ Insert the plug of the power supply unit into the Power socket on the receiver.
- ▶ Slide the supplied country adapter onto the power supply unit.
- ▶ Plug the power supply unit into the wall socket.

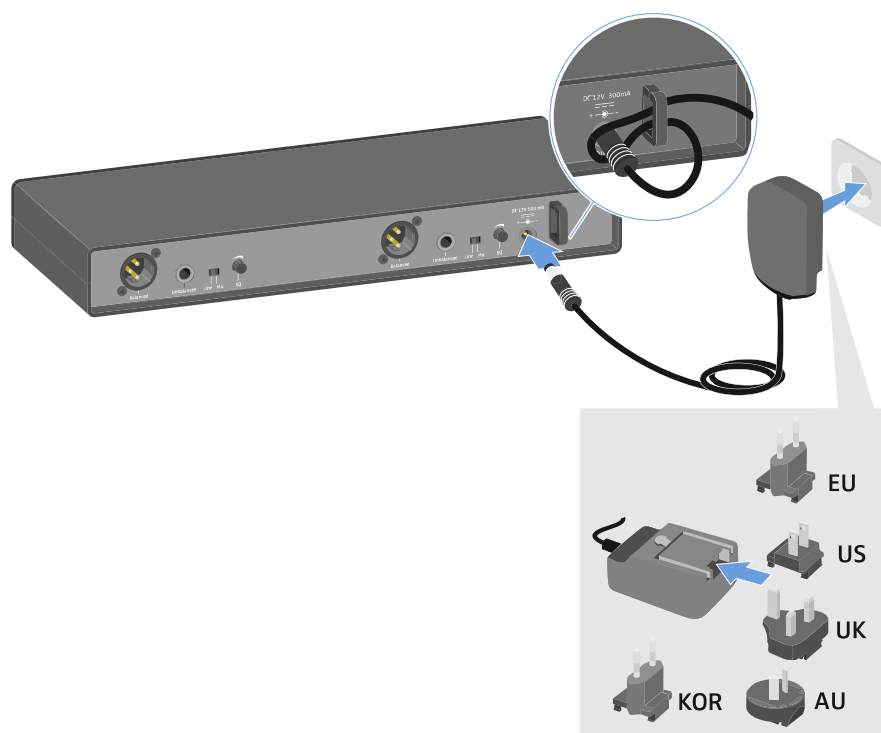

To completely disconnect the receiver from the power supply system:

- ▶ Unplug the power supply unit from the wall socket.
- ▶ Unplug the power supply unit from the Power socket on the receiver.



Outputting audio signals

Each of the two channels on the EM-XSW1 DUAL has both a balanced XLR-3M output socket and an unbalanced 6.3 mm (1/4") jack output socket.

- ▶ Always use only one of the two output sockets for each channel.

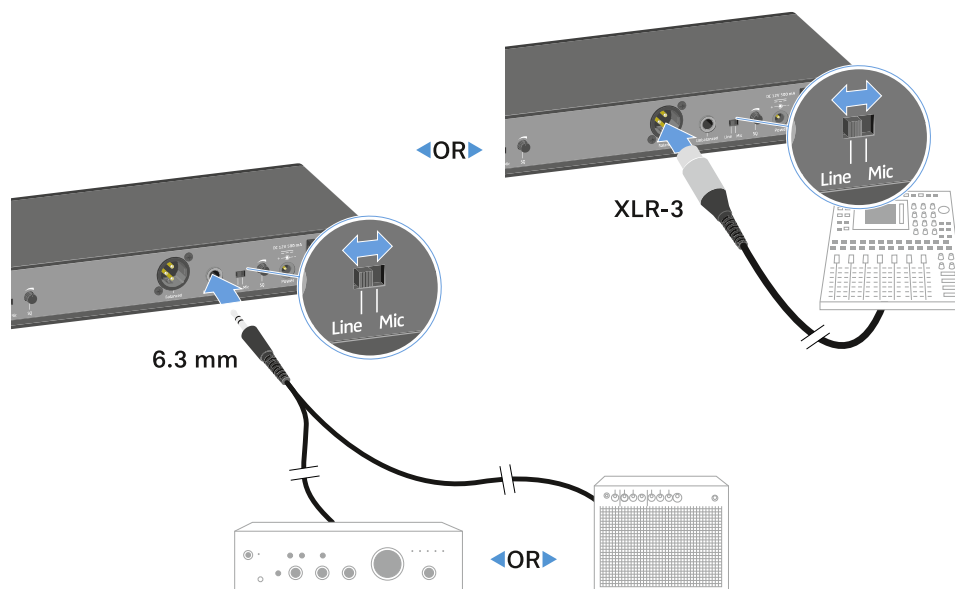

To connect an XLR cable:

- ▶ Plug the XLR cable into the **Balanced** socket for the respective channel on the EM-XSW 1 DUAL.

To connect a jack cable:

- ▶ Plug the jack cable into the **Unbalanced** socket for the respective channel on the EM-XSW 1 DUAL.
- ▶ Set the Line/Mic switch to the desired position for each of the two channels.
 - **Line:** when using instruments or other line sources with the SK-XSW bodypack transmitter
 - **Mic:** when using the SKM 825/835-XSW handheld transmitter or a microphone with the SK-XSW bodypack transmitter



Switching the receiver on and off

To switch the receiver on:

- ▶ Short-press the **ON/OFF** button.



- ✔ The receiver switches on.

To switch the receiver to standby mode:

- ▶ Hold down the **ON/OFF** button until the display switches off.

To switch the receiver off completely:

- ▶ Disconnect the receiver from the power supply system by unplugging the power supply unit from the wall socket.



Information on the receiver's display

Status information such as frequency, reception quality, battery status and audio level is shown on the display for each of the two channels.

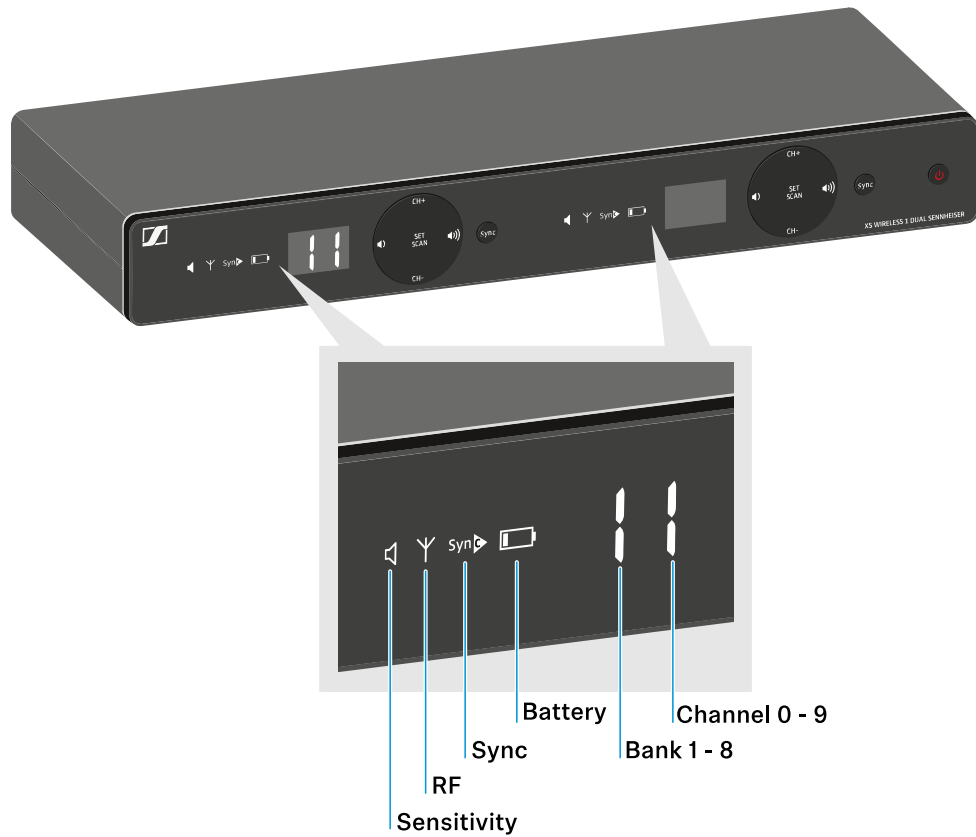

Sensitivity:

Indicates the sensitivity of the connected transmitter

- SKM: [Setting the input sensitivity](#)
- SK: [Setting the input sensitivity](#)



RF:

If the antenna symbol is displayed, the radio link is active.

- [Establishing a radio link | Synchronizing the receiver and transmitter](#)



Sync: [Establishing a radio link | Synchronizing the receiver and transmitter](#)



Battery:

Battery status of the connected transmitter

- SKM: [Battery status](#)
- SK: [Battery status](#)



Bank / Channel:

Frequency bank and channel of the radio link

- [Setting options on the front of the device](#)
-



Setting options on the front of the device

Navigation buttons

Use the following buttons to navigate through the receiver's settings.



Setting the frequency automatically (AUTO SCAN)

- i** Performs an automatic frequency scan of your area. This enables you to easily find and assign free radio frequencies.
- ▶ Switch off all transmitters before you perform the scan. If transmitters are still switched on, they are detected as unavailable frequencies and the frequencies that are actually available cannot then be used.
- ▶ Press the **SET/SCAN** button for approx. 3 seconds.

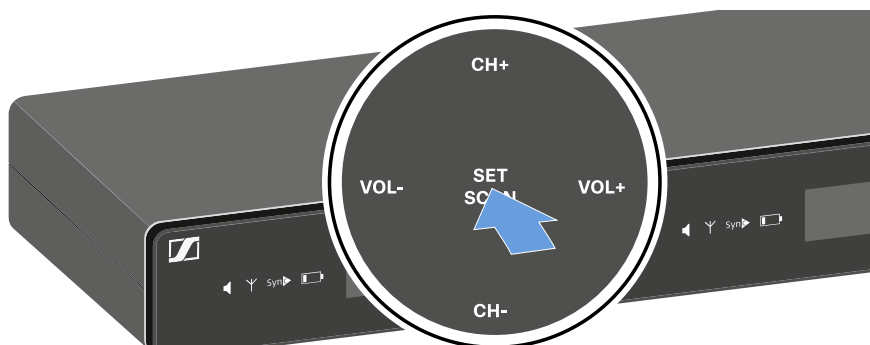

- ✓ The scan starts automatically. An open channel is then shown in the display (e.g. bank 2, channel 3).



- ▶ Press the **SET/SCAN** button to accept the displayed channel.

i If you have set a new frequency, you must still synchronize the receiver with the transmitter to establish the radio link (see [Establishing a radio link | Synchronizing the receiver and transmitter](#)).

Setting the frequency manually

- ▶ Press the **SET/SCAN** button.

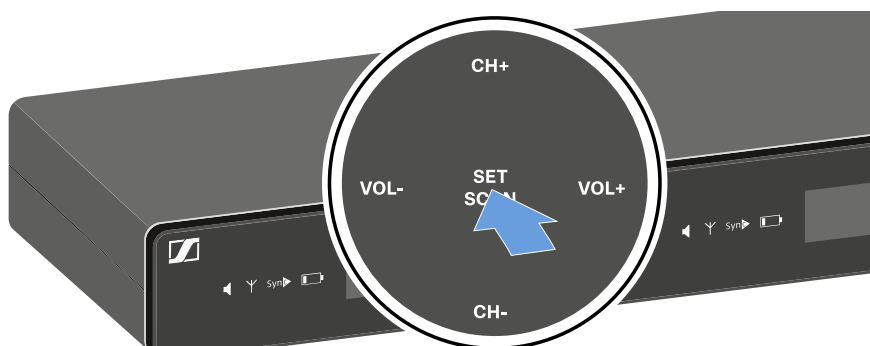

- ▶ Press the **CH+/CH-** buttons to select a frequency bank (1 to 8).

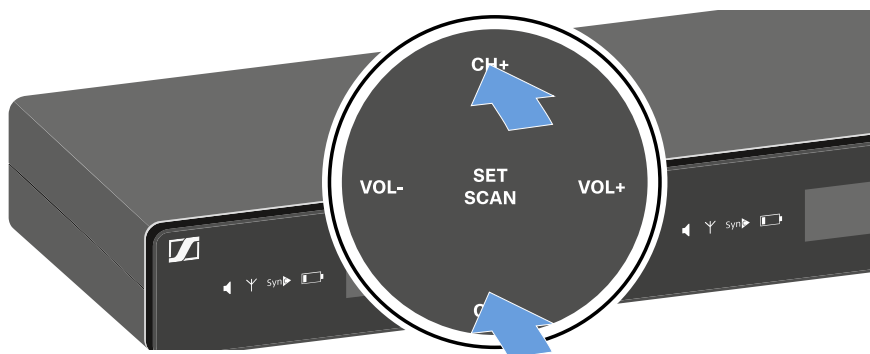

- ▶ Press the **SET/SCAN** button to accept the selected frequency bank.
- ▶ Press the **CH+/CH-** buttons to select a channel (0 to 9) in the selected frequency bank.
- ✔ The selected bank and channel are shown in the display (e.g. bank 2, channel 3).



- ▶ Press the **SET/SCAN** button to accept the selected channel.

i If you have set a new frequency, you must still synchronize the receiver with the transmitter to establish the radio link (see [Establishing a radio link | Synchronizing the receiver and transmitter](#)).



Adjusting the volume of the audio outputs

- i** Use the **VOL+/VOL-** buttons to set the level of the audio signal coming from the receiver's audio outputs (**Balanced/Unbalanced**). This audio signal can be output to a mixing console or an amplifier, for example.

- ▶ Press the **VOL+/VOL-** buttons to adjust the volume.

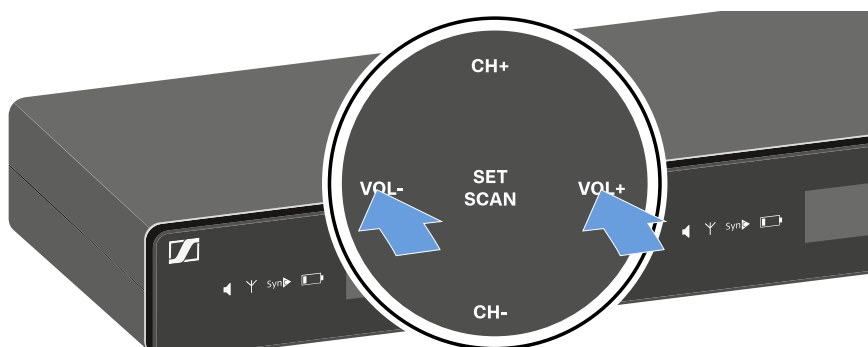

- ▶ Make sure that the signal in the next device in the signal chain (e.g. mixing console, power amplifier, guitar amplifier, etc.) is not overdriven.



Setting options on the rear of the device

Selecting the signal type (Mic/Line)

- ▶ Set the **Line/Mic** switch to the desired position for each of the two channels.

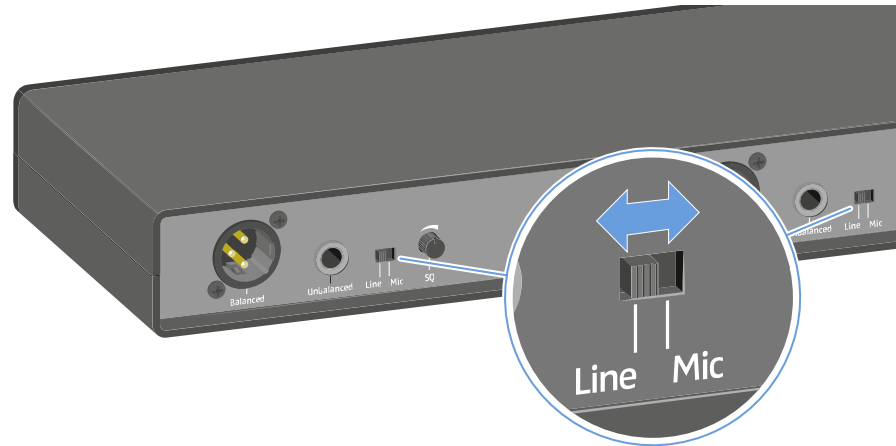

- **Line:** when using instruments or other line sources with the SK-XSW bodypack transmitter
- **Mic:** when using the SKM-XSW handheld transmitter or a microphone with the SK-XSW bodypack transmitter



Setting the squelch

- i** The squelch function can be used to suppress disturbing noise during transmission, such as hiss. If the signal level is below the squelch threshold, the signal is muted.
If the squelch threshold is set very high, this will shorten the radio range.

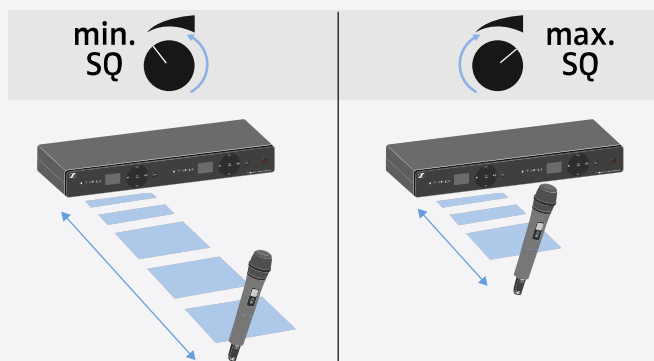
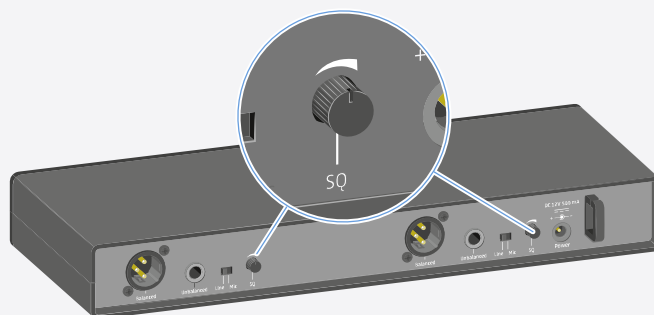

- ▶ Turn the control knob to the left or right to adjust the squelch.



Configuring a multi-channel system

Please note when creating multi-channel systems: Only the factory-preset transmission frequencies within one frequency bank are intermodulation-free.

- ▶ Set the same channel bank for all receivers.
- ▶ Assign one channel from this channel bank to each receiver.

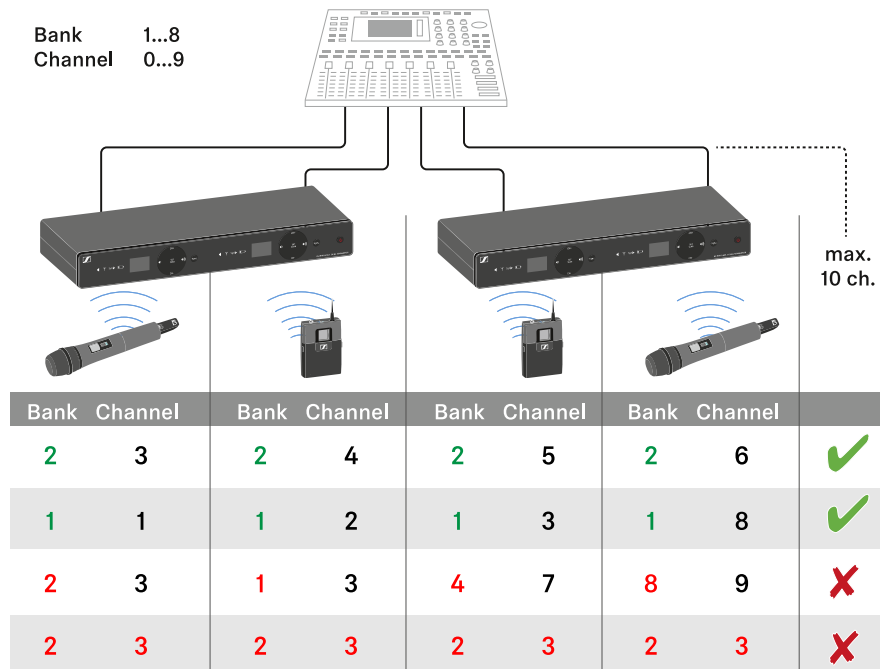

i We recommend using the **AUTO SCAN** function, as this is the most reliable way to identify free frequencies (see [Setting the frequency automatically \(AUTO SCAN\)](#)).
If you know free frequencies in your area, you can also set the frequency manually (see [Setting the frequency manually](#)).



EM-XSW 2 rack receiver

Product overview

Front

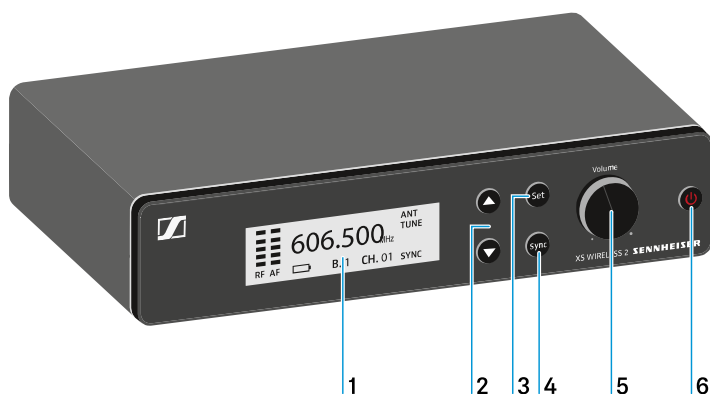

1 Display for status information

- see [Information on the receiver's display](#)

2 **UP/DOWN** menu buttons for navigating the operating menu

- see [Setting options on the front of the device](#)

3 **SET** menu button for navigating the operating menu

- see [Setting options on the front of the device](#)

4 **SYNC** button for synchronizing the transmitter and receiver

- see [Establishing a radio link | Synchronizing the receiver and transmitter](#)

5 Control knob for adjusting the volume

- see [Adjusting the volume of the audio outputs](#)

6 **ON/OFF** button for switching the device on and off and canceling an action in the menu

- see [Switching the receiver on and off](#)
- see [Setting options on the front of the device](#)



Back

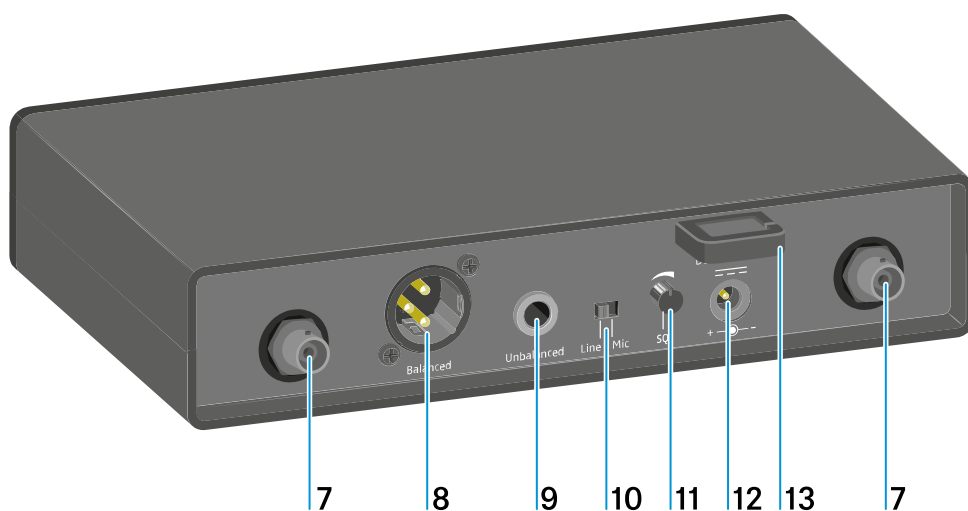

7 BNC sockets, antenna inputs

- see [Connecting antennas](#)

8 XLR-3 socket for **Balanced** audio output

- see [Outputting audio signals](#)

9 6.3 mm jack socket for **Unbalanced** audio output

- see [Outputting audio signals](#)

10 **Line/Mic** switch for selecting the signal type

- see [Setting options on the rear of the device](#)
- see [Outputting audio signals](#)

11 SQ control knob for adjusting the squelch value

- see [Setting options on the rear of the device](#)

12 Power connection socket for the power supply unit

- see [Connecting/disconnecting the receiver to/from the power supply system](#)



13 Strain relief for the connection cable of the power supply unit

- see [Connecting/disconnecting the receiver to/from the power supply system](#)



Connecting/disconnecting the receiver to/from the power supply system

Only use the supplied power supply unit. It is designed for your receiver and ensures safe operation.

To connect the receiver to the power supply system:

- ▶ Pass the cable of the power supply unit through the strain relief.
- ▶ Insert the plug of the power supply unit into the Power socket on the receiver.
- ▶ Slide the supplied country adapter onto the power supply unit.
- ▶ Plug the power supply unit into the wall socket.

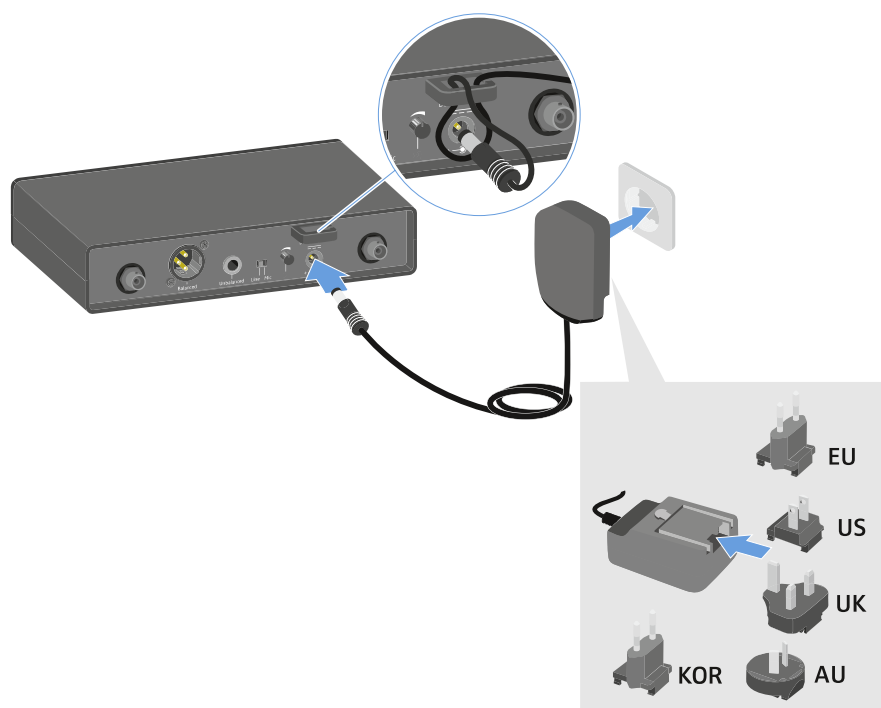

To completely disconnect the receiver from the power supply system:

- ▶ Unplug the power supply unit from the wall socket.
- ▶ Unplug the power supply unit from the Power socket on the receiver.



Connecting antennas

To connect the supplied rod antennas:

- ▶ Connect the antennas to the two antenna inputs on the receiver as shown in the figure.
- ▶ Slightly angle the antennas to the left and right as shown in the figure.

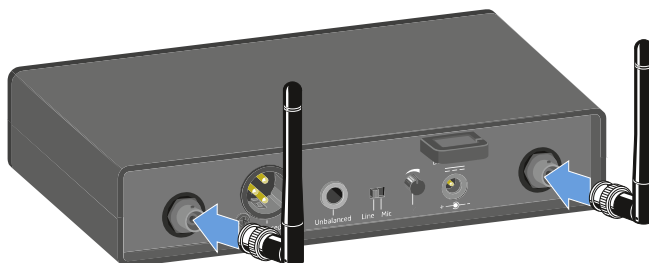



Outputting audio signals

The EM-XSW 2 has a balanced XLR-3M output socket and an unbalanced 6.3 mm jack output socket.

- ▶ Always use only one of the two output sockets.

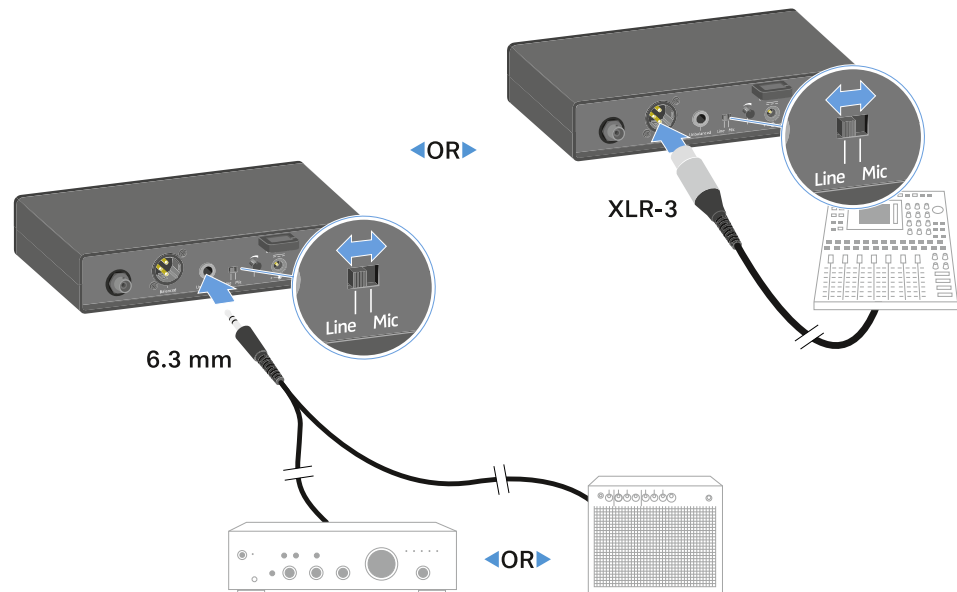

To connect an XLR cable:

- ▶ Plug the XLR cable into the **Balanced** socket on the EM-XSW 2.

To connect a jack cable:

- ▶ Plug the jack cable into the **Unbalanced** socket on the EM-XSW 2.
- ▶ Set the **Line/Mic** switch to the desired position.
 - **Line**: when using instruments or other line sources with the SK-XSW bodypack transmitter
 - **Mic**: when using the SKM 835/865-XSW handheld transmitter or a microphone with the SK-XSW bodypack transmitter



Installing receivers in a rack

NOTICE



Rack mounting poses risks

When installing the device in a closed 19" rack or multi-rack assembly, please consider that, during operation, the ambient temperature, the mechanical load and the electrical potentials will be different from those of devices which are not mounted into a rack.

- ▶ Make sure that the ambient temperature within the rack does not exceed the permissible temperature limit stated in the specifications. See [Specifications](#).
- ▶ Ensure sufficient ventilation; if necessary, provide additional ventilation.
- ▶ Make sure that the mechanical load of the rack is even.
- ▶ When connecting to the power supply system, observe the information indicated on the type plate. Avoid overloading the circuits. If necessary, provide overcurrent protection.
- ▶ When mounting in a rack, please note that intrinsically harmless leakage currents of the individual power supply units may accumulate, thereby exceeding the permissible limit value. As a remedy, ground the rack via an additional ground connection.

To mount the receiver in a rack, you will need the GA 1-XSW 2 rack mount kit (see [Accessories](#)).

Mounting a single receiver in a rack

- ▶ Connect the mounting brackets to the sides of the receiver as shown in the figure.

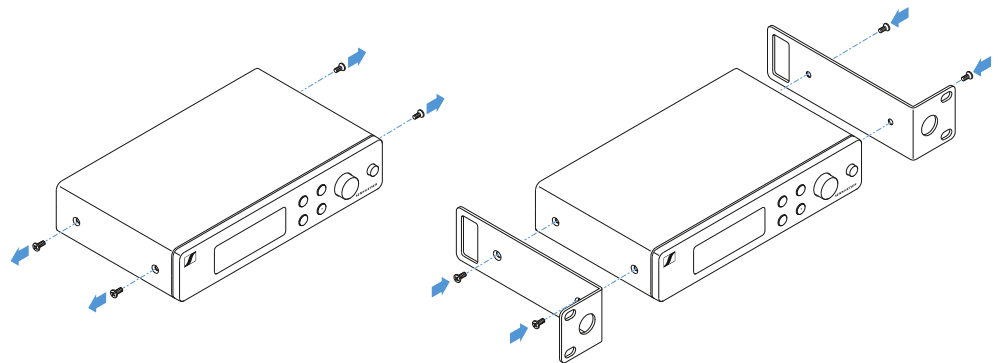

- ▶ Attach the front panel as shown in the figure.
- ▶ If desired, attach the antennas to the front panel as shown in the figure.



This requires the optional GA 2-XSW 2 antenna front mount kit (see [Accessories](#)).

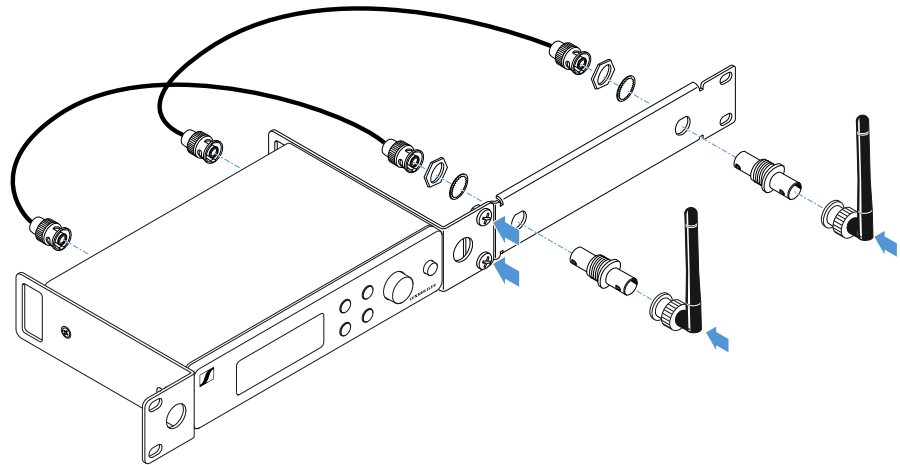

Mounting two receivers side by side in a rack

- ▶ Place both receivers upside down and side by side on an even surface.
- ▶ Tighten the jointing plate as shown in the figure.
- ▶ Attach the mounting brackets as shown in the figure.

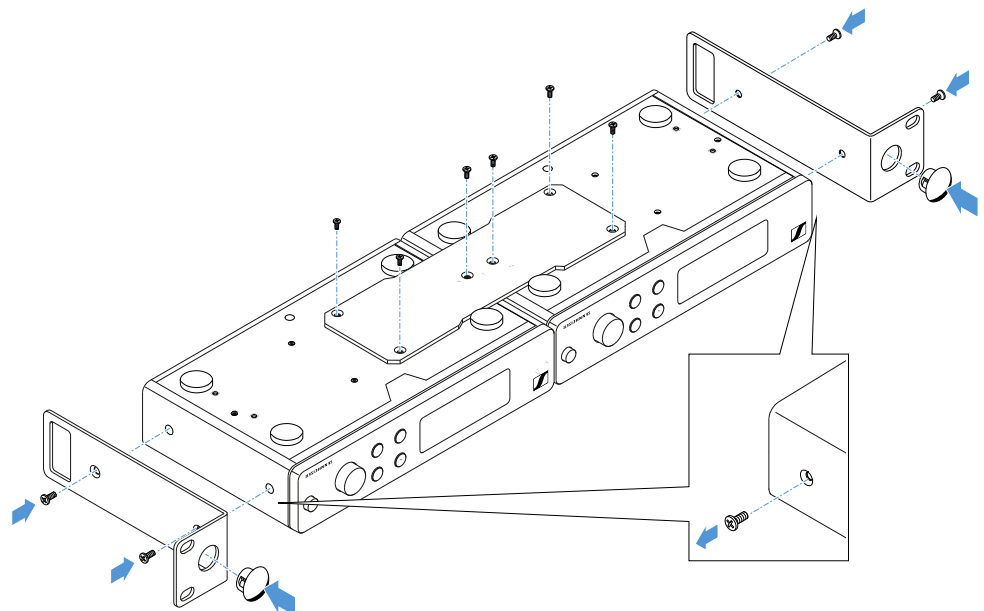



Switching the receiver on and off

To switch the receiver on:

- ▶ Short-press the ON/OFF button.

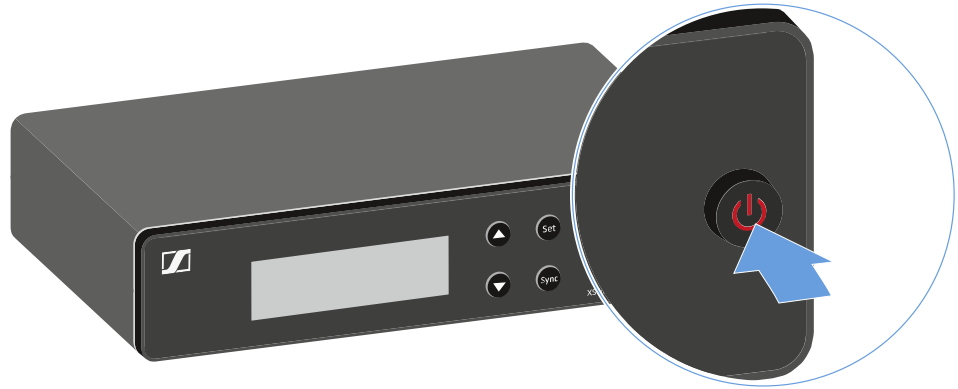

- ✓ The receiver switches on.

To switch the receiver to standby mode:

- ▶ Hold down the **ON/OFF** button until the display switches off.

To switch the receiver off completely:

- ▶ Disconnect the receiver from the power supply system by unplugging the power supply unit from the wall socket.



Information on the receiver's display

Status information such as frequency, reception quality, battery status and audio level is shown on the display.

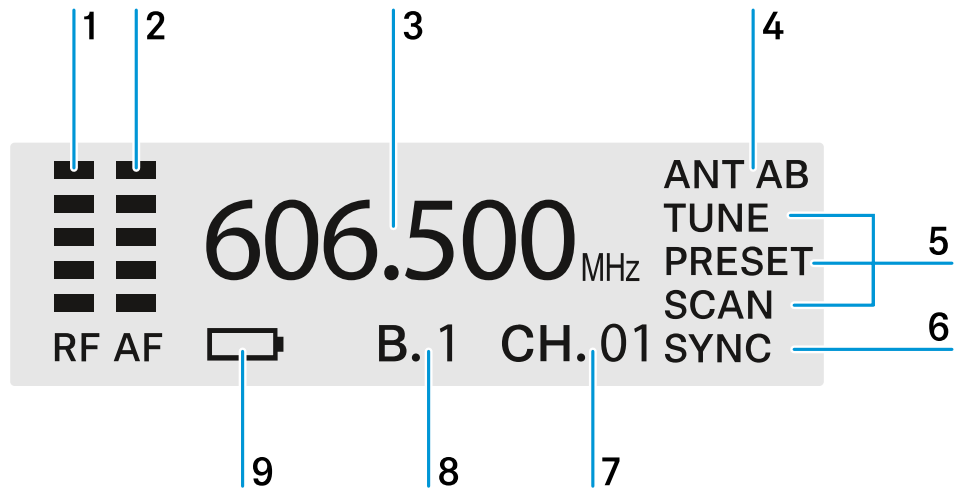

1 Radio frequency level

- [Establishing a radio link | Synchronizing the receiver and transmitter](#)

2 Transmitter audio level

- XSW-SKM: [Setting the input sensitivity](#)
- XSW-SK: [Setting the input sensitivity](#)

3 Frequency

- [SCAN menu item](#)
- [PRESET menu item](#)
- [TUNE menu item](#)

4 Antenna diversity:

- Shows which of the two antennas is currently being used for the radio link (ANT A or ANT B)

5 Menu

- [Setting options on the front of the device](#)

6 Sync

- [Establishing a radio link | Synchronizing the receiver and transmitter](#)



7 Channel

- [SCAN menu item](#)
- [PRESET menu item](#)
- [TUNE menu item](#)

8 Bank

- [SCAN menu item](#)
- [PRESET menu item](#)
- [TUNE menu item](#)

9 Transmitter battery

- XSW-SKM: [Battery status](#)
- XSW-SK: [Battery status](#)



Setting options on the front of the device

Navigation buttons

Use the following buttons to navigate through the receiver's settings.

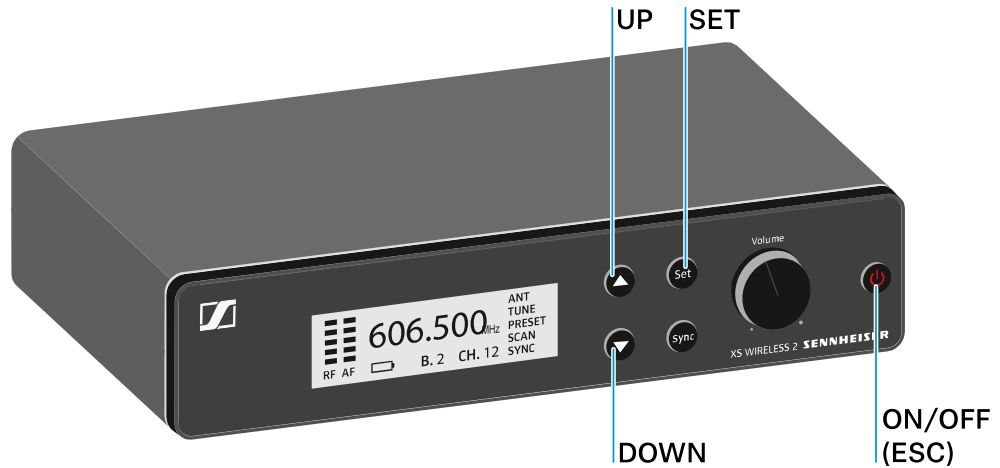

Press the **UP** or **DOWN** button

- Changes to the previous or next menu item
- Changes the setting of a menu item

Press the **SET** button

- Save settings in a menu item

Press the **ON/OFF (ESC)** button

- Cancel input

SCAN menu item

Under the **SCAN** menu item, you can perform an automatic frequency scan of your area.

This enables you to easily find and assign free radio frequencies.

- i** Switch off all transmitters before you perform the scan. If transmitters are still switched on, they are detected as unavailable frequencies and the frequencies that are actually available cannot then be used.



- ▶ Press the **UP** or **DOWN** button until the **SCAN** menu item appears in the display.

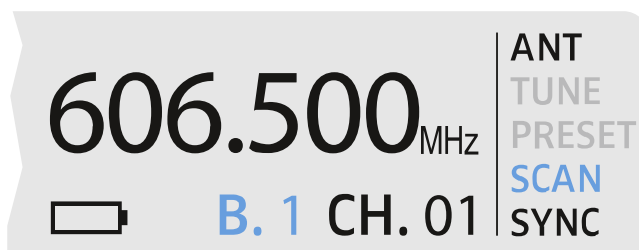

- ▶ Press the **SET** button to open the menu item.
- ▶ Press the **UP** or **DOWN** button to select a frequency bank.

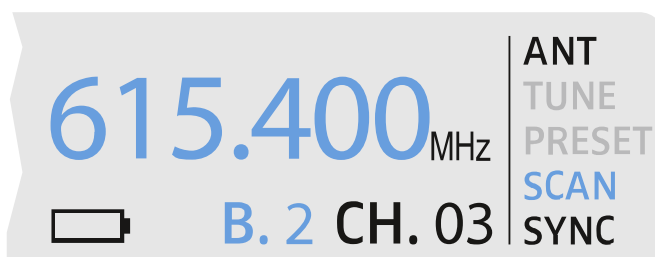

- ▶ Press the **SET** button to start the frequency scan in the selected bank.
 - ✓ The next free frequency is shown on the display.
- ▶ Press the **SET** button to accept the displayed frequency.
OR
- ▶ Press the **UP** or **DOWN** button to display the next free frequency.
OR
- ▶ Press the **ON/OFF (ESC)** button to cancel the scan.
 - ✓ The previous frequency remains unchanged.

i If you have set a new frequency, you must still synchronize the receiver with the transmitter to establish the radio link (see [Establishing a radio link | Synchronizing the receiver and transmitter](#)).



PRESET menu item

Under the PRESET menu item, you can set the radio frequency by selecting a preset channel.

i If you are not sure whether the selected frequency is free, we recommend performing a scan to detect all free frequencies: [SCAN menu item](#).

- ▶ Press the **UP** or **DOWN** button until the **PRESET** menu item appears in the display.
- ▶ Press the **SET** button to open the menu item.
- ▶ Press the **UP** or **DOWN** button to select a frequency bank.

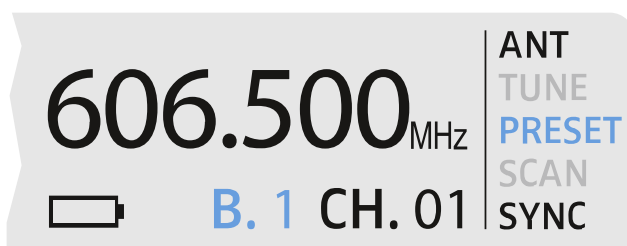

- ▶ Press the **SET** button to save the selected frequency bank.
- ▶ Press the **UP** or **DOWN** button to select a channel in the frequency bank.

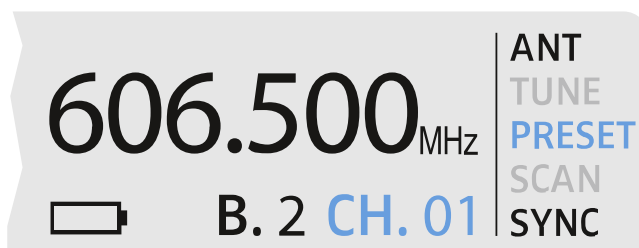

- ▶ Press the **SET** button to save the selected channel.

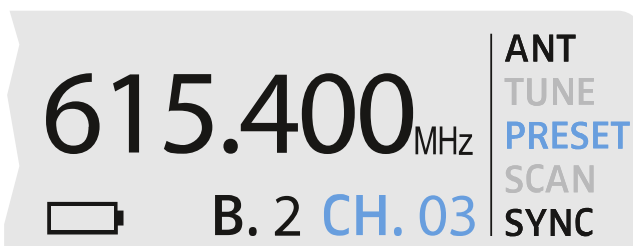



OR

- ▶ Press the **ON/OFF (ESC)** button to cancel the setting.
- ✔ The previous frequency remains unchanged.

i If you have set a new frequency, you must still synchronize the receiver with the transmitter to establish the radio link (see [Establishing a radio link | Synchronizing the receiver and transmitter](#)).



TUNE menu item

Under the TUNE menu item, you can manually set the radio frequency independently of the preset channels.

- i** If you are not sure whether the selected frequency is free, we recommend performing a scan to detect all free frequencies: [SCAN menu item](#).

- ▶ Press the **UP** or **DOWN** button until the **TUNE** menu item appears in the display.



- ▶ Press the **SET** button to open the menu item.
- ▶ Press the **UP** or **DOWN** button to set the frequency.

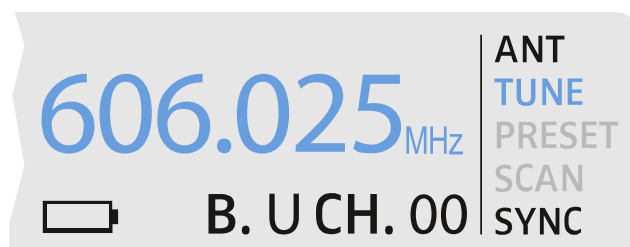

- ▶ Press the **SET** button to accept the displayed frequency.
OR
- ▶ Press the **ON/OFF (ESC)** button to cancel the setting.
 - ✔ The previous frequency remains unchanged.

- i** If you have set a new frequency, you must still synchronize the receiver with the transmitter to establish the radio link (see [Establishing a radio link | Synchronizing the receiver and transmitter](#)).



Adjusting the volume of the audio outputs

Use the **VOLUME** control knob to set the level of the audio signal coming from the receiver's audio outputs (**Balanced/Unbalanced**). This audio signal can be output to a mixing console or an amplifier, for example.

- ▶ Turn the **VOLUME** control knob to adjust the volume.



- ▶ Make sure that the signal in the next device in the signal chain (e.g. mixing console, power amplifier, guitar amplifier, etc.) is not overdriven.



Setting options on the rear of the device

Selecting the signal type (Mic/Line)

- ▶ Set the Line/Mic switch to the desired position.



- **Line:** when using instruments or other line sources with the SK-XSW bodypack transmitter
- **Mic:** when using the SKM-XSW handheld transmitter or a microphone with the SK-XSW bodypack transmitter



Setting the squelch

- i** The squelch function can be used to suppress disturbing noise during transmission, such as hiss. If the signal level is below the squelch threshold, the signal is muted.
If the squelch threshold is set very high, this will shorten the radio range.

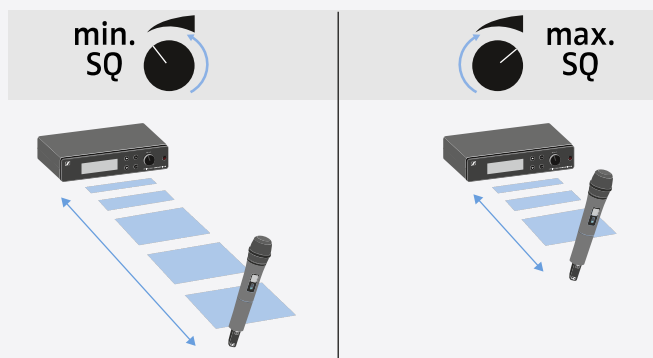
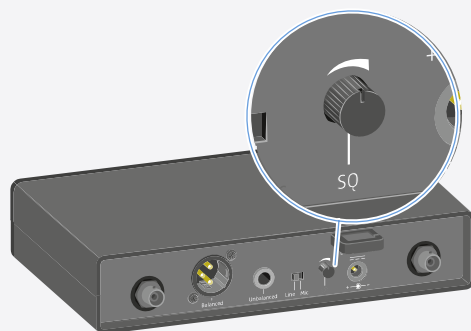

- ▶ Turn the control knob to the left or right to adjust the squelch.



Configuring a multi-channel system

Please note when creating multi-channel systems: Only the factory-preset transmission frequencies within one frequency bank are intermodulation-free.

- ▶ Set the same channel bank for all receivers.
- ▶ Assign one channel from this channel bank to each receiver.

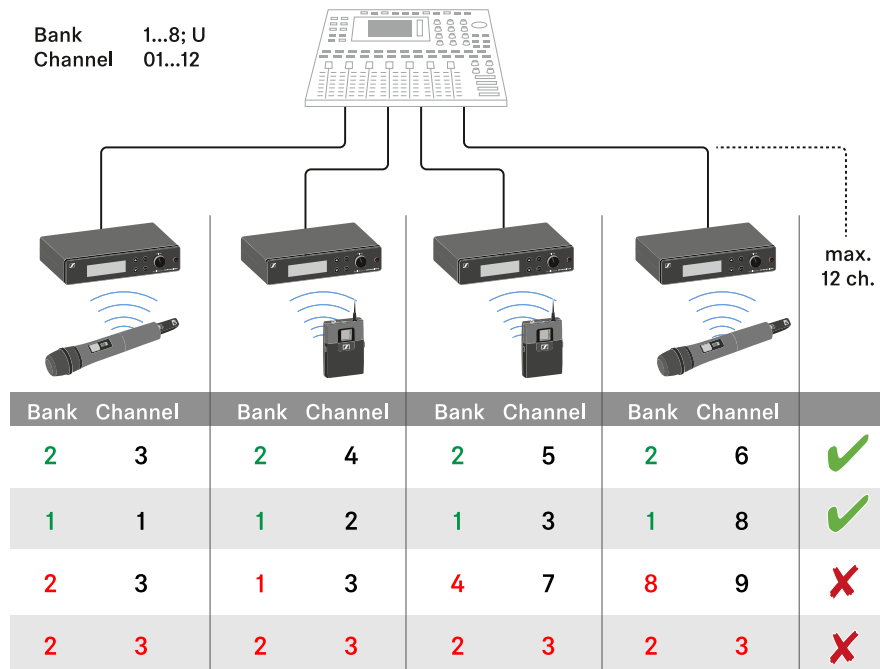

i We recommend using the **SCAN** function, as this is the most reliable way to identify free frequencies (see [SCAN menu item](#)).
If you know free frequencies in your area, you can also set the frequency manually (see [PRESET menu item](#) and [TUNE menu item](#)).



SKM XSW handheld transmitters

Product overview

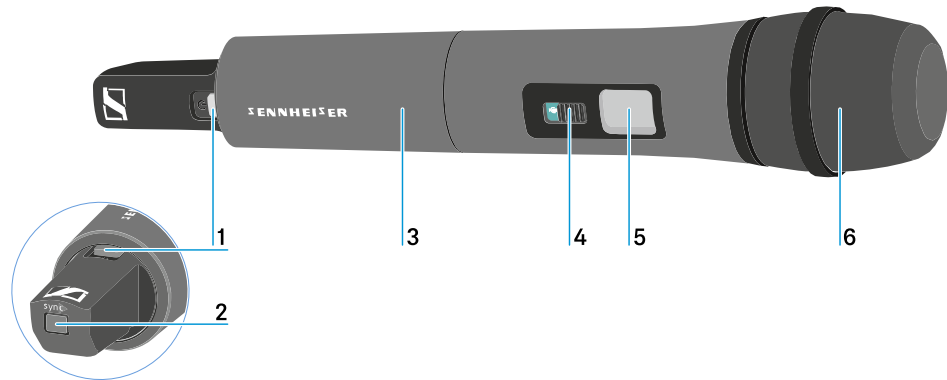

1 ON/OFF button with LED

- see [Switching the handheld transmitter on and off](#)
- Green: the radio link is established
- Flashing red/green: pairing active (see [Establishing a radio link | Synchronizing the receiver and transmitter](#))
- Flashing red: low battery (see [Inserting and removing the batteries](#))

2 SYNC button

- see [Establishing a radio link | Synchronizing the receiver and transmitter](#)

3 Unscrewable cover for accessing the battery compartment and **Sensitivity** switch

- see [Inserting and removing the batteries](#)
- see [Setting the input sensitivity](#)

4 Mute switch

- see [Muting the handheld transmitter](#)

5 Display panel

- see [Information on the handheld transmitter's display](#)

6 Microphone module

- with capsule 825, 835 or 865



Inserting and removing the batteries

You need two AA 1.5 V batteries to operate the handheld transmitter.

- ▶ Unscrew the microphone housing as shown in the figure and pull it downward.
- ▶ Insert the batteries as indicated in the battery compartment. Observe correct polarity.

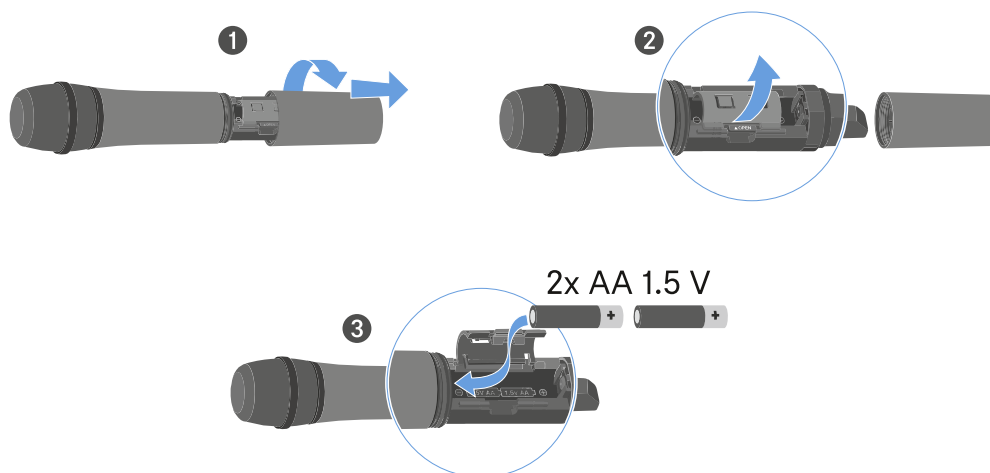

- ▶ Screw the microphone housing back on.

Battery status

Battery charge status in the display:

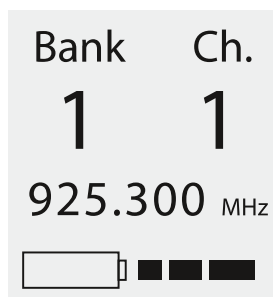

	~ 10 h
	~ 7 h
	~ 3 h
	Low Batt

Charge status is critical (LOW BATT):



SK-XSW



SKM-XSW

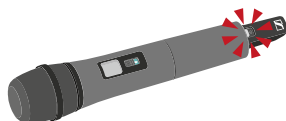

EM-XSW 1 /EM-XSW 1 DUAL



EM-XSW 2





Switching the handheld transmitter on and off

To switch the handheld transmitter on:

- ▶ Short-press the **ON/OFF** button.

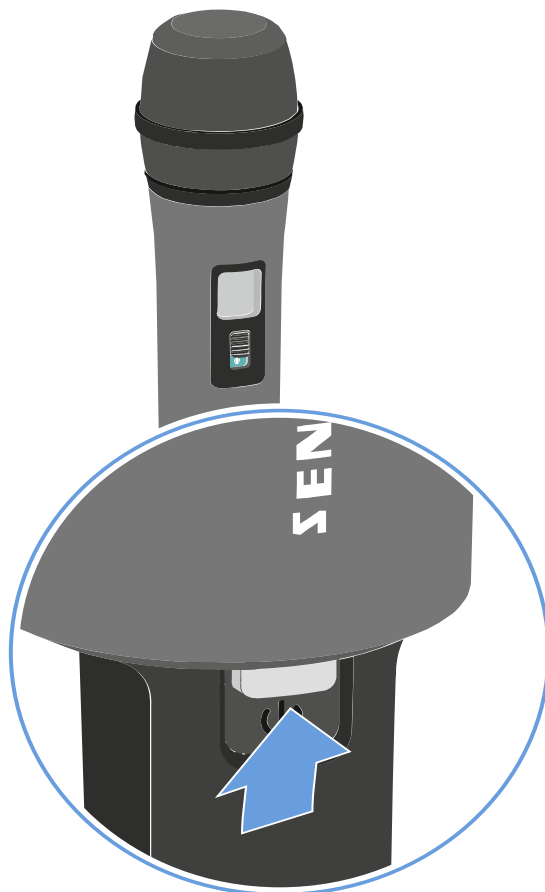

- ✔ The transmitter switches on. The **ON/OFF** button lights up.

To switch the handheld transmitter off:

- ▶ Hold down the **ON/OFF** button until the light in the **ON/OFF** button disappears.



Establishing a connection to the receiver

To establish a radio link between the transmitter and the receiver, the devices must be synchronized.

See [Establishing a radio link | Synchronizing the receiver and transmitter](#).

- i** Conditions and restrictions for using frequencies
There may be special conditions and restrictions for using frequencies in your country.
Before putting the product into operation, find the information for your country at the following address: [sennheiser.com/sifa](https://www.sennheiser.com/sifa).



Information on the handheld transmitter's display

You can view the following information on the transmitter display.

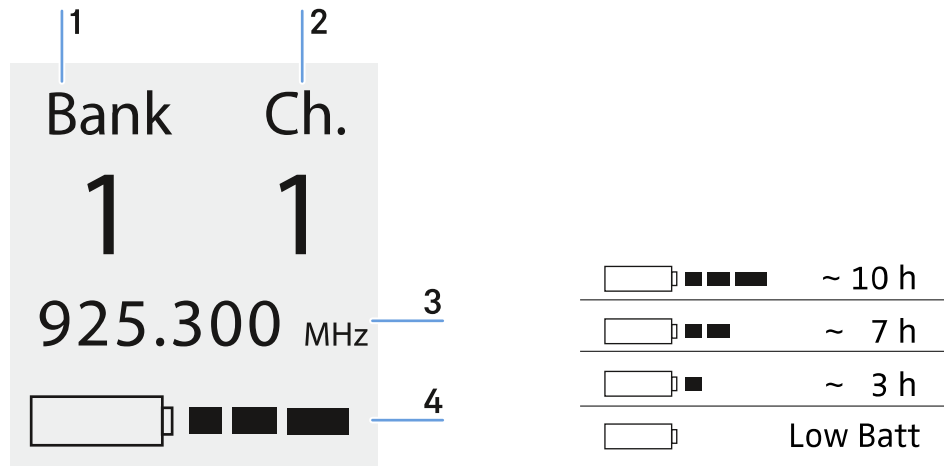

1 Frequency bank

- EM-XSW 1 [Setting the frequency automatically \(AUTO SCAN\)](#) | [Setting the frequency manually](#)
- EM-XSW 1 Dual [Setting the frequency manually](#) | [Setting the frequency automatically \(AUTO SCAN\)](#)
- EM-XSW 2 [SCAN menu item](#) | [PRESET menu item](#) | [TUNE menu item](#)

2 Channel

- EM-XSW 1 [Setting the frequency automatically \(AUTO SCAN\)](#) | [Setting the frequency manually](#)
- EM-XSW 1 Dual [Setting the frequency manually](#) | [Setting the frequency automatically \(AUTO SCAN\)](#)
- EM-XSW 2 [SCAN menu item](#) | [PRESET menu item](#) | [TUNE menu item](#)

3 Frequency

- EM-XSW 1 [Setting the frequency automatically \(AUTO SCAN\)](#) | [Setting the frequency manually](#)
- EM-XSW 1 Dual [Setting the frequency manually](#) | [Setting the frequency automatically \(AUTO SCAN\)](#)
- EM-XSW 2 [SCAN menu item](#) | [PRESET menu item](#) | [TUNE menu item](#)

4 Battery

- SKM XSW [Inserting and removing the batteries](#)
- SK-XSW [Inserting and removing the batteries](#)



Setting the input sensitivity

Use the **Sensitivity** switch to adjust the level of the audio signal sent to the receiver.

- ▶ Unscrew the microphone housing and pull it downward.
- ▶ Adjust the input sensitivity using the **Sensitivity** switch.
- ▶ Pay attention to the level indicator on the receiver display.

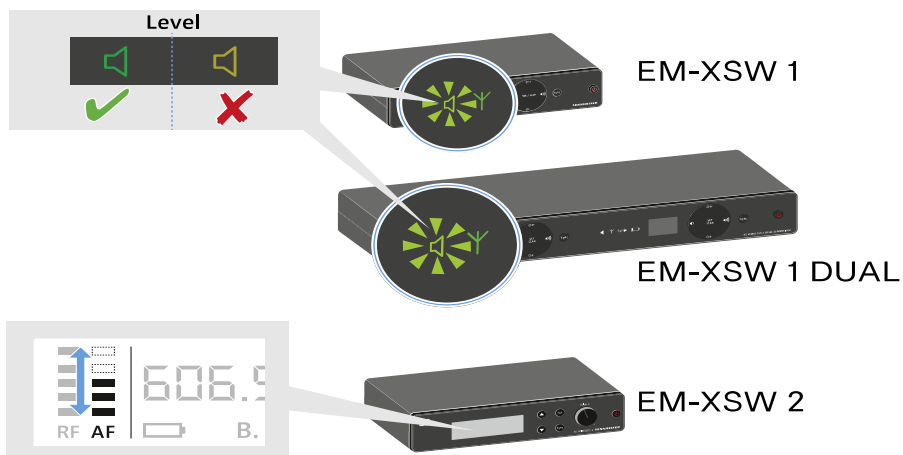



Muting the handheld transmitter

You can mute the audio signal using the mute switch.

- ▶ Slide the mute switch to the desired position to mute or activate the audio signal.

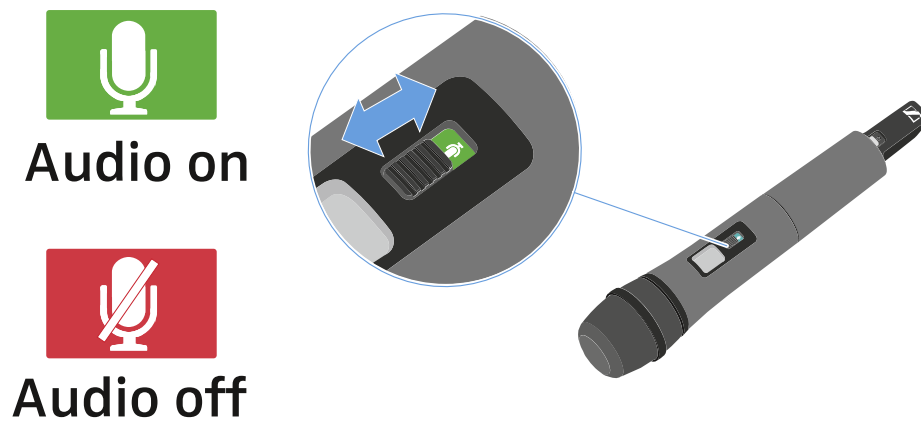



SK-XSW bodypack transmitter

Product overview

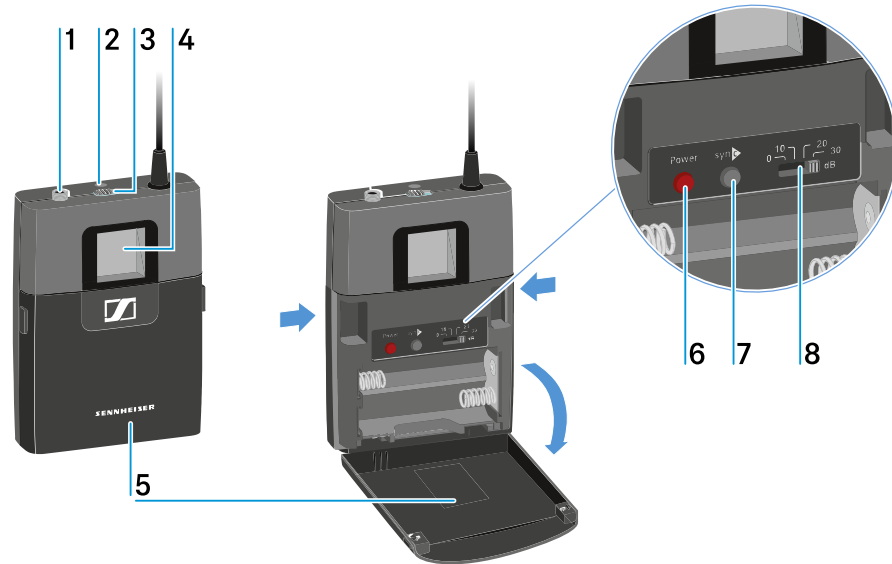

1 3.5 mm input jack socket

- see [Connecting a microphone to the bodypack transmitter](#)
- see [Connecting an instrument or line source to the bodypack transmitter](#)

2 LED

- Green: the radio link is established
- Flashing red/green: pairing active (see [Establishing a radio link | Synchronizing the receiver and transmitter](#))
- Flashing red: low battery (see [Inserting and removing the batteries](#))

3 Mute switch

- see [Muting the bodypack transmitter](#)

4 Display panel

- see [Information on the handheld transmitter's display](#)

5 Battery compartment cover

- see [Inserting and removing the batteries](#)



6 **ON/OFF (Power)** button

- see [Switching the bodypack transmitter on and off](#)

7 **SYNC** button

- see [Establishing a radio link | Synchronizing the receiver and transmitter](#)

8 **Sensitivity** switch

- see [Setting the input sensitivity](#)



Inserting and removing the batteries

You need two AA 1.5 V batteries to operate the handheld transmitter.

- ▶ Press the two catches and open the battery compartment cover.
- ▶ Insert the batteries as shown in the figure. Observe correct polarity.

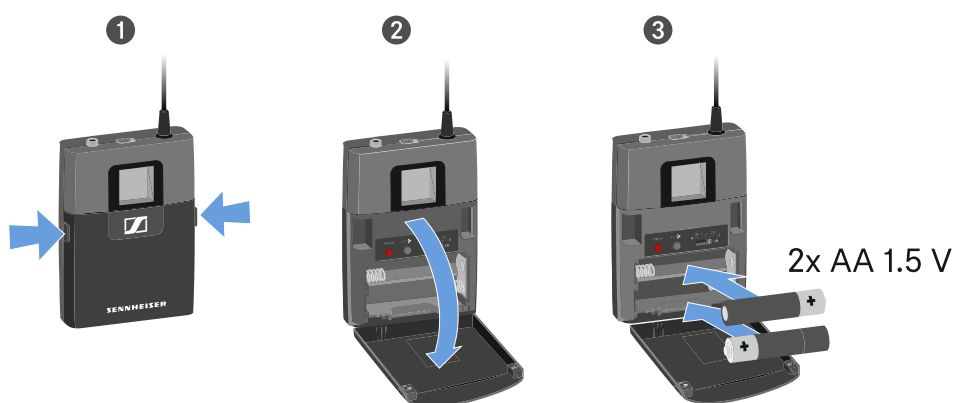

- ▶ Close the battery compartment.
 - ✓ The cover locks into place with an audible click.

Battery status

Battery charge status in the display:

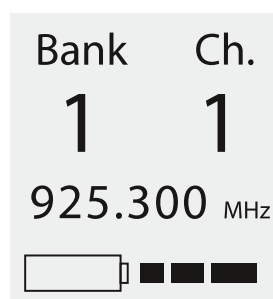

	~ 10 h
	~ 7 h
	~ 3 h
	Low Batt

Charge status is critical (LOW BATT):



SK-XSW



SKM-XSW

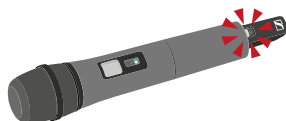

EM-XSW 1 /EM-XSW 1 DUAL

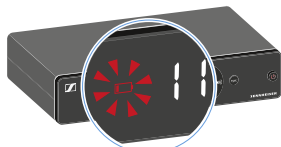

EM-XSW 2





Connecting a microphone to the bodypack transmitter

To connect a microphone to the bodypack transmitter:

- ▶ Insert the cable's 3.5 mm jack plug into the socket on the bodypack transmitter as shown in the diagram.
- ▶ Screw the plug's coupling ring onto the audio socket thread of the bodypack transmitter.

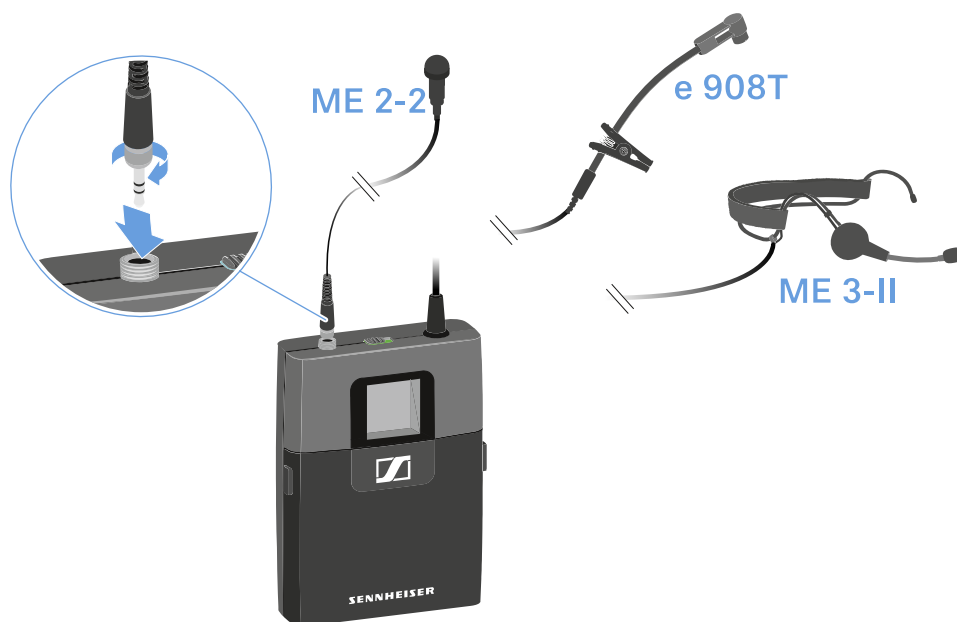



Connecting an instrument or line source to the bodypack transmitter

You can connect instruments or audio sources with a line level to the bodypack transmitter.

To do so, you require the Sennheiser CI 1-N cable (6.3 mm jack plug to lockable 3.5 mm jack plug).

To connect an instrument or line source to bodypack transmitter:

- ▶ Insert the cable's 3.5 mm jack plug into the socket on the bodypack transmitter as shown in the diagram.
- ▶ Screw the plug's coupling ring onto the audio socket thread of the bodypack transmitter.

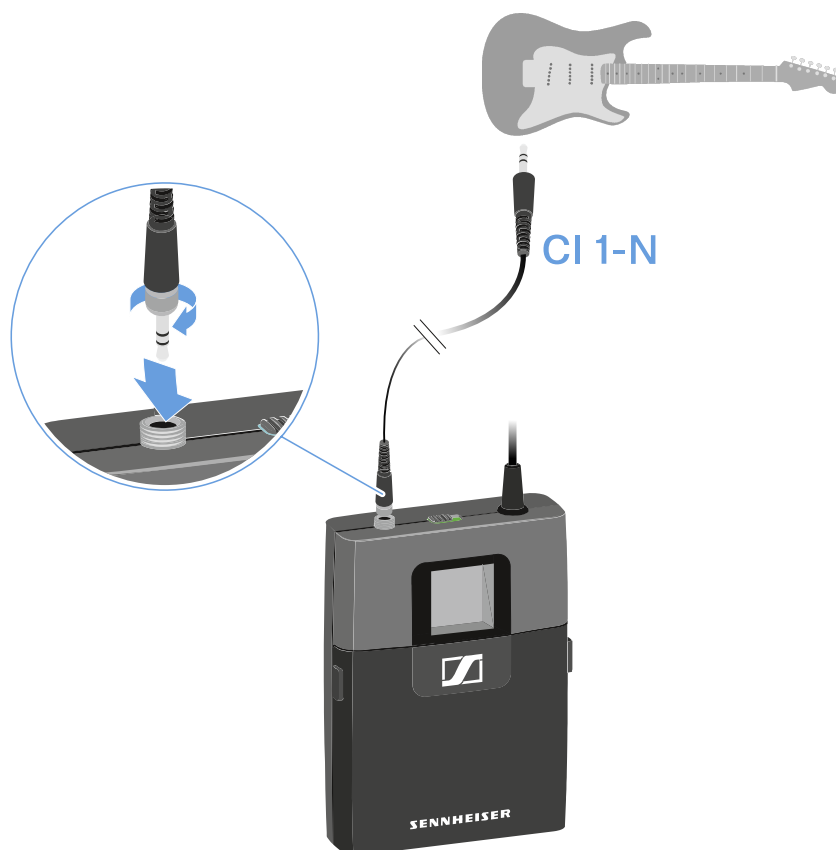



Switching the bodypack transmitter on and off

To switch the bodypack transmitter on:

- ▶ Short-press the **ON/OFF** button.

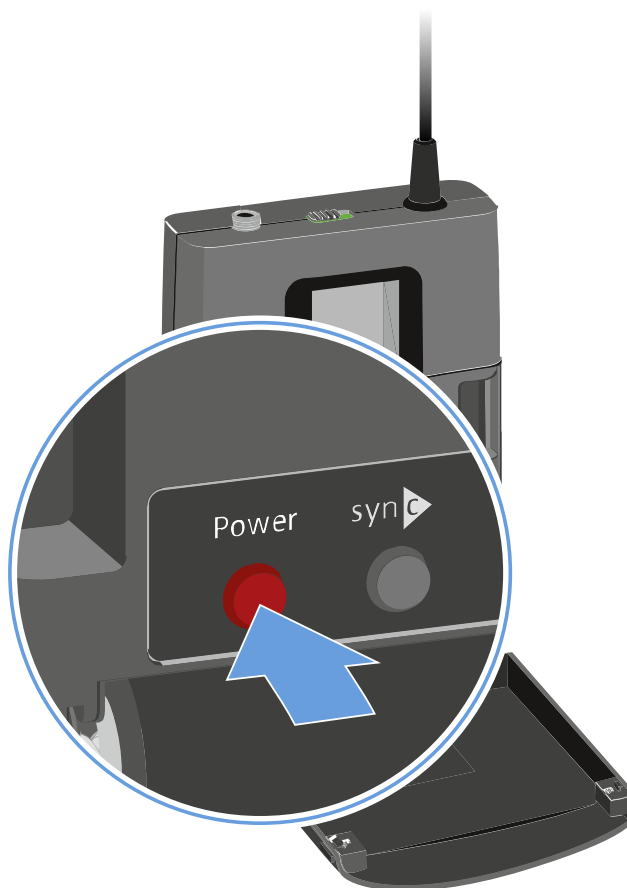

- ✓ The transmitter switches on. The LED lights up.

To switch the bodypack transmitter off:

- ▶ Hold down the **ON/OFF** button until the LED switches off.



Establishing a connection to the receiver

To establish a radio link between the transmitter and the receiver, the devices must be synchronized.

See [Establishing a radio link | Synchronizing the receiver and transmitter](#).



Information on the handheld transmitter's display

You can view the following information on the transmitter display.

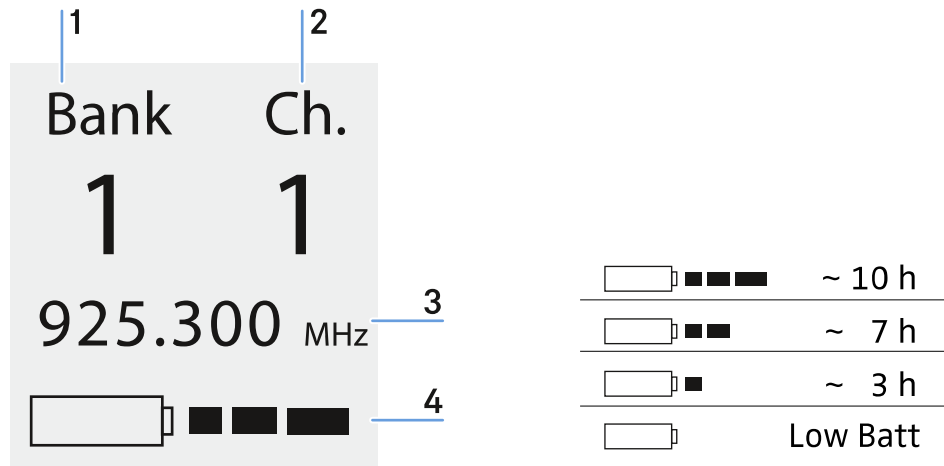

1 Frequency bank

- EM-XSW 1 [Setting options on the front of the device](#) | [Setting options on the front of the device](#)
- EM-XSW 1 Dual [Setting options on the front of the device](#) | [Setting options on the front of the device](#)
- EM-XSW 2 [SCAN menu item](#) | [PRESET menu item](#) | [TUNE menu item](#)

2 Channel

- EM-XSW 1 [Setting options on the front of the device](#) | [Setting options on the front of the device](#)
- EM-XSW 1 Dual [Setting options on the front of the device](#) | [Setting options on the front of the device](#)
- EM-XSW 2 [SCAN menu item](#) | [PRESET menu item](#) | [TUNE menu item](#)

3 Frequency

- EM-XSW 1 [Setting options on the front of the device](#) | [Setting options on the front of the device](#)
- EM-XSW 1 Dual [Setting options on the front of the device](#) | [Setting options on the front of the device](#)
- EM-XSW 2 [SCAN menu item](#) | [PRESET menu item](#) | [TUNE menu item](#)

4 Battery

- SKM XSW [Inserting and removing the batteries](#)
- SK-XSW [Inserting and removing the batteries](#)



Setting the input sensitivity

Use the Sensitivity switch to adjust the level of the audio signal sent to the receiver.

- ▶ Press the two catches and open the battery compartment cover.
- ▶ Adjust the input sensitivity using the **Sensitivity** switch.
- ▶ Pay attention to the level indicator on the receiver display.

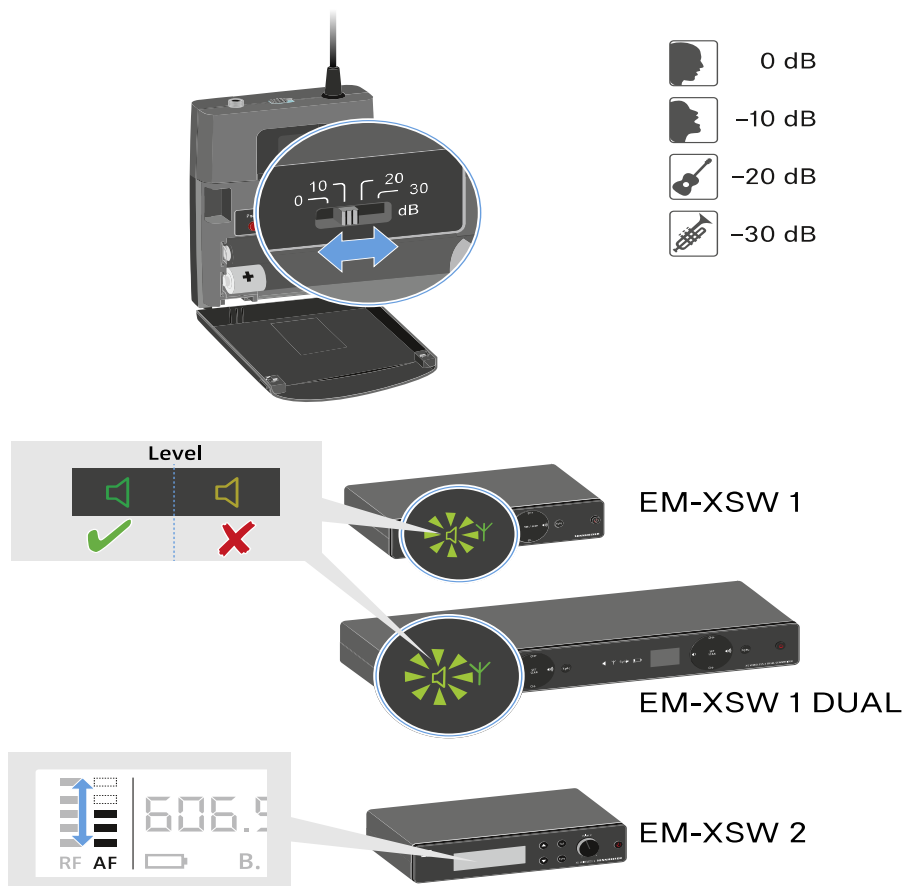



Muting the bodypack transmitter

You can mute the audio signal using the mute switch.

- ▶ Slide the mute switch to the desired position to mute or activate the audio signal.

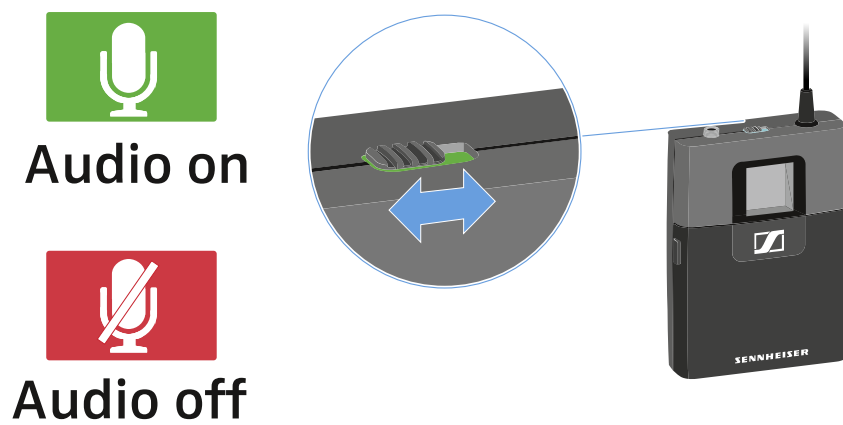



Establishing a radio link | Synchronizing the receiver and transmitter

- i** Conditions and restrictions for using frequencies
There may be special conditions and restrictions for using frequencies in your country.
Before putting the product into operation, find the information for your country at the following address: sennheiser.com/sifa.

To establish a radio link between the transmitter and receiver, we recommend the following procedure.

- i** To successfully pair a receiver and a transmitter, both devices must have the same frequency range.

Step 1: Set a free frequency on the receiver

We recommend using the **AUTO SCAN** function, as this is the most reliable way to identify free frequencies (EM-XSW 1: [Setting the frequency automatically \(AUTO SCAN\)](#) | EM-XSW 1 DUAL: [Setting the frequency automatically \(AUTO SCAN\)](#) | EM-XSW 2: [SCAN menu item](#)).

If you know free frequencies in your area, you can also set the frequency manually (EM-XSW 1: [Setting the frequency manually](#) | EM-XSW 1 DUAL: [Setting the frequency manually](#) | EM-XSW 2: [TUNE menu item](#)).



Step 2: Synchronize the receiver and transmitter

- ▶ Press and hold the **SYNC** button on the transmitter.

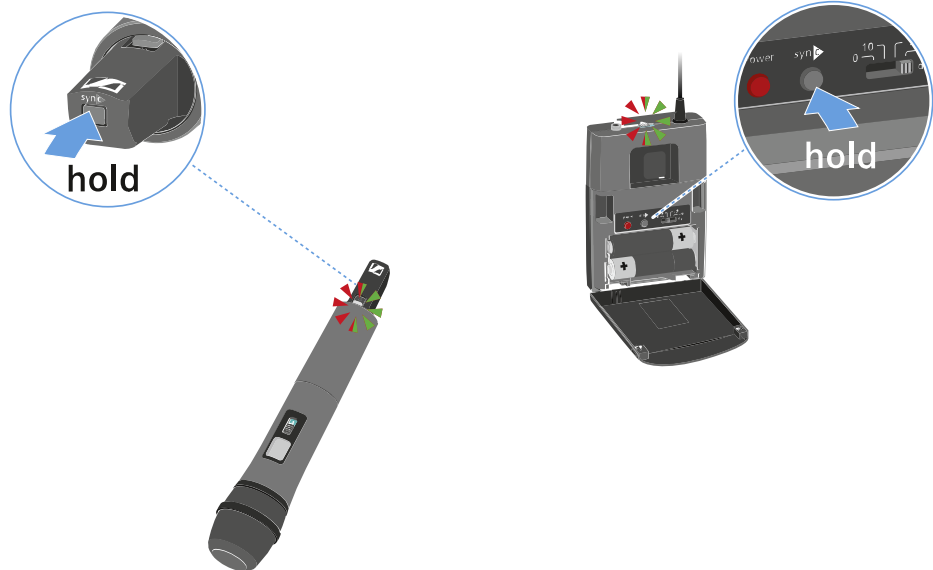

- ✓ The LED flashes alternately red and green.

- ▶ While the LED is flashing, short-press the **SYNC** button on the receiver.

EM-XSW 1 / EM-XSW 1 DUAL

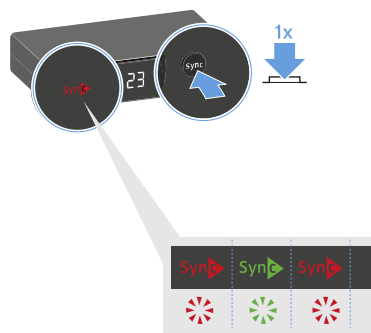

EM-XSW 2

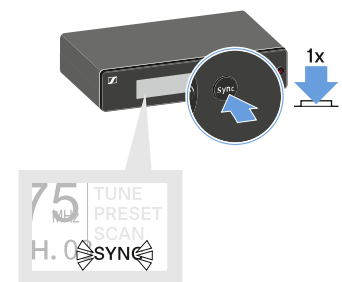



- ✓ The transmitter and receiver are synchronized and the connection is established.

EM-XSW 1 / EM-XSW 1 DUAL

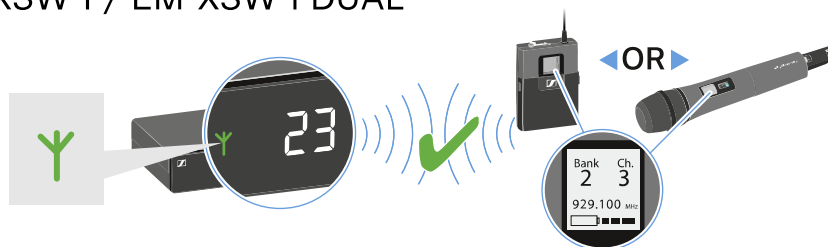

EM-XSW 2





Cleaning and maintenance

Note the following information when cleaning and maintaining products of the Evolution Wireless Digital series.

NOTICE



Liquids can damage the electronics of the product

Liquids entering the product housing can cause a short-circuit and damage the electronics.

- ▶ Keep all liquids away from the products.
- ▶ Do not use any solvents or cleansing agents.
- ▶ Disconnect the mains-operated products from the power supply system and remove rechargeable batteries and batteries (if present) before you begin cleaning.
- ▶ Clean all products only with a soft, dry cloth.

- ▶ Note the special cleaning instructions below for the following products.

Cleaning the sound inlet basket of the microphone module

- ▶ Unscrew the top sound inlet basket from the microphone module by turning it counterclockwise.
- ▶ Remove the foam insert.
You can clean the sound inlet basket in two ways:
 - Use a slightly damp cloth to clean the top sound inlet basket from the inside and outside.
 - Use a brush and rinse with clean water.
- ▶ If necessary, clean the foam insert with a mild detergent or replace the foam insert.
- ▶ Dry the top sound inlet basket and foam insert.
- ▶ Reinsert the foam insert.
- ▶ Screw the sound inlet basket back onto the microphone module.
- ▶ From time to time, you should also clean the microphone module contacts: Wipe the contacts of the microphone module with a soft, dry cloth.

Cleaning the bodypack transmitter contacts

- ▶ Wipe the contacts with a dry cloth.



4. Specifications

All specifications at a glance.

System

Modulation

- Wideband FM

Frequency ranges

- A: 548 - 572 MHz
- GB: 606 - 630 MHz
- B: 614 - 638 MHz
- BC: 670 - 694 MHz
- C: 630 - 662 MHz
- D: 766 - 790 MHz
- JB: 806.125 - 809.750 MHz
- E: 821 - 832 MHz & 863 - 865 MHz
- K: 925 - 937.5 MHz
- Further details: [Frequency ranges](#)

Switching bandwidth

- up to 24 MHz

Frequencies

- XSW 1:
 - 8 frequency banks, each with up to 10 factory-preset channels
- XSW 2:
 - adjustable in 25 kHz steps
 - 8 frequency banks, each with up to 12 factory-preset channels

Transmitter synchronization

- XSW 1:
 - 2.4 GHz, RF power < 3 mW, MSK (only active during synchronization)
- XSW 2:
 - 2.4 GHz, RF power < 3 mW, Low Power OQPSK (only active during synchronization)

Signal-to-noise ratio

- ≥ 103 dBA



Audio THD

- $\leq 0,9\%$

Operating temperature range

- $0\text{ }^{\circ}\text{C} - +40\text{ }^{\circ}\text{C}$ ($32\text{ }^{\circ}\text{F} - 104\text{ }^{\circ}\text{F}$)

Storage temperature range

- $-20\text{ }^{\circ}\text{C} - +70\text{ }^{\circ}\text{C}$ ($-4\text{ }^{\circ}\text{F} - 158\text{ }^{\circ}\text{F}$)

Relative humidity

- max. 95 % (non-condensing)



EM-XSW 1 stationary receiver

Receiver principle

- double superheterodyne

Diversity principle

- Antenna switching diversity via internal antennas

Sensitivity (at peak deviation)

- < 3 μ V at 52 dB(A)eff S/N

AF frequency response

- 50 - 16.000 Hz (-3 dB)

Max. AF output voltage (at peak deviation, 1 kHz AF)

- 6.3 mm jack socket (unbalanced): +6 dBu
- XLR socket (balanced): +12 dBu

Audio adjustment range

- 45 dB, adjustable in 5 dB steps

Power supply

- 12 V DC nom. / 300 mA

Squelch

- Adjustable from 3 dB μ V up to 28 dB μ V (combined with pilot tone)

Line/Mic level

- 20 dB, switchable

Housing material

- rugged ABS housing

Dimensions

- approx. 200 x 42 x 127 mm

Weight

- approx. 340 g



EM-XSW 1 DUAL rack receiver

Receiver principle

- double superheterodyne

Diversity principle

- Antenna switching diversity via internal antennas

Sensitivity (at peak deviation)

- $< 3 \mu\text{V}$ at 52 dB(A)eff S/N

AF frequency response

- 50 - 16.000 Hz (-3 dB)

Max. AF output voltage (at peak deviation, 1 kHz AF)

- 6.3 mm jack socket (unbalanced): +6 dBu
- XLR socket (balanced): +12 dBu

Audio adjustment range

- 45 dB, adjustable in 5 dB steps

Power supply

- 12 V DC nom. / 500 mA

Squelch

- Adjustable from 3 dB μV up to 28 dB μV (combined with pilot tone)

Line/Mic level

- 20 dB, switchable

Housing material

- rugged ABS housing

Dimensions

- approx. 320 x 42 x 127 mm

Weight

- approx. 610 g



EM-XSW 2 stationary receiver

Receiver principle

- double superheterodyne

Diversity principle

- True Diversity

Sensitivity (at peak deviation)

- < 3 μ V at 52 dB(A)eff S/N

AF frequency response

- 50 - 16.000 Hz (-3 dB)

Max. AF output voltage (at peak deviation, 1 kHz AF)

- 6.3 mm jack socket (unbalanced): +6 dBu
- XLR socket (balanced): +12 dBu

Audio adjustment range

- 40 dB, adjustable in 5 dB steps

Power supply

- 12 V DC nom. / 300 mA

Squelch

- Adjustable from 3 dB μ V up to 28 dB μ V (combined with pilot tone)

Line/Mic level

- 20 dB, switchable

Housing material

- Rugged metal housing

Dimensions

- approx. 200 x 42 x 127 mm

Weight

- approx. 680 g



SKM-XSW handheld transmitter

Transmission power

- 10 mW

AF frequency response

- SKM 825-XSW
 - 80 - 14.000 Hz
- SKM 835-XSW
 - 80 - 16.000 Hz
- SKM 865-XSW
 - 80 - 16.000 Hz

Power supply

- 2 AA batteries, 1.5 V

Operating time

- approx. 10 hours

Microphone type

- SKM 825-XSW
 - Dynamic
- SKM 835-XSW
 - Dynamic
- SKM 865-XSW
 - Capacitor, pre-polarized

Input sensitivity (capsule)

- SKM 825-XSW
 - 1,5 mV/Pa
- SKM 835-XSW
 - 1,5 mV/Pa
- SKM 865-XSW
 - 1,8 mV/Pa

Pick-up pattern

- SKM 825-XSW
 - Cardioid
- SKM 835-XSW
 - Cardioid
- SKM 865-XSW
 - Super-cardioid



Adjustment range of transmitter sensitivity

- 0 to -30 dB, adjustable in 10 dB steps

Housing material

- rugged ABS housing

Dimensions

- approx. 260 x 50 mm

Weight

- approx. 245 g



SK-XSW bodypack transmitter

Transmission power

- 10 mW

AF frequency response

- 50 - 16.000 Hz (Line)
- 80 - 16.000 Hz (Mic)

Audio input

- 3.5 mm jack socket

Max. input voltage (Mic/Line) at 3% THD

- typ. 1,5 V rms Mic @ -30 dB gain
- typ. 2,6 V rms Line @ -30 dB gain

Power supply

- 2 AA batteries, 1.5 V

Operating time

- approx. 10 hours

Adjustment range of transmitter sensitivity

- 0 to -30 dB, adjustable in 10 dB steps

Housing material

- rugged ABS housing

Dimensions

- approx. 71 x 96 x 28 mm

Weight

- approx. 95 g



5. Regulatory information

Information on manufacturer declarations, environmental and disposal notices, and terms of use.

XSW 1 and XSW 2

Model: EM-XSW 1, EM-XSW 1 DUAL, EM-XSW 2, SK-XSW, SKM XSW

China

China RoHS

部件名称 (Parts)	有害物质										产品环保年限 EFUP
	铅 (Pb)	汞 (Hg)	镉 (Cd)	六价铬 (Cr6+)	多溴联苯 (PBB)	多溴二苯醚 (PBDE)	邻苯二甲酸二 (2-乙基己)酯 (DEHP)	邻苯二甲 酸丁苯酯 (BBP)	邻苯二甲 酸二丁酯 (DBP)	邻苯二甲 酸二异丁酯 (DIBP)	
金属部件 (Metal parts)	x	o	o	o	o	o	o	o	o	o	15
电路模块 (Circuit Modules)	x	o	o	o	o	o	o	o	o	o	15
电缆及电缆组件 (Cables & Cable Assemblies)	x	o	o	o	o	o	o	o	o	o	15
电路开关 - 如果包含 (Circuit Breakers - if available)	x	o	o	o	o	o	o	o	o	o	15
外部电力适配器 - 如果包含 (external power supply - if available)	x	o	o	o	o	o	o	o	o	o	10
电池 - 如果包含 (battery - if available)	x	o	o	o	o	o	o	o	o	o	5

本表格依据 SJ/T 11364 的规定编制。

o: 表示该有害物质在该部件所有均质材料中的含量均在 GB/T 26572 规定的限量要求以下。

x: 表示该有害物质至少在该部件的某一均质材料中的含量超出 GB/T 26572 规定的限量要求。

