



# Spectera Solution

PDF export of the original HTML manual



# Contents

|  |     |
|--|-----|
| 1. Preface.....                                      | 4   |
| 2. Quick start.....                                  | 5   |
| 3. Product information.....                          | 7   |
| Spectera System.....                                 | 7   |
| Base Station.....                                    | 8   |
| SEK.....   | 10  |
| DAD.....   | 11  |
| WebUI.....   | 12  |
| Accessories.....                                     | 13  |
| Accessories for the Base Station.....                | 13  |
| Accessories for the SEK.....                         | 15  |
| Accessories for the DAD.....                         | 16  |
| CHG 70N-C network-enabled charger.....               | 17  |
| BA 70 rechargeable battery and L 70 USB charger..... | 19  |
| Modular L 6000 charger.....                          | 20  |
| Charging modules for L 6000 charger.....             | 22  |
| 4. Instruction manual.....                           | 25  |
| Spectera.....  | 25  |
| Base Station.....                                    | 26  |
| SEK.....   | 74  |
| DAD.....   | 101 |
| CHG 70N-C charger.....                               | 112 |
| L 70 USB charger.....                                | 125 |
| Modular L 6000 charger.....                          | 128 |
| Cleaning and maintenance.....                        | 146 |
| WebUI.....   | 147 |
| Getting started.....                                 | 147 |
| Configuration.....                                   | 167 |
| Frequency Scan.....                                  | 222 |
| Audio Levels.....                                    | 226 |
| Audio inputs and outputs.....                        | 227 |
| Changing the device password.....                    | 228 |
| 5. Knowledge base.....                               | 231 |
| Network guide.....                                   | 231 |
| Introduction.....                                    | 231 |



|   |     |
|---|-----|
| General requirements.....                                   | 232 |
| Network setups.....   | 235 |
| Ports, protocols and services.....                          | 239 |
| Best practice.....  | 243 |
| Security guide.....   | 246 |
| Introduction.....   | 246 |
| Key product security features.....                          | 248 |
| How to use the security features.....                       | 252 |
| Troubleshooting.....  | 259 |
| License activation fails.....                               | 259 |
| No device access via the WebUI.....                         | 261 |
| The Base Station cannot be found.....                       | 262 |
| 6. Specifications.....                                      | 263 |
| Spectera System.....  | 263 |
| Base Station.....   | 265 |
| SEK.....  | 268 |
| DAD.....  | 270 |
| WebUI.....  | 272 |
| CHG 70N-C charger.....                                      | 273 |
| BA 70 rechargeable battery.....                             | 275 |
| L 70 USB charger.....                                       | 276 |
| Modular L 6000 charger.....                                 | 277 |
| LM 6060   LM 6061   LM 6062   LM 6070 charging modules..... | 279 |



# 1. Preface

## **PDF Export of the Original HTML Manual**

This PDF document is an automatic export of an interactive set of HTML manuals. Some content and interactive elements may not be included in the PDF because they cannot be displayed in this format. In addition, automatically generated page breaks may cause related content to be slightly shifted. We can therefore only guarantee the completeness of the information in the HTML manual and recommend using it. You can find it in the Documentation Portal at [www.sennheiser.com/documentation](http://www.sennheiser.com/documentation).



## 2. Quick start

All necessary information for activating the license and configuring the required ports of the device.

When starting up the Base Station for the first time, it is necessary to have a direct internet connection to activate the license. Additionally, certain ports must be enabled (especially for the organization/enterprise firewall) for communication between software and devices.

### 1. Connect the Base Station to a network:

- ▶ Plug one side of the network cable into the **Control** socket.

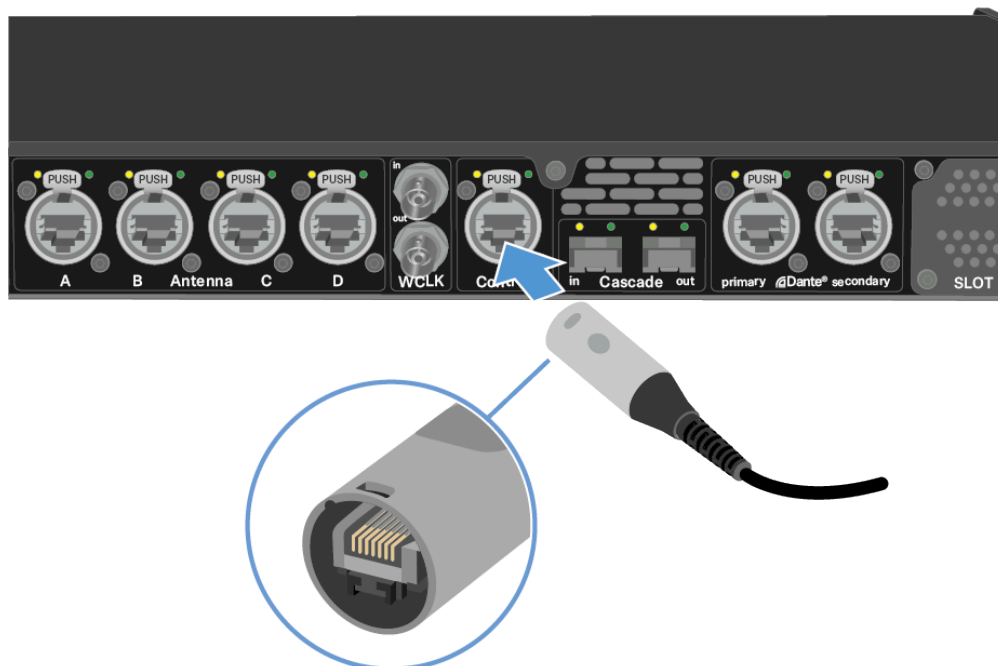

- ▶ Plug the other side of the network cable to a switch or router.
- ✔ The Base Station has been connected to a network.

### 2. Enable necessary ports for activation:

- ▶ Please contact your IT administrator to provide Internet access to the License Server and any NTP server by opening the required network ports and to provide DNS settings via DHCP to the device.

| Address          | Port | Protocol    | Type    | Service                   | Usage                 |
|------------------|------|-------------|---------|---------------------------|-----------------------|
| my.nalpeiron.com | 80   | HTTPS (TCP) | Unicast | Sennheiser License Server | Activation of devices |



ANY (see list of [NTP servers](#)) 123 NTP Unicast NTP Time Server Synchronize system time

**i** You can find the complete overview of all ports at [Ports, protocols and services](#).

3. Ensure that the network has an Internet connection and activate the license:

**NOTICE**



**License activation requires a direct Internet connection to the device**

In order to activate the Base Station using the 18-digit license code, a direct Internet connection is required.

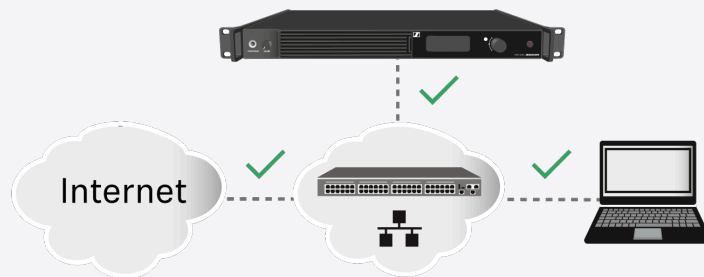

- ▶ Please connect your Base Station directly to a network with Internet access via a switch or router. For more information, refer to the chapter [Connecting to a network](#).
- ▶ Direct connections via laptop etc. are not supported for activation!

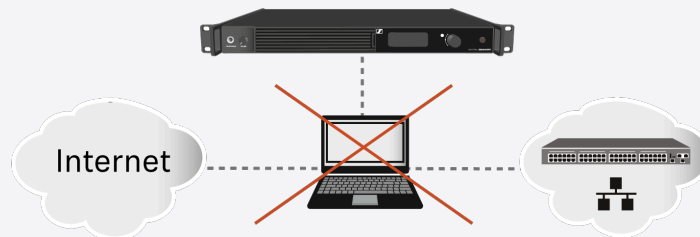

- ▶ The Internet is only required once for activation.

- ▶ If you want to activate a license via Spectera WebUI, follow the steps described here: [Activating a license \(WebUI\)](#).



### 3. Product information

All information about the product, the scope of delivery, the available accessories and the requirements for operating your Spectera solution.

#### Spectera System

Sensing Capabilities - Audio detection and transmission

Spectera devices (Base Station, DAD, SEK) build audio transmission system for professional use. Once paired, SEK mobile devices can transmit audio signals captured by a connected microphone over radio frequencies. Due to its bi-directionality, the SEK is able to receive audio signals from DAD and the sound comes out of the headphones, if any connected. Here how it works:

**Transmission:**

1. The microphone connected to the SEK picks up the sound and converts it into electrical signals.
2. The SEK then prepares these signals for transmission by amplifying and modifying them.
3. The signals are sent over radio waves to the DAD Antenna.
4. The DAD antenna changes the radio back into electrical signals and sent them to the Base Station for further audio processing.

**Receiving:**

1. The Base Station forward audio signals to the DAD Antenna.
2. These signals are then prepared for transmission by boosting and modifying them.
3. The signals are sent over radio waves to the SEK mobile devices.
4. The SEK changes the radio back into electrical signals and at a further stage, sound will be directed to connected headphones.



## Base Station



**Base Station** | 1350 - 1525 MHz | Art. no. 509162

The license for the Base Station is available in the following versions:

| Name                   | Art. no. | Frequency range   | Certified Countries*                 |
|------------------------|----------|---|--------------------------------------|
| SPECTERA LIC (ZONE 01) | 700 532  | UHF (470 - 608 MHz, 630 - 698 MHz)<br>1G4 (1350 - 1400 MHz)                       | EU + EFTA, United Kingdom, Turkey    |
| SPECTERA LIC (ZONE 02) | 700 533  | UHF (470 - 608 MHz, 657 - 663 MHz)<br>1G4 (1435 - 1525 MHz Certification pending) | USA                                  |
| SPECTERA LIC (ZONE 03) | 700 534  | UHF (470 - 608 MHz, 657 - 663 MHz)  | Canada                               |
| SPECTERA LIC (ZONE 04) | 700 535  | UHF (470 - 534 MHz, 534 - 608 MHz, 630 - 698 MHz)                                 | Singapore                            |
| SPECTERA LIC (ZONE 05) | 700 536  | UHF (470 - 608 MHz, 630 - 698 MHz)<br>1G4 (1350 - 1400 MHz)                       | South Africa - Certification pending |
| SPECTERA LIC (ZONE 06) | 700 537  | UHF (470 - 608 MHz, 630 - 694 MHz)  | Malaysia, Qatar                      |
| SPECTERA LIC (ZONE 07) | 700 538  | UHF (470 - 510 MHz)   | Israel - Certification pending       |
| SPECTERA LIC (ZONE 08) | 700 539  | UHF (487 - 608 MHz, 630 - 694 MHz)  | Indonesia                            |
| SPECTERA LIC (ZONE 09) | 700 540  | UHF (470 - 608 MHz, 630 - 694 MHz)<br>1G4 (1350 - 1400 MHz)                       | United Arab Emirates                 |
| SPECTERA LIC (ZONE 10) | 700 541  | UHF (470 - 608 MHz, 630 - 698 MHz)  | Philippines                          |
| SPECTERA LIC (ZONE 11) | 700 542  | UHF (520 - 608 MHz, 630 - 694 MHz)  | Australia                            |
| SPECTERA LIC (ZONE 12) | 700 543  | UHF (510 - 606 MHz)   | New Zealand                          |
| SPECTERA LIC (ZONE 13) | 700 544  | UHF (479 - 565 MHz)   | Hong Kong                            |



| Name                      | Art. no.   | Frequency range    | Certified Countries* |
|---------------------------|------------|--------------------|----------------------|
| SPECTERA LIC<br>(ZONE 14) | 700<br>728 | UHF (470-0608 MHz) | Egypt, Mexico        |

\* It is the responsibility of the user to inform themselves about the current local regulatory and certification requirements and to comply with them using wireless systems.

**i** You can find more detailed information about the Base Station in the following sections:

- **Startup and operation:** [Base Station](#)
- **Specifications:** [Base Station](#)



## SEK



The SEK is available in the following versions:

**SEK UHF** | 470 - 698 MHz | Art. no. 509164

**SEK 1G4** | 1350 - 1525 MHz | Art. no. 509163

**i** You can find more detailed information about the SEK in the following sections:

- **Startup and operation:** [SEK](#)
- **Specifications:** [SEK](#)



## DAD

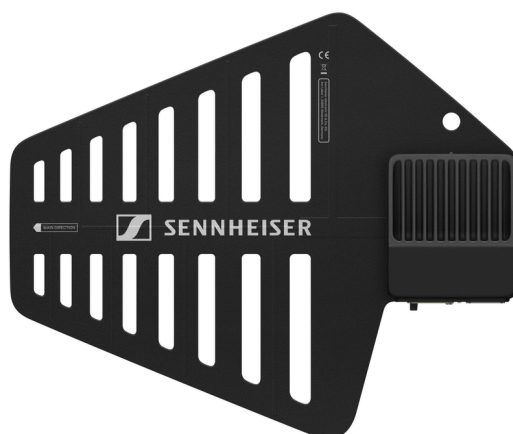

**DAD (UHF)**



**DAD (1G4)**

The Digital Antenna Directional (DAD) is available in the following versions:

**DAD UHF** | 470 - 698 MHz | Art. no. 509169

**DAD 1G4** | 1350 - 1525 MHz | Art. no. 509170

**i** You can find more detailed information about the DAD in the following sections:

- **Startup and operation:** [DAD](#)
- **Specifications:** [DAD](#)



## Product information

Information about supported devices, design, functionality and the main features of the software at a glance.

Spectera WebUI is a self-hosted, browser-based and user-friendly interface for the dedicated control and monitoring of Spectera devices.

The WebUI offers you an intuitive **Configuration** with essential remote control and monitoring functions, such as IEM volume, latency, audio level and settings, RF status, battery status and much more. The **Frequency Scan** provides a continuous spectrum scan via Spectera's innovative DAD antenna. Plus, the **Audio Levels view** shows all inputs and outputs of the connected interfaces on one page. All audio channels and links are summarized in the **Audio IO** view and can be easily adjusted.

### Key Features

- Self-hosted, browser-based and user-friendly interface for the dedicated control and monitoring of Spectera devices.
- Online interface for full system management.
- A tool-tip provides contextual additional information that appears when hovering over an element with the mouse.
- Complete remote control and monitoring of all Spectera ecosystem components, including the Base Station, DAD antenna, and SEK bodypacks, all on a single page.
- Unprecedented remote control and monitoring capabilities, plus visibility of:
  - Interference Level (IF)
  - Receive Signal Strength Indication (RSSI)
  - Link Quality Input (LQI)
  - IEM settings (Interface, CH, Mode, Balance, Volume)
  - MIC settings (Mic/Line, Cable Emulation, Low Cut, Preamp Gain, Test Tone, Mode, CH)
- Continuous spectrum scanning via DAD antenna available.
- Regional license key for activating the Base Station.



## Accessories

### Accessories for the Base Station

#### MADI Cards

MADI Card (BNC) for Base Station | Art. no. 509293



MADI Card (OM) for Base Station | Art. no. 509295

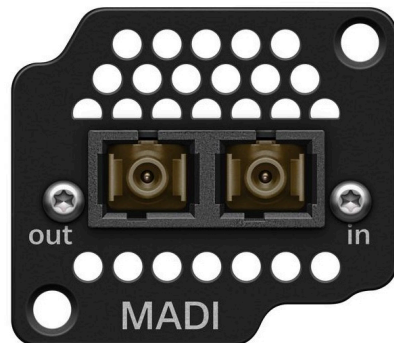

- See [Installing slot-in cards](#)

#### Spectera Filter set

Three exchangeable **filters** for the Base Station | Art. no. 700073



- See [Changing the fan filter](#)



## Accessories for the SEK

### Spectera SEK Antenna

SEK Antenna (UHF) | 470 - 698 MHz | Art. no. 700066



SEK Antenna (1G4) | 1350 - 1525 MHz | Art. no. 700067



- See [Mounting the antenna](#)

### Spectera SEK Belt Clip

SEK Belt Clip | Art. no. 700071

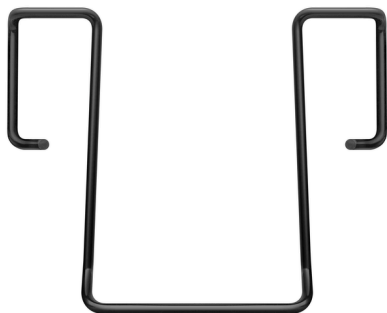

- See [Changing the belt clip](#)

### 3-pin protective cap MIC/LINE

Exchangeable protective **cap** for the microphone / instrument 3-pin connector | Art. no. 700072



- See [Using the protection cap](#)



## Accessories for the DAD

Optional cables for DAD



**Antenna cable cat 5e** | 10 m | Art. no. 700068

**Antenna cable cat 5e** | 25 m | Art. no. 700069

**Antenna cable cat 5e** | 50 m | Art. no. 700070

- See [Connecting/disconnecting the antenna](#)



## CHG 70N-C network-enabled charger



**CHG 70N-C** | Charger | Art. no. 700332



**CHG 70N-C + PSU KIT** | CHG 70N-C charger with NT 12-35 CS power supply unit | Art. no. 700333

**i** You can find more detailed information about the CHG 70N-C in the following sections:

- **Startup and operation:** [CHG 70N-C charger](#)
- **Specifications:** [CHG 70N-C charger](#) | [BA 70 rechargeable battery](#)



## BA 70 rechargeable battery and L 70 USB charger



**BA 70** | Rechargeable battery | Art. no. 508860

**L 70 USB** | Charger | Art. no. 508861

**EW-D CHARGING SET** | L 70 USB charger with two BA 70 rechargeable batteries | Art. no. 508862

**i** You can find more detailed information about the BA 70 rechargeable battery and the L 70 USB charger in the following sections:

- **Startup and operation:** [L 70 USB charger](#)
- **Specifications:** [L 70 USB charger](#) | [BA 70 rechargeable battery](#)



## Modular L 6000 charger

The L 6000 charger is used to charge the BA 60, BA 61, BA 62 and BA 70 rechargeable batteries.

The charging modules LM 6060 (for the BA 60), LM 6061 (for the BA 61), LM 6062 (for the BA 62) or LM 6070 (for the BA 70) are required to do so. The rechargeable batteries and charging modules are available separately.



- **L 6000 EU** | Article no. 507300

**i** You can find more detailed information about the L 6000 charger and the LM 6060, LM 6061, LM 6062 and LM 6070 charging modules in the following sections:

- **Installation and Operation:** [Modular L 6000 charger](#)
- **Specifications:** [Modular L 6000 charger](#) and [LM 6060 | LM 6061 | LM 6062 | LM 6070 charging modules](#)

### Delivery includes

- 1 L 6000 charger
- 1 mains cables (EU, UK, or US variant)
- 4 dummy caps including screws (preassembled)
- 4 rubber feet
- 1 quick guide
- 1 manual with safety instructions
- 1 manual with technical data and manufacturer declarations

### Product overview

**View with the charging modules and rechargeable batteries inserted:**



View with the LM 6060 charging modules without rechargeable batteries inserted:



View with the LM 6061 charging modules without rechargeable batteries inserted:





## Charging modules for L 6000 charger

The following **charging modules** are available for the **L 6000** charger:

### **LM 6060**

The LM 6060 charging module is installed in the L 6000 charger to charge the BA 60 rechargeable battery.

**LM 6060** | Article no. 507198



### **LM 6061**

The LM 6061 charging module is installed in the L 6000 charger to charge the BA 61 rechargeable battery.

**LM 6061** | Article no. 507199



**LM 6062**

The LM 6062 charging module is installed in the L 6000 charger to charge the BA 62 rechargeable battery.

**LM 6062** | Article no. 508516





### LM 6070

The LM 6070 charging module is installed in the L 6000 charger to charge the BA 70 rechargeable battery of the Evolution Wireless Digital series.

**LM 6070** | Article no. 509457





## 4. Instruction manual

Detailed description of the start-up and operation of your selected hardware and software product.

### Important Information on License Activation

#### NOTICE



**License activation requires a direct Internet connection to the device**

In order to activate the Base Station using the 18-digit license code, a direct Internet connection is required.

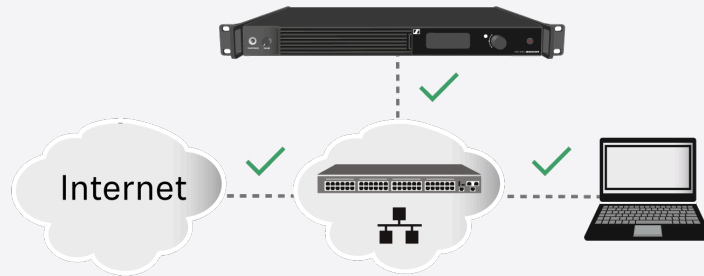

- ▶ Please connect your Base Station directly to a network with Internet access via a switch or router. For more information, refer to the chapter [Connecting to a network](#).
- ▶ Direct connections via laptop etc. are not supported for activation!

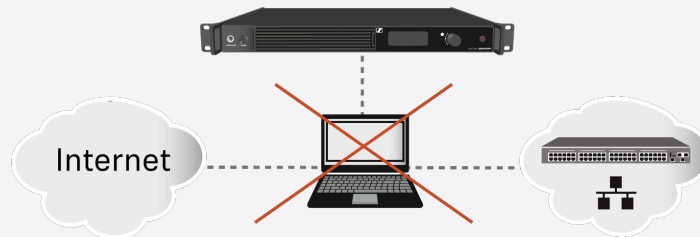

- ▶ The Internet is only required once for activation.

## Instruction manual

Detailed description of the start-up and operation of your selected hardware.



**i** Instruction manuals about controlling the Spectera System via LinkDesk and Spectera WebUI can be found here:

- Instruction manual [LinkDesk](#)
- Instruction manual [WebUI](#)

### Important Information on License Activation

#### NOTICE



**License activation requires a direct Internet connection to the device**

In order to activate the Base Station using the 18-digit license code, a direct Internet connection is required.

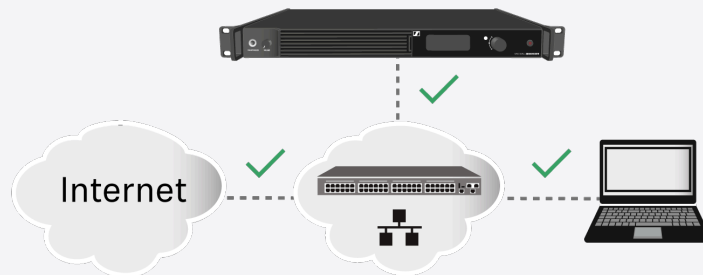

- ▶ Please connect your Base Station directly to a network with Internet access via a switch or router. For more information, refer to the chapter [Connecting to a network](#).
- ▶ Direct connections via laptop etc. are not supported for activation!

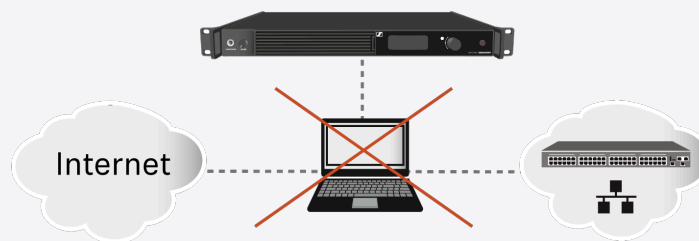

- ▶ The Internet is only required once for activation.

## Base Station

### Get started

Get your Base Station ready to use in a few steps.



After unpacking the Base Station you must update the firmware **before** activating a licence.

**i** If you use LinkDesk the update is mandatory before activating a licence.

## NOTICE



### License activation requires a direct Internet connection to the device

In order to activate the Base Station using the 18-digit license code, a direct Internet connection is required.

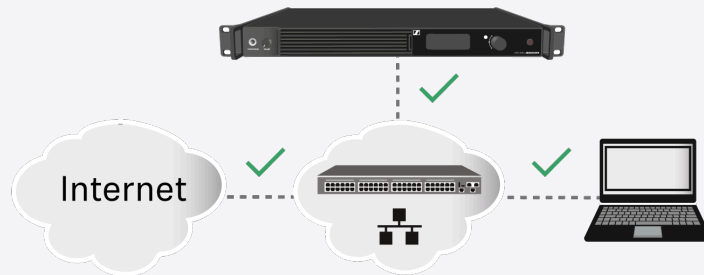

- ▶ Please connect your Base Station directly to a network with Internet access via a switch or router. For more information, refer to the chapter [Connecting to a network](#).
- ▶ Direct connections via laptop etc. are not supported for activation!



- ▶ The Internet is only required once for activation.



To connect the Base Station to the power supply system:

- ▶ Connect one mains cable to the power socket on the rear side of the Base Station.

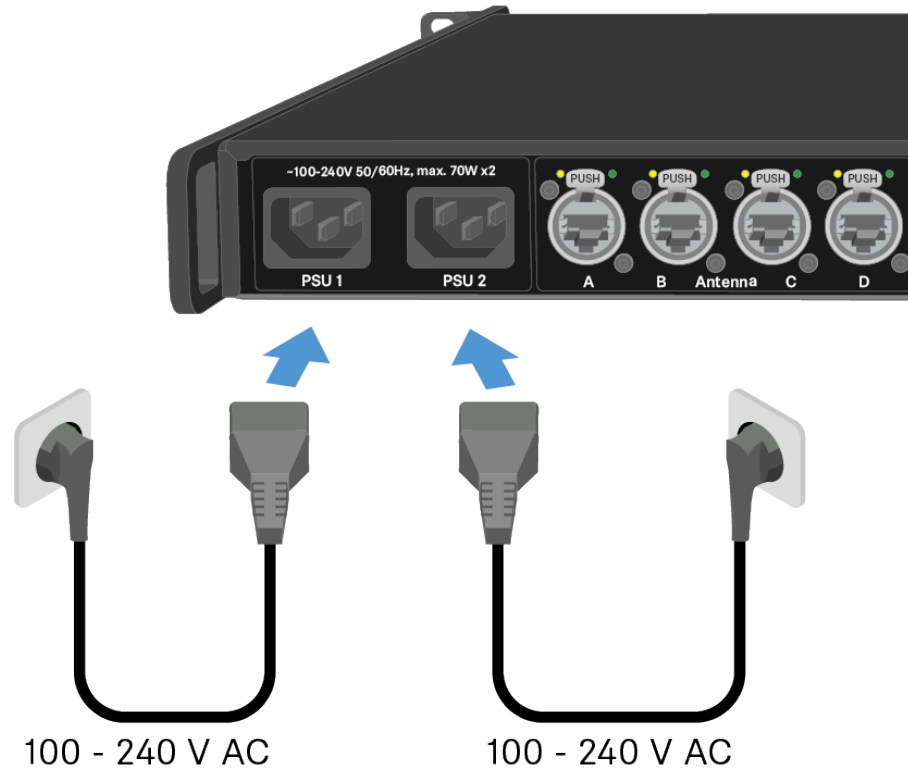

- ▶ Connect one mains cable plug into a suitable wall socket.
  - ✓ The Base Station is connected to the power supply.



**To connect the Base Station to a network:**

- ▶ Plug one side of the network cable into the **Control** socket.

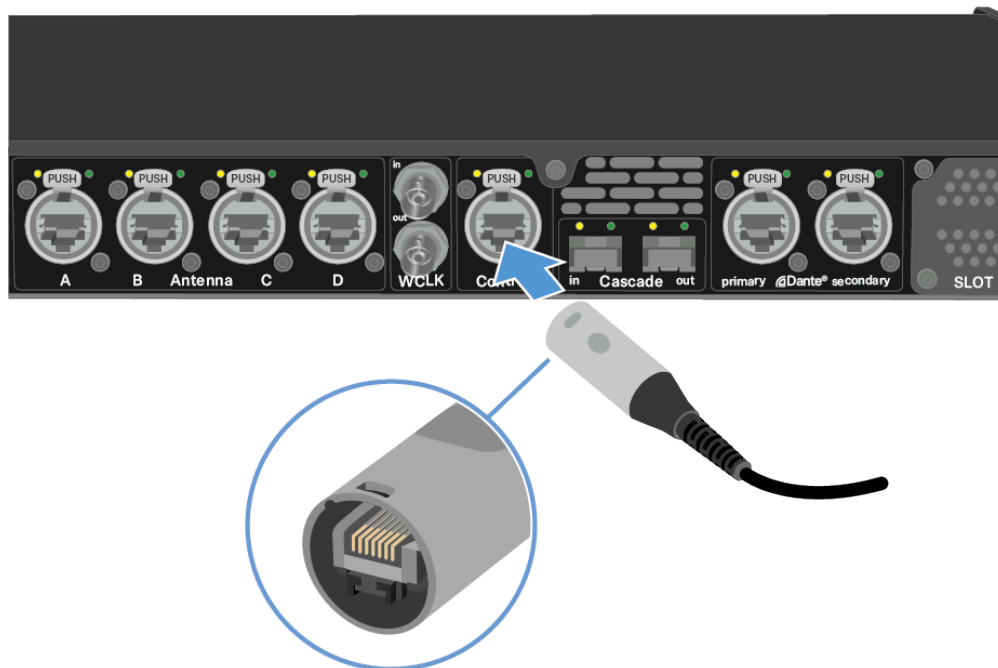

- ▶ Plug the other side of the network cable to a switch, router or directly to a computer.

**i** The Base Station needs a direct Internet access!

- ✓ The Base Station has been connected to a network.

**To update the firmware:**

- ▶ If you want to use Spectera WebUI, it depends on the initial firmware version:
  - Firmware  $\leq$  0.8.x: <https://deviceIP/specteracontrol/index.html> .
  - Firmware  $\geq$  1.x.x: <https://deviceIP/> .

**i** The device IP can be found here: [Network](#).

- ✓ In some cases the internet browser might have trouble showing the page. Please use the LinkDesk software.
- ▶ If you want to use the free LinkDesk software: Download it from the Sennheiser website [sennheiser.com/linkdesk](https://sennheiser.com/linkdesk).  
The update is mandatory before activating a licence.



✓ Your Base Station is up to date.

You can now add a licence, see [Activating a license \(general\)](#).



## General information for the System

Here you can find general information for your use of the System.

**i** A license has to be activated, otherwise you cannot use the Base Station.

The Base Station has two independent RF channels. Both variants of the antenna (UHF and 1G4) can be connected to the Base Station at the same time.

You can pair up to 128 mobile devices to a Base Station within one RF channel.

**i** Mobile devices can only be paired and operated with one Base Station at a time.



## Product overview

### Front



**1 HEADPHONES** socket

see [Using the headphone output](#)

**2 VOLUME** control for headphone

see [Using the headphone output](#)

**3 Fan inlet** with filter

see [Changing the fan filter](#)

**4 Display** for status information and operating menu

see [Information on the display](#)

**5 LED** to indicate the status

see [Meaning of the LED](#)

**6 Jog-Dial (UP/DOWN/SET)** for navigating the menu

see [Navigating the menu](#)

**7 ON/OFF** button

see [Switching the Base Station on and into standby](#)

### Back

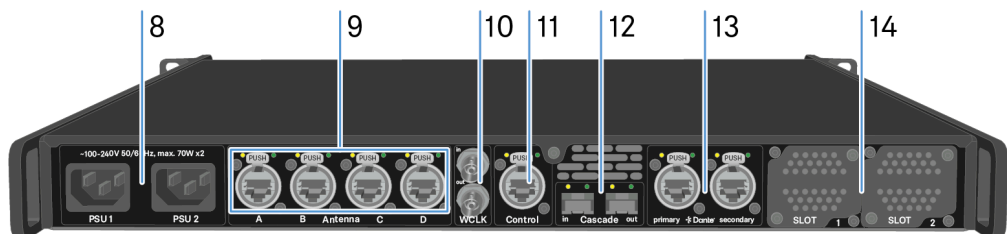

**8 Power socket**

see [Connecting/disconnecting the Base Station to/from the power supply system](#)

**9 4x ruggedized RJ45 Antenna** ports

see [Connecting antennas](#)

**10 Word clock** in/out

see [Connecting word clock](#)



**11** ruggedized RJ45 **Control** port

see [Connecting to a network](#)

**12** Cascade in/out

see [Cascading the Base Stations](#)

**13** 2x ruggedized RJ45 ports for **Dante**<sup>®</sup> primary | secondary

see [Connecting audio via Dante](#)<sup>®</sup>

**14** Slot 1 | 2 for MADI Cards

see [Installing slot-in cards](#)



## Installing slot-in cards

The same or different cards can be installed.

Two types of MADI Cards are available, see [MADI Cards](#).

Madi CARD (BNC)

Madi CARD (OM)

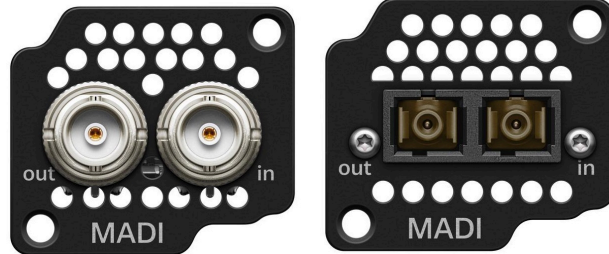

### CAUTION



**Improper handling of the device may result in its damage**

Device contains sensitive electronics to electrostatic discharge (ESD).

- ▶ Observe the precautionary measures for handling components at risk of electrostatic discharge and take appropriate protective measures when touching the device.

### To install a MADI Card in the Base Station:

- ▶ Completely disconnect the Base Station from the power supply system. See [Connecting/disconnecting the Base Station to/from the power supply system](#).
- ▶ Unscrew one of the dummy caps on the Base Station. To do so, you require a torx® 10 screwdriver.

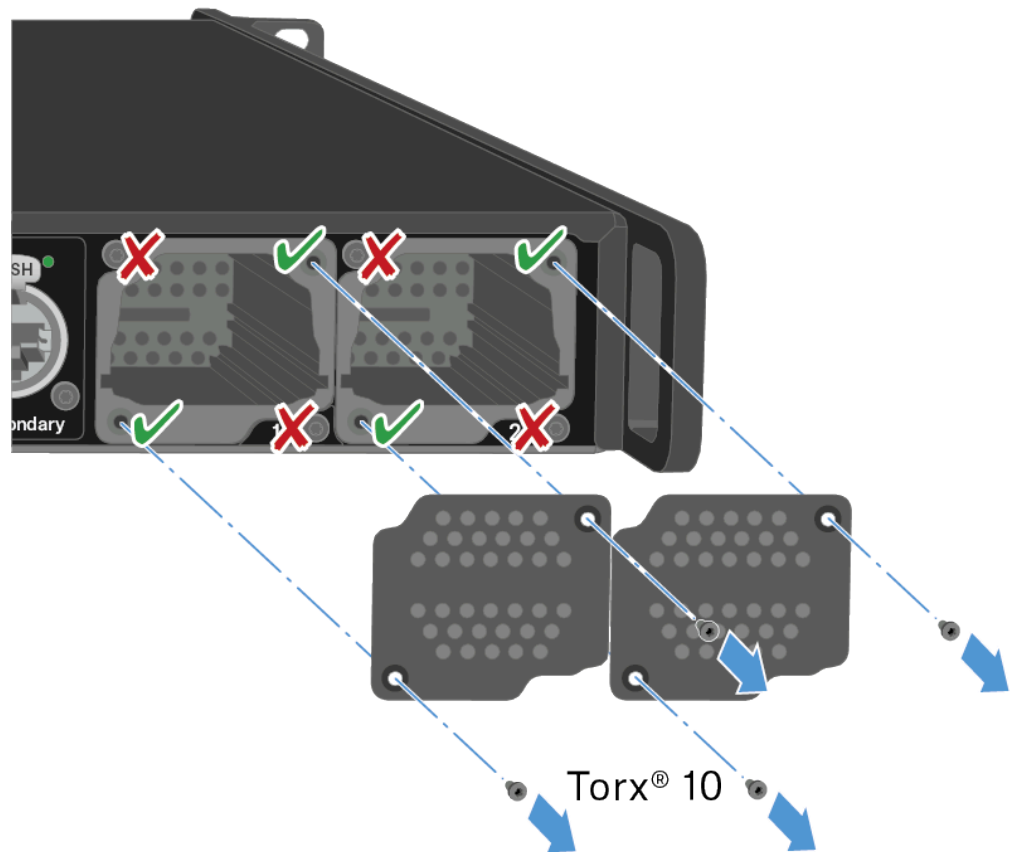

- ▶ Fully slide the MADI Card into the open slot as shown in the figure.
  - ✔ The card can be inserted into the Base Station housing only in one direction. The lettering on the card must face upward.
- ▶ Tightly screw on the MADI card with max. 65 cNm +/-10%.

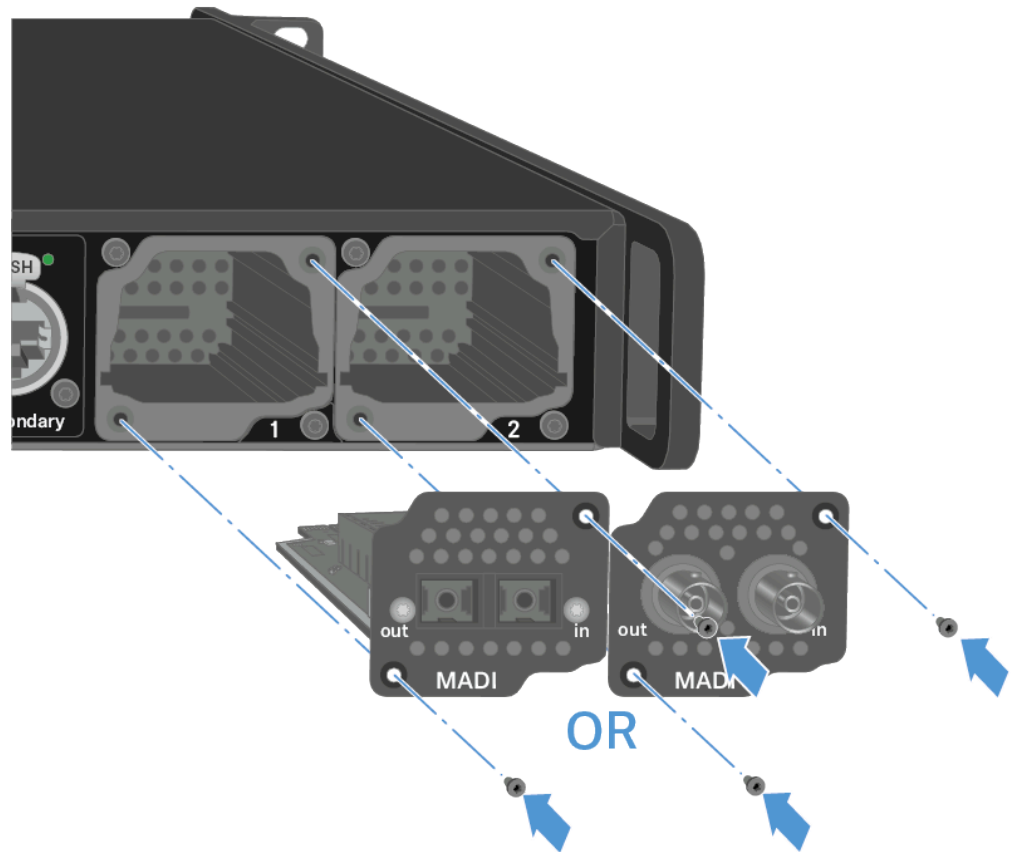

✓ The MADI Cards can be used directly.

✓ A MADI Card has been installed.



## Connecting/disconnecting the Base Station to/from the power supply system

Optional for redundancy you can connect the Base Station with two cables. The optional cable is not included.

### To connect the Base Station to the power supply system:

- ▶ Connect one mains cable to the power socket on the rear side of the Base Station.

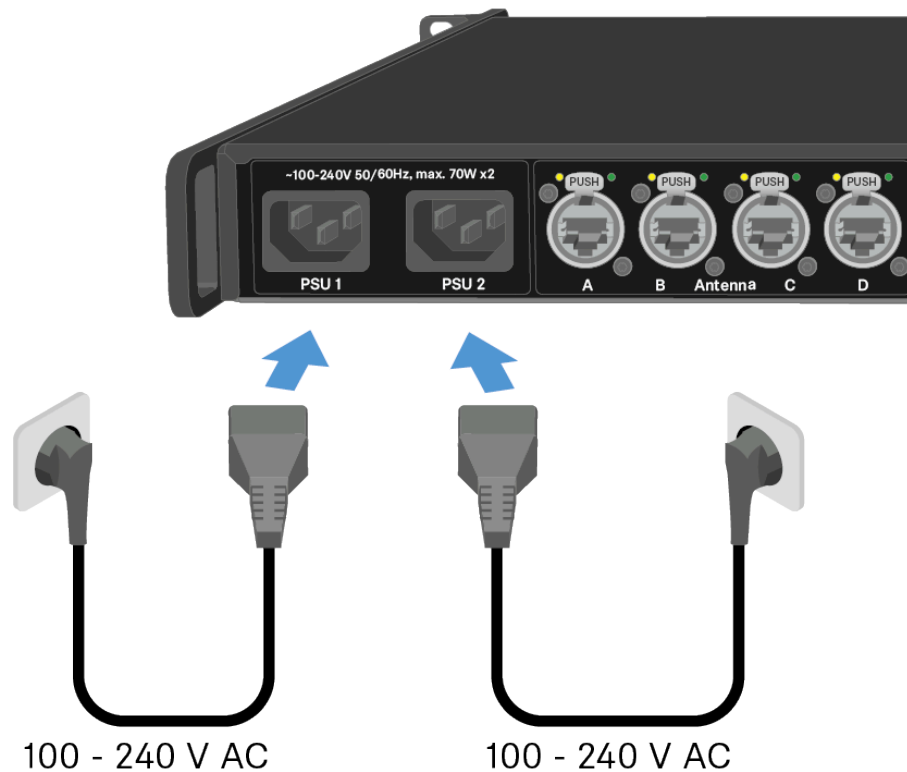

- ▶ Connect one mains cable plug into a suitable wall socket.
  - ✓ The last state is restored: on or standby.
- ▶ For redundancy connect an other cable (not included) as well.
  - ✓ The Base Station is connected to the power supply.

### To completely disconnect the Base Station from the power supply system:

- ▶ Unplug both mains cable plugs from the wall socket.
- ▶ Unplug both mains cable from the power socket on the rear side of the Base Station.
  - ✓ The Base Station is completely disconnected from the power supply.



✓ The Base Station has been connected/disconnected successfully.



## Connecting to a network

Connect the Base Station to a network for monitoring and controlling.

To connect the Base Station to a network:

- ▶ Plug one side of the network cable into the **Control** socket.

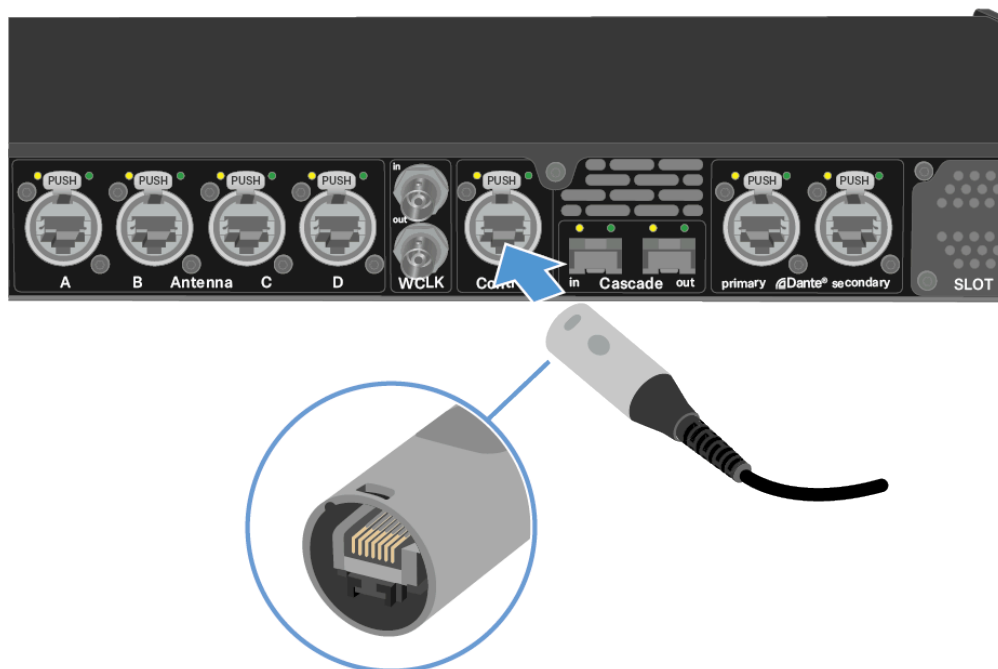

- ▶ Plug the other side of the network cable to a switch, router or directly to a computer.



## NOTICE



### License activation requires a direct Internet connection to the device

In order to activate the Base Station using the 18-digit license code, a direct Internet connection is required.

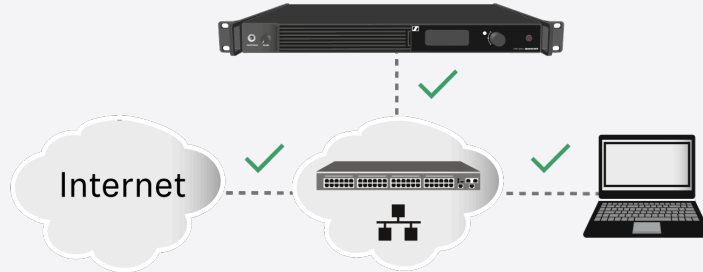

- ▶ Please connect your Base Station directly to a network with Internet access via a switch or router. For more information, refer to the chapter [Connecting to a network](#).
- ▶ Direct connections via laptop etc. are not supported for activation!

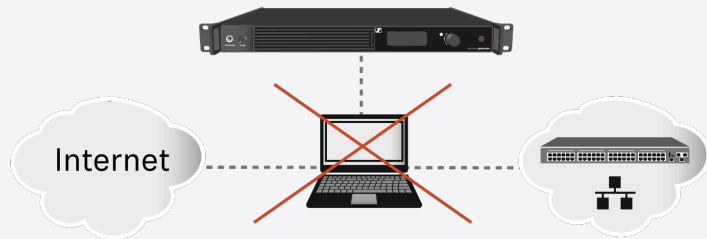

- ▶ The Internet is only required once for activation.

See [Activating a license \(general\)](#).

✓ The Base Station has been connected to a network.

You can monitor and control the Base Station via a network connection using LinkDesk or Spectera WebUI.

LinkDesk is freely available and can be downloaded directly from the Sennheiser website.

- [sennheiser.com/linkdesk](https://sennheiser.com/linkdesk)

To start the Spectera WebUI, enter the following URL into your browser:

- `https://deviceIP`



**i** The device IP can be found here: [Network](#).



## Connecting antennas

You can connect up to four antennas to the Base Station.

Recommendations regarding the antenna setup:

- Keep a distance more than 10 m (393.7") between the antenna and another antenna.
- Keep a distance more than 0.5 m (19.69") between the antenna and a wall.

The cable must

- be a CAT5e or higher,
- have ruggedized plugs and
- not extend 100 m (3937").

**i** We recommend using a antenna cable cat 5e (see [Accessories for the DAD](#)).

**i** Both variants (UHF and 1G4) can be connected to the Base Station at the same time.

### To connect an antenna to the Base Station:

- ▶ Plug one side of the cable into one antenna port (A, B, C or D) at the rear side of the Base Station.
- ▶ Plug the other side of the cable into an antenna.

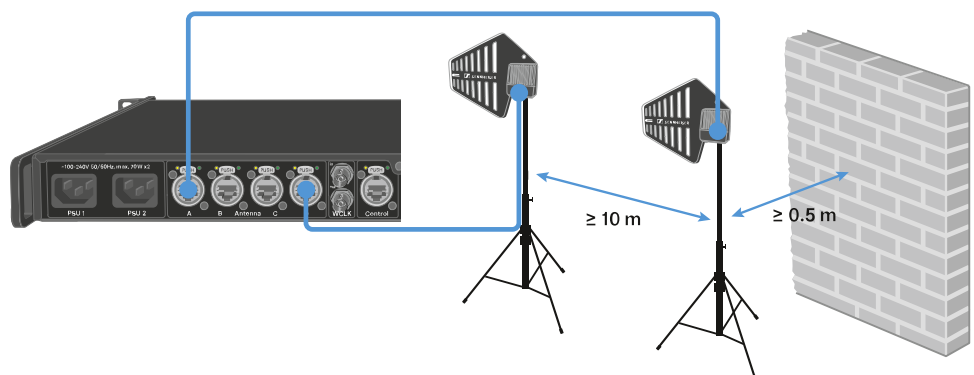

We recommend a distance greater than 10 m (393.7") for an optimal RF performance.

### To disconnect an antenna from the Base Station:

- ▶ Hold down the push button.
- ▶ Unplug the cable from the Base Station.



✓ The Base Station has been connected to/disconnected from an antenna.

## Antenna cable extension

Longer cable distances are possible with the use of fiber optic cables and media converters.

Sennheiser tested the recommend converters for a complete distance of 4 km (157480.31").

We only recommend the following converters for fully tested functionality:

**i** It is mandatory to use the media converters in pairs.

- Lantronix M/GE-PSW-PSE-01 (with PoE for DAD) **or**
- Lantronix M/GE-T-SFP-01 (needs a Class 2 PoE injector capable of supplying powering to the DAD (power consumption < 6.5 W)) **or**
- Barnfind Technologies BarnColor 4xEth (with PoE for DAD) **or**
- ProLabs 10/100/1000Base-TX(RJ-45) to Open SFP Port POE+ Media Converter (C-GMC-SFP-POE+, with PoE for DAD)

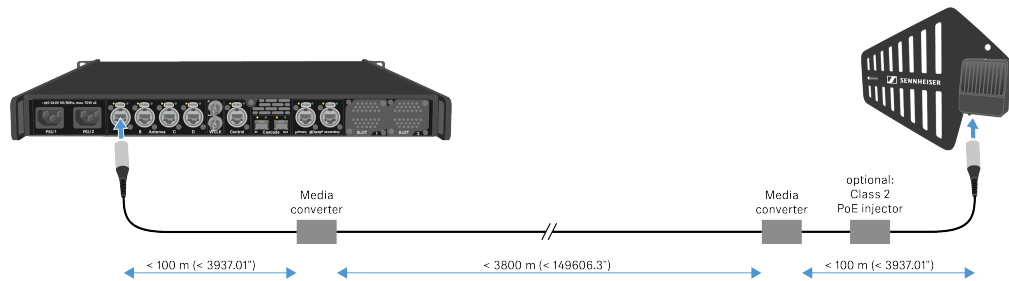

**i** The media converter must not have a switch function.



## Connecting word clock

You can use the internal word clock on the Base Station or connect an external word clock.

You can also output the external word clock and cascade it up to 8 Base Stations.

The word clock output transmits only the external word clock that is connected via the word clock input. The internal word clock is not output via the word clock output.

**i** For more information about the word clock, see [Word clock scenarios for digital audio](#).

### To connect an external word clock:

- ▶ Use a coaxial BNC cable (75  $\Omega$ ) to connect the external word clock to the **word clock in** input.

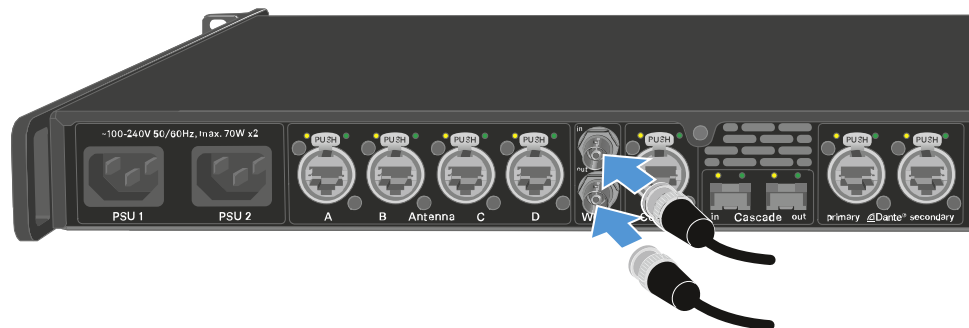



**To cascade the word clock:**

- ▶ Connect the cable from the **word clock in** input of the next Base Station to the **word clock out** output of the previous Base Station.

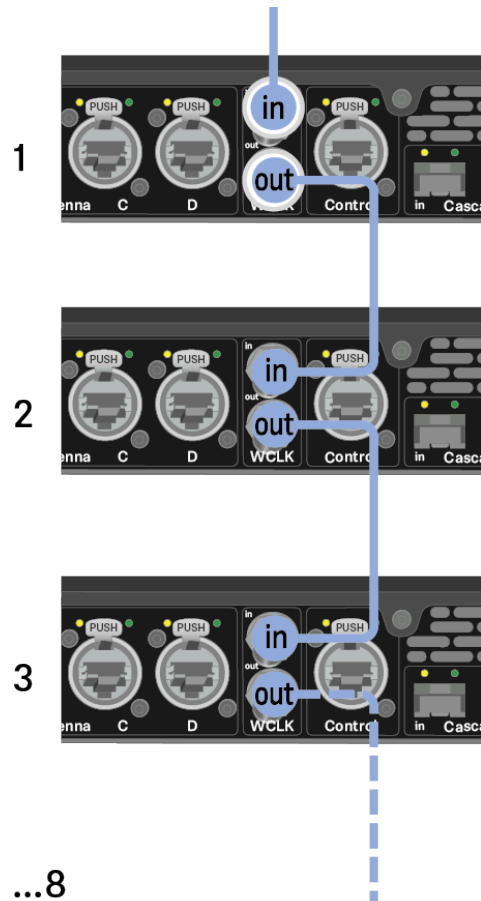

✓ The Base Station has been connected to word clock.

## Word clock scenarios for digital audio

The Base Station supports two clock rates: 48 kHz and 96 kHz.

You can use either the internal word clock on the Base Station or connect an external word clock.

An external word clock can also be forwarded to a downstream device via the word clock output. This feature allows you to cascade up to 8 Base Station devices.

**i** Note that only the word clock on the word clock input can be forwarded via the word clock output. The internal word clock is not forwarded via the word clock output.



### Word clock with digital audio

If multiple devices with digital audio signals are connected in a production environment, their clock signals must be synchronized via a word clock, otherwise audio errors occur. The word clock of one device becomes the master. All of the other devices become slaves and synchronize with the master.

#### Dante®

The Audinate Brooklyn III Dante® interface installed in the Base Station should be understood as a standalone digital audio device with its own word clock and also has to be clocked either internally or externally.

**i** You require the Dante Controller software from Audinate for these settings. You can access it using the link: [Dante Controller](#).

### Defining the master and slave

The Base Station word clock input, the Base Station internal word clock, the word clock of the Audinate Brooklyn III Dante® interface, or the Dante® network can be defined as the master.

For LinkDesk see: [Configuring interface settings](#).

For WebUI see: [Audio interfaces](#).



## Connecting audio via Dante®

You can input and output audio via Dante®.

To connect audio via Dante®:

- ▶ Plug one side of a ruggedized RJ45 cable to the Dante® primary socket.

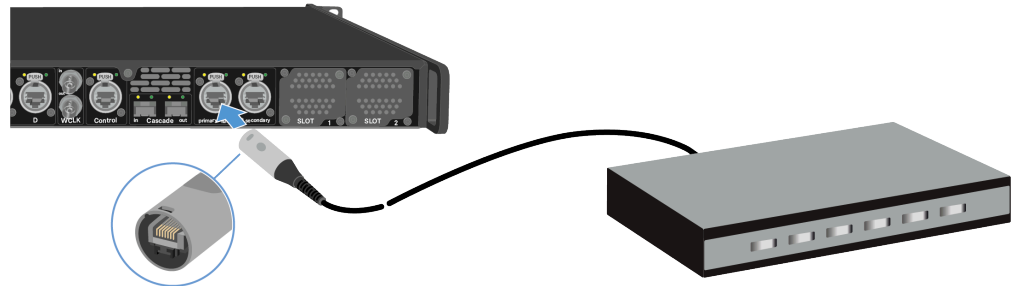

- ▶ Plug the other side into a router.
- ▶ Download the Dante® Controller.  
This is typically a host computer (PC or Mac), with the Dante® Controller software application installed. This application configures and controls all the Dante® devices and audio streams inside the network.

**i** Information about the Dante Controller and the Dante® network protocol settings is available on the Audinate website: [audinate.com](https://audinate.com).

✓ The Base Station can input and output audio via Dante®.

### Shared network mode

In Shared Network Mode both networks for Control and Dante® are using the same physical network infrastructure.

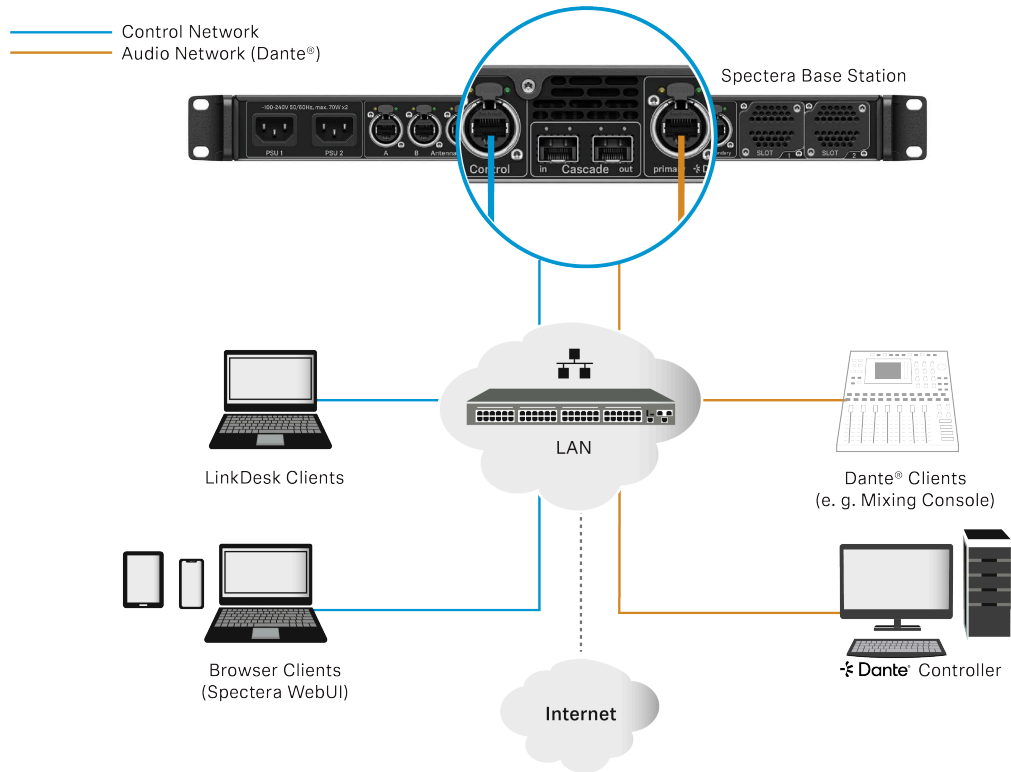

### Split Network Mode

In Split Network Mode both networks for Control and Dante® are using different physical network infrastructure.

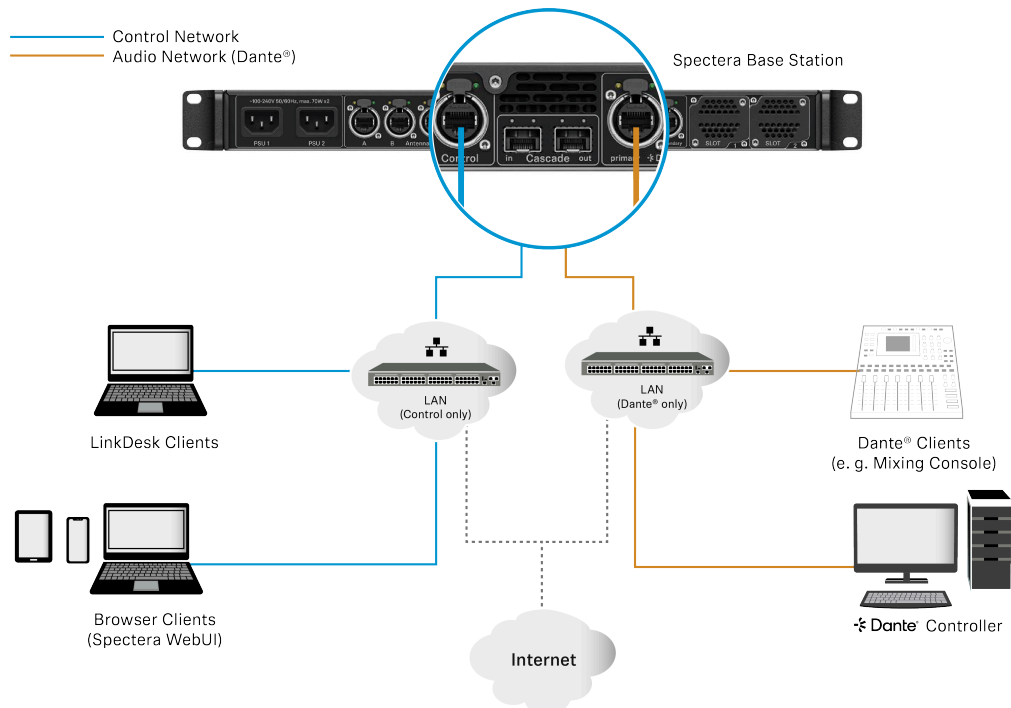



**i** For more information, please refer to the Network & Security Guide, which can be found in the download section on the Base Station product page [sennheiser.com/base-station](https://sennheiser.com/base-station).



## Connecting audio via MADI

To connect audio via MADI:

- ▶ Plug one side of the (BNC or OM) cable to the installed MADI card.

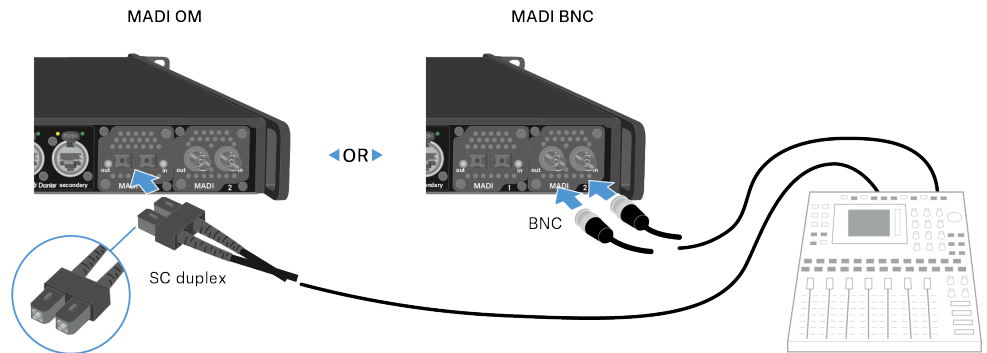

- ▶ Plug the other side of the cable to a mixing console.

✓ The Base Station can input and output audio via MADI.



## Changing the fan filter

The filter protects the fans from dust.

- i** Check the filter from time to time and replace it to ensure safe operation and sufficient cooling.

### To change the filter:

- ▶ Switch the Base Station into standby. See [Switching the Base Station on and into standby](#).
- ▶ Push down the release and pull the cover forward at the same time.

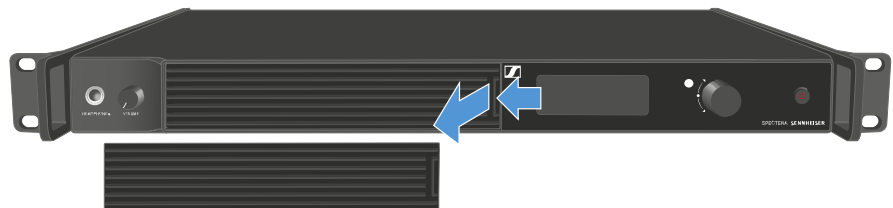

- ▶ Remove the filter and dispose it properly.
- ▶ Place a new filter in the Base Station.  
Information about new filter can be found here: [Spectera Filter set](#).
- ▶ Make sure that the recesses match those in the device.

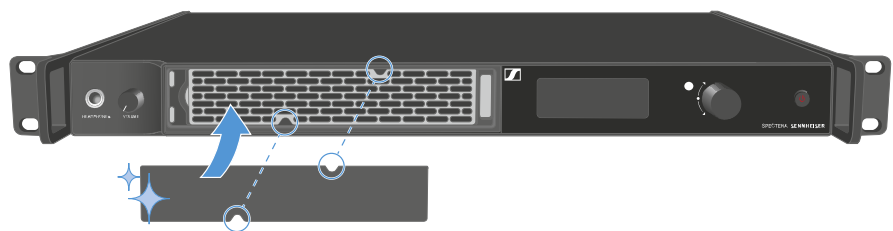

- ▶ Slide the cover into the left side.





- ▶ On the right side, press the cover firmly until you hear it click into place.



✓ The filter has been replaced.



## Installing the Base Station in a rack

You can install the Base Station in any conventional 19" rack. The rack mounting angles are already attached to the device.

Always observe the following information during rack mounting.

### NOTICE



#### Material damages caused by devices overheating

When there is insufficient ventilation, the devices mounted in the rack may overheat.

- ▶ Ensure that there is sufficient ventilation in the rack, particularly if several devices are installed.
- ▶ If necessary, install a fan in the rack.

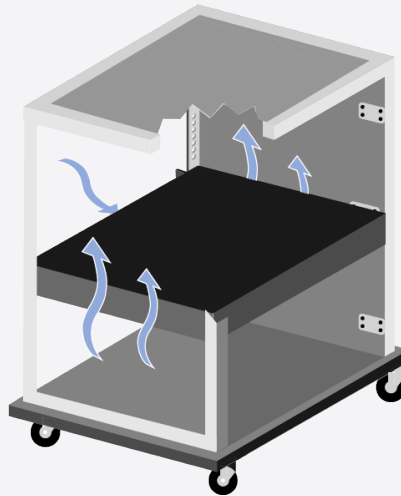

- ▶ Support the Base Station after installation in the rack.

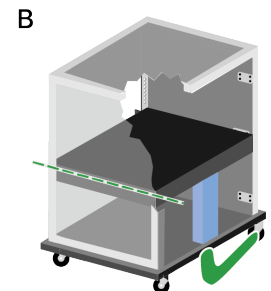
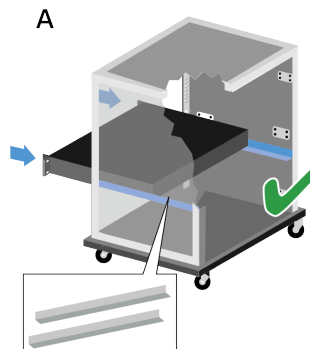
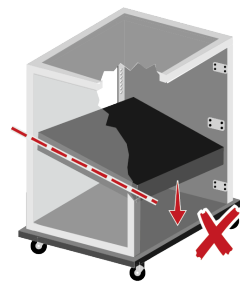

Due to the weight and depth of the device, there is a risk that it may break off in the rack and become damaged as a result.



**Version A**

- ▶ Use special rack mounting rails.
- ▶ The design of the rack used must be suitable for the installation of these mounting rails.

**Version B**

- ▶ Use a suitable object to support the device on the rear side.
- ▶ Ensure that this object cannot become loose.

✓ The Base Station has been installed in a rack.



## Switching the Base Station on and into standby

- i** The Base Station cannot be switched off. You have to disconnect it from the power supply, see [Connecting/disconnecting the Base Station to/from the power supply system](#).

### To switch the Base Station on:

- ▶ Short-press the **ON/OFF** button.
  - ✓ The Sennheiser Logo appears in the display and the Base Station is booting. When booting is done, the power button LED lights up white.

### To switch the Base Station into standby:

- ▶ Long-press the **ON/OFF** button.
    - ✓ The display and the LED go off. The **ON/OFF** button pulses white.
- The DAD goes off.

- ✓ The Base Station has been switched on/into standby.



## Activating a license (general)

**i** A license has to be activated, otherwise you cannot use the Base Station.

### NOTICE



#### License activation requires a direct Internet connection to the device

In order to activate the Base Station using the 18-digit license code, a direct Internet connection is required.

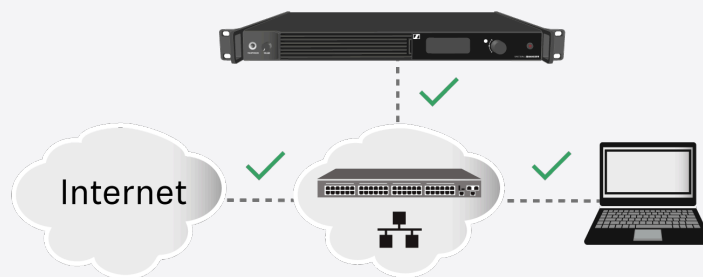

- ▶ Please connect your Base Station directly to a network with Internet access via a switch or router. For more information, refer to the chapter [Connecting to a network](#).
- ▶ Direct connections via laptop etc. are not supported for activation!

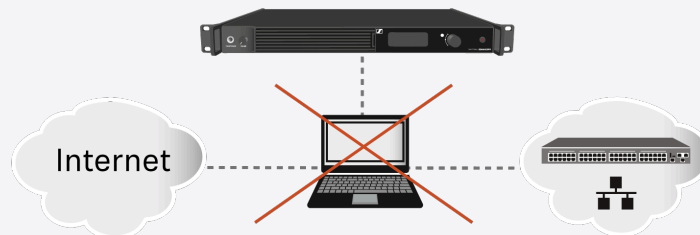

- ▶ The Internet is only required once for activation.

The license specifies the country-specific frequency ranges and the RF power.

You can activate a license via LinkDesk or Spectera WebUI.

Only one license per Base Station is possible.

#### To activate a license:

- ▶ Connect the Base Station to the power supply, see [Connecting/disconnecting the Base Station to/from the power supply system](#).
- ▶ Connect the Base Station to a network via a switch or router, see [Connecting to a network](#).



**i** The Base Station needs a direct Internet access!

- ▶ Connect a computer to the same switch or router.
- ▶ If you want to activate a license via LinkDesk, follow the steps described here: [Activating a license \(LinkDesk\)](#).
- ▶ If you want to activate a license via Spectera WebUI, follow the steps described here: [Activating a license \(WebUI\)](#).
- ▶ Check the product page [sennheiser.com/base-station](https://sennheiser.com/base-station) for the latest firmware.

✓ A license has been activated.



## Using the headphone output

You can use the headphone output on the front of the Base Station (6.35 mm jack) to listen to the audio signals of the channels.

**i** First you have to set up audio links in LinkDesk or Spectera WebUI.

### WARNING



#### Danger due to high volume levels

Volume levels that are too high may damage your hearing.

- ▶ Turn down the volume of the headphone output before you put on the headphone.

#### To listen to an audio source:

- ▶ Connect the headphone to the **HEADPHONES** socket.

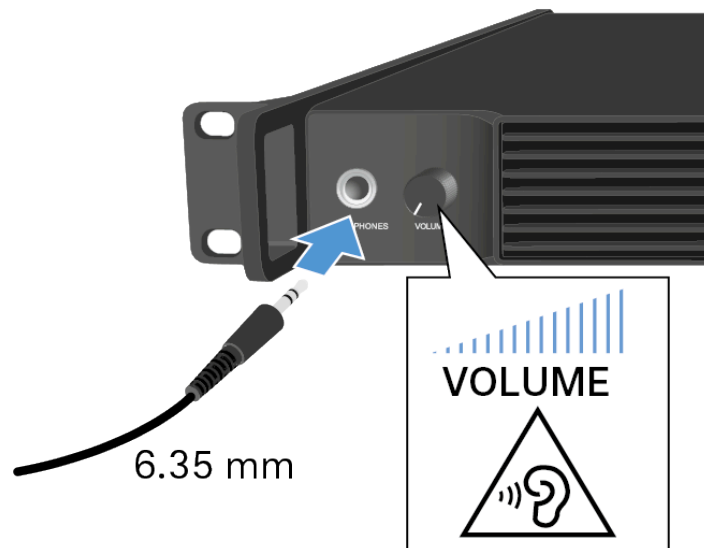

- ▶ You can select the audio source here: [Headphone](#).
- ▶ Control the volume by turning the **VOLUME** control next to the **HEADPHONES** socket.

✓ You can now listen to the selected audio source.



## Meaning of the LED

The LED on the front of the Base Station indicates the following information.



The LED is off:

- Base Station is in standby.



The LED is green:

- Base Station is on and one or both RF channels are active.



The LED is yellow:

- One or both RF channels are muted.

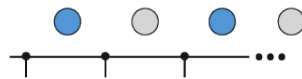

The LED is flashing blue:

- Paring is enabled.

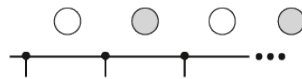

The LED is flashing white:

- The Base Station is identified.

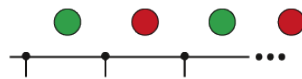

The LED is flashing green and red:

- Firmware update is in progress.



The LED is red:

- Base Station is working, but shows a warning on the display.

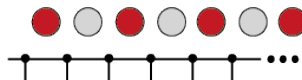

The LED is flashing red quickly:

- Error. Base Station is not working and shows a warning on the display.



## Information on the display

Basic information are shown on the display.

The display goes into screen saver after some time.

You can wake up the display by pressing or turning the jog-dial.

The display shows the operating menu, which can be used to configure a few settings (see [Menu structure](#)).

**i** More options and other parameters are available in LinkDesk and Spectera WebUI!

To navigate the menu, see [Navigating the menu](#).

Status messages

In certain situations, status messages may appear on the display.

**Critical Temperature -  
Audio processing stopped  
Please cool down Base Station!**

**Error** - The temperature is critical. The audio processing stopped. Cool down the Base Station.

**High Temperature -  
Check ventilation to  
avoid audio interruption**

**Warning** - The temperature is high. Check the ventilation to avoid audio interruption.

**Heating up Base Station  
Please stand by**

**Warning** - The temperature is low. The Base Station is heating up. Please stand by.



## Navigating the menu

Use the jog-dial to navigate through the operating menu.



**Press** the jog dial



- Calls up a menu item
- Changes to a submenu
- Saves settings

**Turn** the jog dial



- Changes to the previous or next menu item
- Changes the setting of a menu item



## Menu structure

In the Base Station menu, you can configure a few settings.

**i** More options and other parameters are available in LinkDesk and Spectera WebUI!

The following settings can be changed:

### Mute/Unmute the RF-Channels

- [Main menu](#)

### Change the IP mode

- [Network](#)

### Select the audio source for the headphone

- [Headphone](#)

### Reset the Base Station

- [Reset](#)

## Main menu

In this menu item, you can view information about connections.

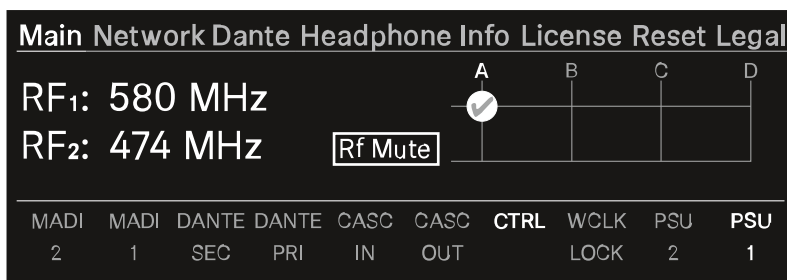

In the upper part you can view information about the RF channel:

- The selected frequency
- The state of the antenna (mute, active)
- Which antenna port is used for the RF channel.

In the lower part you can view information about the used connection:

- Connected ports are highlighted.
- The order corresponds to the ports on the back.



**To mute/unmute the RF channel:**

- ▶ Press the jog-dial.
- ✓ The RF Status menu opens.

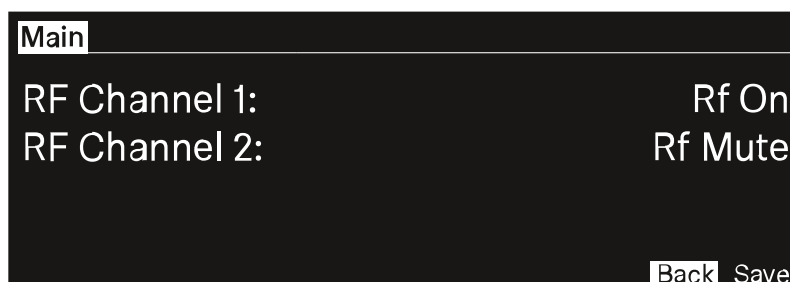

- ▶ Rotate and press the jog-dial to change the settings.  
You can select between Rf on and Rf Mute.
- ▶ Confirm by selecting Save or discard the changes by selecting Back.

- ✓ The RF Channels have been muted/unmuted.



## Network

In this menu item, you can configure the settings for the network connection.

|  |             |
|--|-------------|
| <b>Main Network Dante Headphone Info License Reset Legal</b> |             |
| IP Mode  | AutoIp/mDNS |
| IP Addr  | 169.254.1.1 |
| Netmask  | 255.255.0.0 |
| Gateway  | 0.0.0.0     |

You can make the following settings here:

### IP Mode

- Manual
  - You can change the IP Address, the Netmask and the Gateway.
- Manual/mDNS
  - You can change the IP Address, the Netmask and the Gateway.
- AutoIp
  - You can **not** change the IP Address, the Netmask and the Gateway.
- AutoIp/mDNS
  - You can **not** change the IP Address, the Netmask and the Gateway.



## Dante

In this menu item, you can view information about the two Dante® connections.

|  |             |
|--|-------------|
| <u>Main Network Dante Headphone Info License Reset Legal</u> |             |
| Sampling rate  | 48 kHz      |
| Primary  | Autolp/mDNS |
| Secondary  | Autolp/mDNS |
| Status   | connected   |

The following information are displayed:

- Sampling rate
- IP mode for Primary
- IP mode for Secondary
- Status

### To display a Dante® connection:

- ▶ Press the jog-dial to change the Dante® connection.
- ▶ Rotate the jog-dial to change between Primary and Secondary.

| Dante   |                 |
|---------|-----------------|
| Primary | Secondary       |
| IP Addr | XX.XX.XX.XX     |
| Netmask | XXX.XXX.XXX.XXX |
| Gateway | XX.XX.XX.X      |

- ▶ Press the jog-dial to enter the setting.

✓ The selected Dante® connection is displayed.



## Headphone

In this menu item, you can select the headphone output.

You have to set up audio links via LinkDesk or Spectera WebUI for the mobile devices.

If no audio link is set this note will appear:

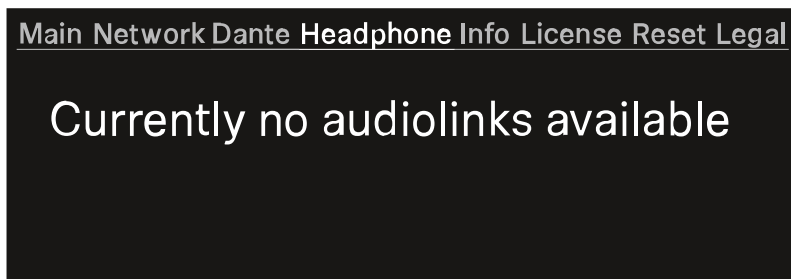

**i** First you have to set up audio links in LinkDesk or Spectera WebUI.

### To select an audio link:

- ▶ Press the jog-dial to enter the headphone menu.  
Each audio output will be shown independent.
- ✓ The created audio links appear.

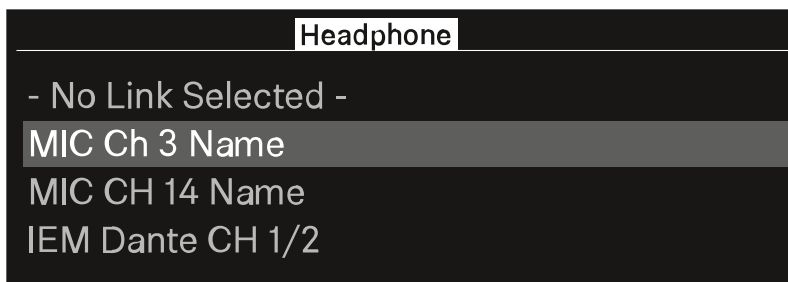

- ▶ Turn the jog-dial to select the wanted audio link.
- ✓ The name of the selected link pulses two times.

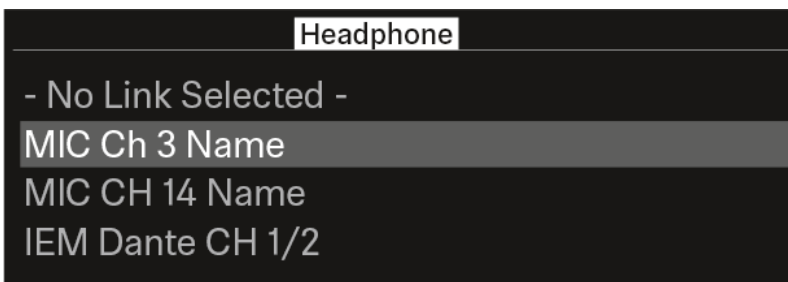

- ▶ Press the jog-dial to return to the main menu.



- ✓ The selected link appears.

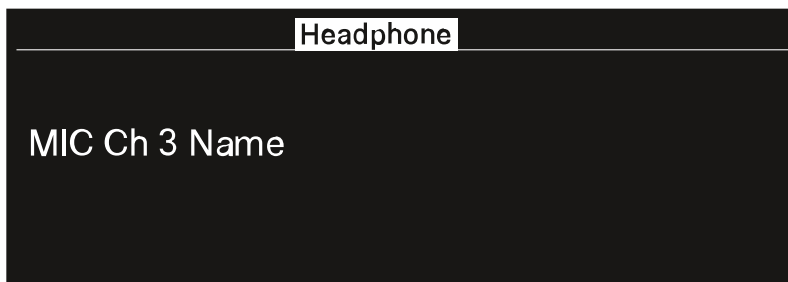

- ✓ You can now listen to the selected audio link.



## Info

In this menu item, general information can be shown here.

|  |                  |
|--|------------------|
| Main Network Dante Headphone <b>Info</b> License Reset Legal |                  |
| Name   | BaseStation Name |
| Serial   | XXXXXXXXXX       |
| Firmware   | vX.X.X           |

**Name:** The name of the Base Station.

**Serial:** The serial number of the Base Station.

**Firmware:** The installed firmware version.



## License

In this menu item, information about the license can be shown here.

**i** A license has to be activated, otherwise you cannot use the Base Station.

You can activate a license via LinkDesk or Spectera WebUI.

Only one license per Base Station is possible.

The license specifies the country-specific frequency ranges and the RF power.

### No license is activated:

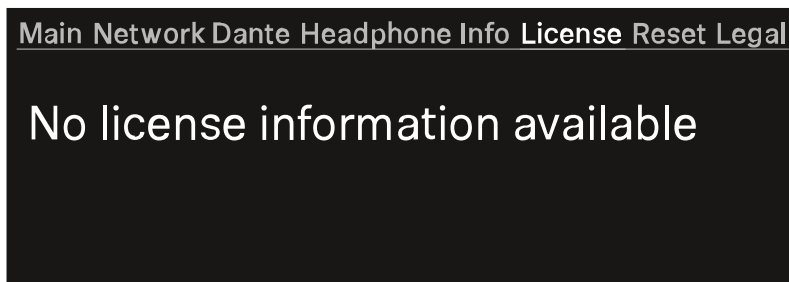

### A license is activated

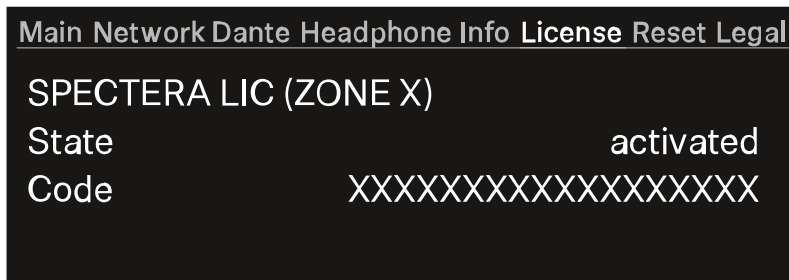

### Name of the purchased license:

- Spectera LIC (ZONE 01)
- ...
- Spectera LIC (ZONE XX)

### State: Status of the license.

- activated
- unknown

### Code:

- The activated license number has 18 digits.
- n/a



## Reset

In this menu item, you can reset the Base Station to its factory settings.

### NOTICE



#### Data loss during the factory reset

All audio devices will be unpaired and all audio routes will be deleted.

All settings (including the device password) are reset to the default values. The license remains activated.

After the reset, the device is restarted automatically.

- ▶ Do not reset the Base Station during an active live audio transmission.

[Main](#) [Network](#) [Dante](#) [Headphone](#) [Info](#) [License](#) [Reset](#) [Legal](#)

Press to reset Base Station

To reset the Base Station to its factory default settings using the device:

- ▶ On the Base Station, rotate the jog-dial and navigate to the menu **Reset**.
- ▶ Press the jog-dial to enter the menu.
  - ✓ A warning will appear.

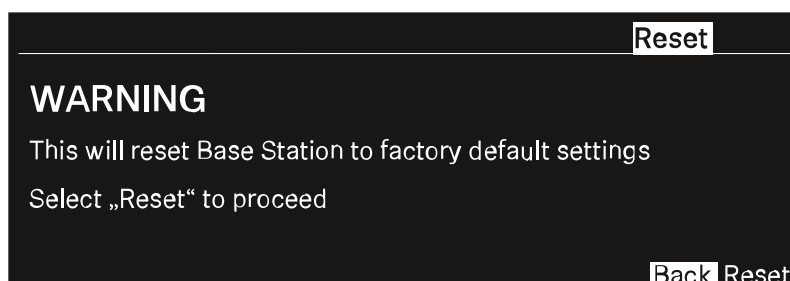

- ▶ Rotate the jog-dial to **Reset**.
- ▶ Press the jog-dial again.



- ✓ The Base Station will be set back to factory settings and reboot.

**i** After rebooting, check the IP address as it may have changed.

- ✓ The Base Station has been reset to its factory default settings.



## Legal

In this menu item, legal information can be shown.

Legal information about the Base Station and connected antennas are displayed depending on the activated license.

If no label are available, the display shows:

Main Network Dante Headphone Info License Reset **Legal**

No legal information available



## Updating the Base Station

You can update the firmware of the Base Station via LinkDesk or Spectera WebUI.

All Spectera devices must use the same firmware. The Base Station determines the firmware version.

Please note that firmware versions are not backward compatible.

### NOTICE



#### Data loss during firmware update

The audio transmission is interrupted during the firmware update of the Base Station, the antenna or the mobile device.

After the firmware update, the device is restarted automatically.

- ▶ Do not update the firmware during an active live audio transmission.

#### To update the firmware:

- ▶ If you want to update the Base Station via LinkDesk, follow the steps described here: [Updating the firmware \(Base Station\)](#).
  - ✓ The LED is flashing green and red during the update.
- ▶ If you want to update the Base Station via Spectera WebUI, follow the steps described here: [Updating the firmware \(Base Station\)](#).
  - ✓ The LED is flashing green and red during the update.

When the update is installed, the Base Station restarts.

The update will be installed on the connected antennas automatically.

✓ The firmware has been updated.

The new firmware is distributed to the other devices via the Base Station.



SEK

## Product overview

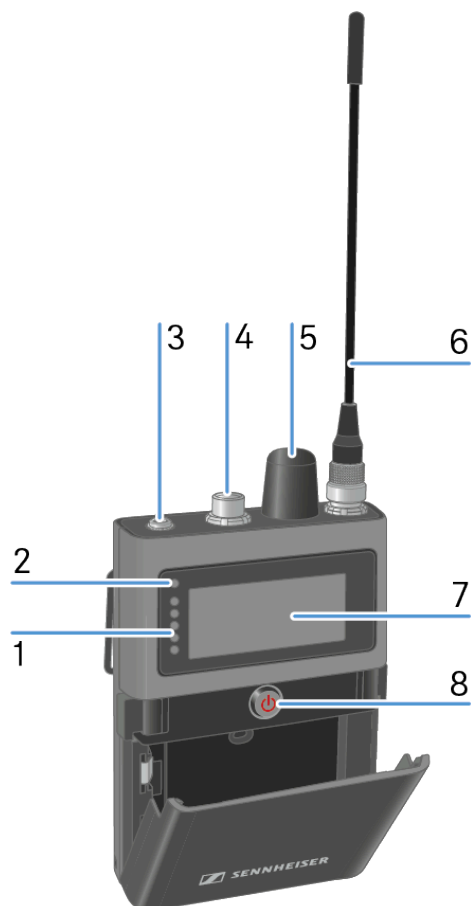

1 LEDs

see [Meaning of the LEDs](#)

2 Status LED

see [Meaning of the LEDs](#)

3 Phones 3.5 mm jack

see [The Phones jack uses](#)

4 Microphone / Instrument input

see [Connecting a microphone / instrument](#)

5 Rotary encoder

with push function

see [Information on the display](#)

6 Antenna

see [Mounting the antenna](#)



**7** Display

see [Information on the display](#)

**8** ON/OFF Button

see [Switching the SEK on and off](#)



## Inserting and removing the rechargeable battery

The SEK operates only with the rechargeable battery BA 70 (separate accessory).

**i** The BA 70 can be charged in the L 70 USB, the L 6000 with LM 6070 or with the SEK in the CHG 70N-C. See

- L 70 USB: [Charging the rechargeable battery](#)
- L 6000: [Charging the rechargeable batteries in the L 6000 charger](#)
- CHG 70N-C: [Charging the rechargeable battery](#)

### To insert the rechargeable battery into the SEK:

- ▶ Press the two catches and open the battery compartment cover.



- ▶ Insert the BA 70 rechargeable battery in the battery compartment.



- ▶ Close the battery compartment.



- ✓ The cover locks into place with an audible click.



✓ The battery has been inserted.



## Mounting the antenna

Two antennas are available, one for each frequency range.

For more information see [Spectera SEK Antenna](#).

The antenna is screwed on when it is delivered.

### To mount the antenna to the SEK:

- ▶ Connect the antenna to the SEK antenna socket.
- ▶ Tightly screw the antenna coupling ring onto the SEK antenna socket.

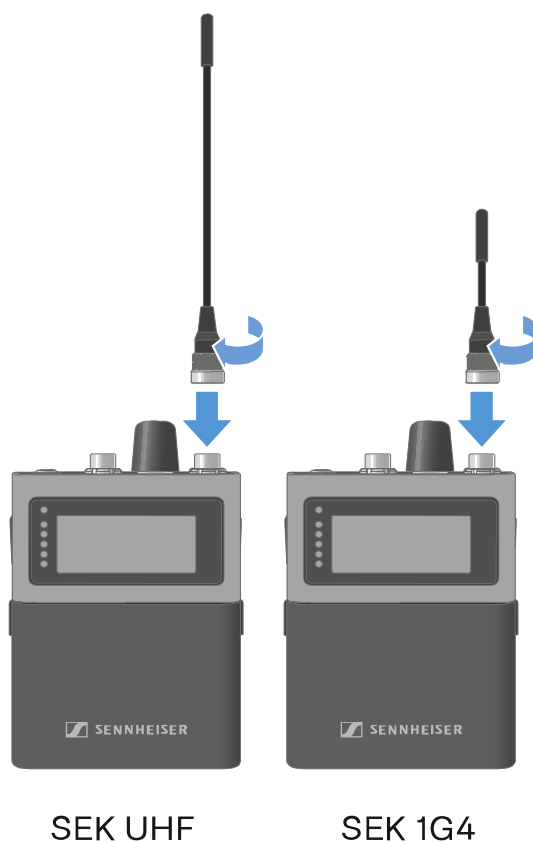

✓ The antenna has been mounted.



## Using the protection cap

The cap protects the microphone / instrument input, when not in use.

**To screw the cap on the SEK:**

- ▶ Screw the cap on the microphone / instrument input socket.

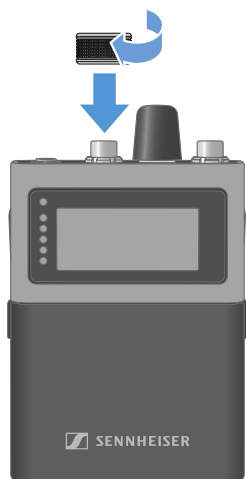

✓ The cap has been attached.



## Connecting a microphone / instrument

You can connect a microphone or instrument to the SEK.

**To connect a microphone to the SEK:**

- ▶ Use a 3-pin audio connector to connect the microphone cable to the SEK microphone / instrument input socket.
- ▶ Screw the plug's coupling ring onto the microphone / instrument input thread of the SEK.

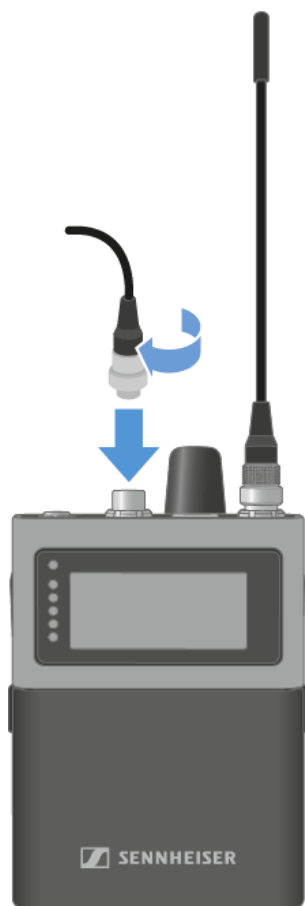



**To connect a instrument to the SEK:**

- ▶ Use a 3-pin audio connector to connect the instrument cable to the SEK microphone / instrument input socket.
- ▶ Screw the plug's coupling ring onto the microphone / instrument input thread of the SEK.

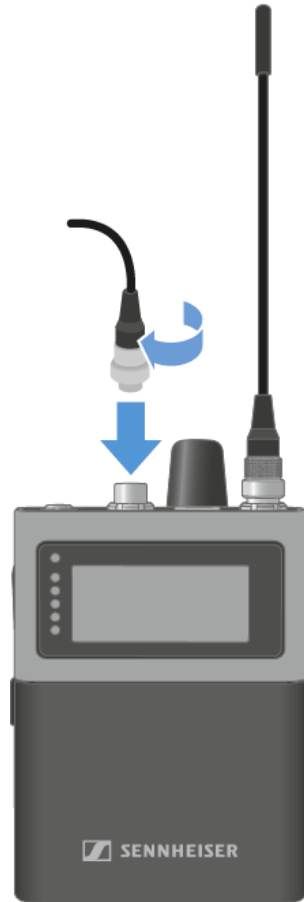

✓ A microphone or instrument has been connected.

**i** The automatic mic/line detection is based on power consumption and is optimized for use with Sennheiser microphones. Because third-party microphones vary widely, reliable detection cannot always be ensured. To select the auto input manually, see **Selecting the Mic/Line input**.

The following microphones are compatible:

- **Headmic 1 (3-Pin)** | Headset microphone with omni-directional pattern
- **Headmic 4 (3-Pin)** | Headset microphone with cardioid pattern
- **HM 200 (3-Pin)** | Headset microphone with omni-directional pattern
- **HSP 2 (3-Pin)** | Headset microphone with omni-directional pattern



- **HSP 4 (3-Pin)** | Headset microphone with cardioid pattern
- **ME 102 (3-Pin)** | Mini-microphone with omni-directional pattern
- **MKE 1 (3-Pin)** | Lavalier microphone with omni-directional pattern
- **MKE 2 (3-Pin) blue label** | Lavalier microphone with omni-directional pattern
- **MKE 40 (3-Pin)** | Lavalier microphone with cardioid pattern
- **MKE Essential (3-Pin)** | Lavalier microphone with omni-directional pattern



## The Phones jack uses

**i** You have to set up an audio link in LinkDesk or Spectera WebUI.

### CAUTION



#### Danger due to high volume levels

Volume levels that are too high may damage your hearing.

- ▶ Turn down the volume of the headphone output before you put on the headphone.

The SEK checks the headphone's impedance when a headphone is plugged in at switching on, or each time a headphone is newly plugged in.

### To connect earphones to the SEK:

- ▶ Turn down the volume.

**i** The volume can be altered between -100 dB to +27.5 dB in steps of 0.5 dB.

- ▶ Insert the cable's 3.5 mm jack plug into the phones socket on the SEK.

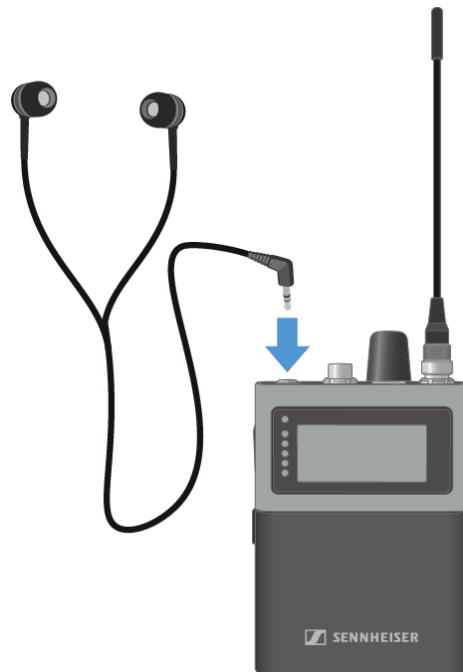



**To connect an adapter cable:**

- ▶ Insert the 3.5 mm jack plug of the cable into the **Phones** jack on the SEK.
- ▶ Connect the other plug to the desired device.
- ▶ In the WebUI, set the **Phones Output** to **Balanced**, see [Selecting the phones output](#). The **Balanced** setting can only be used with mono Link Modes.

✓ The **Phones** jack is used.



## Changing the belt clip

You can change the belt clip on the SEK or flip it over depending on how you want to wear it.

### To remove the belt clip:

- ▶ Hold down the belt clip with the thumb to the housing.
- ▶ Use the other hand to carefully pull back and then out one side of the belt clip.

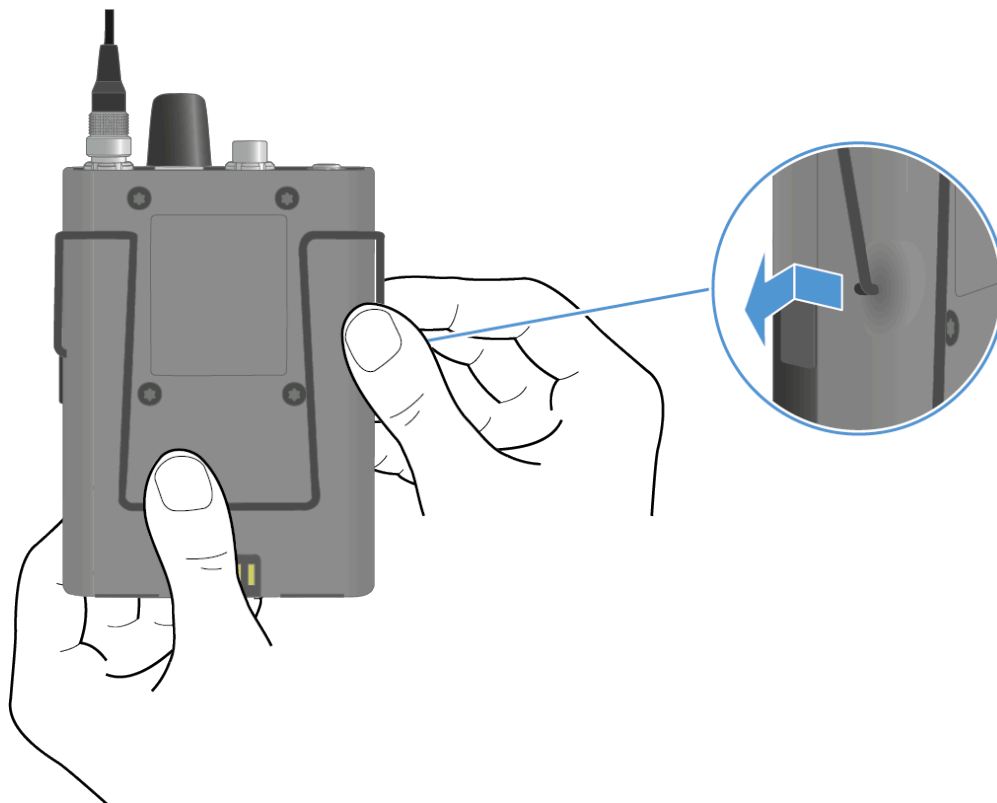



- ▶ While still holding the belt clip down, carefully pull back and then out the other side of the belt clip.

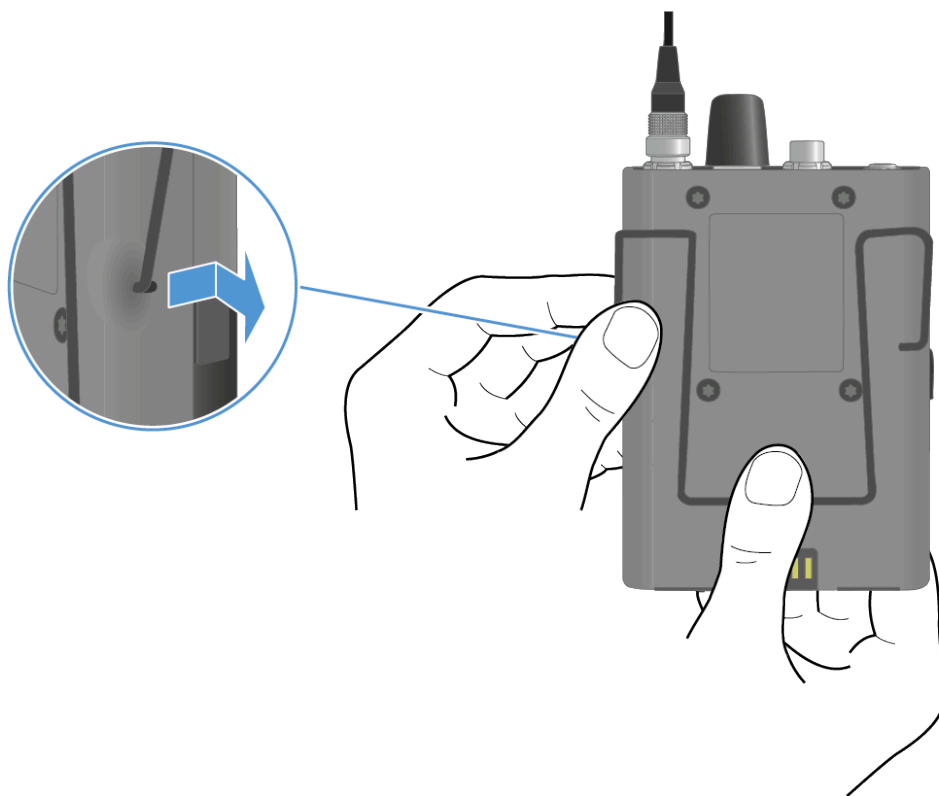

**To insert the belt clip:**

**i** Always insert one side before the other, not at the same time, as otherwise the belt clip could bend.

- ▶ Hold down the belt clip with the thumb to the housing.
- ▶ Insert one side of the belt clip first.

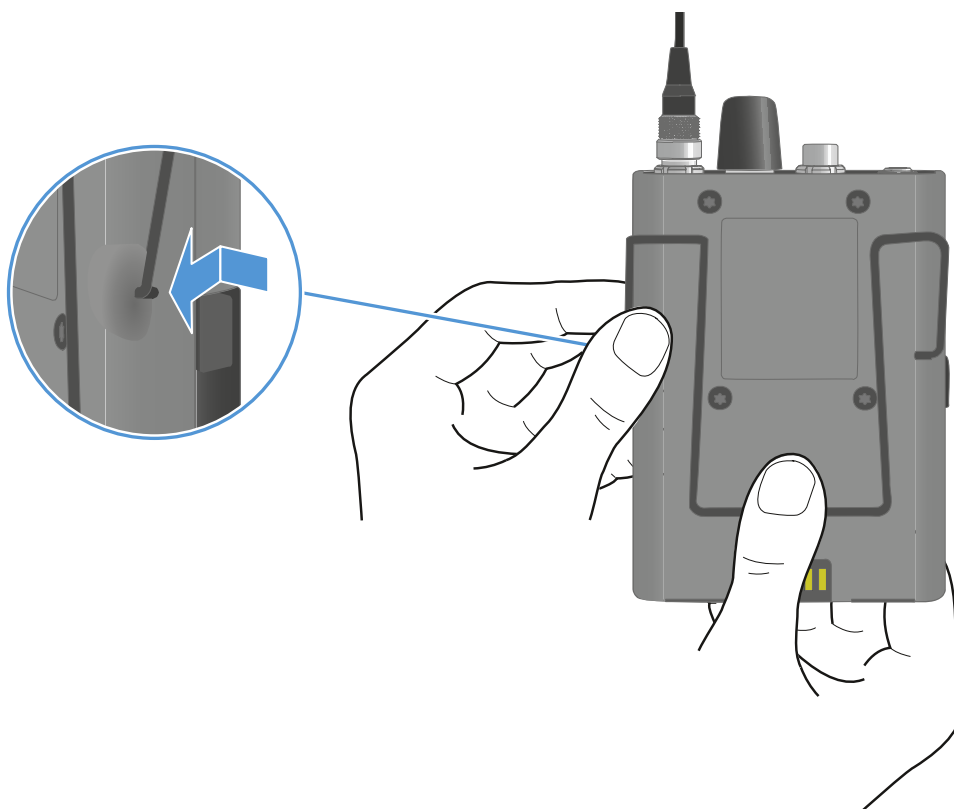

▶ Then insert the second side of the belt clip.

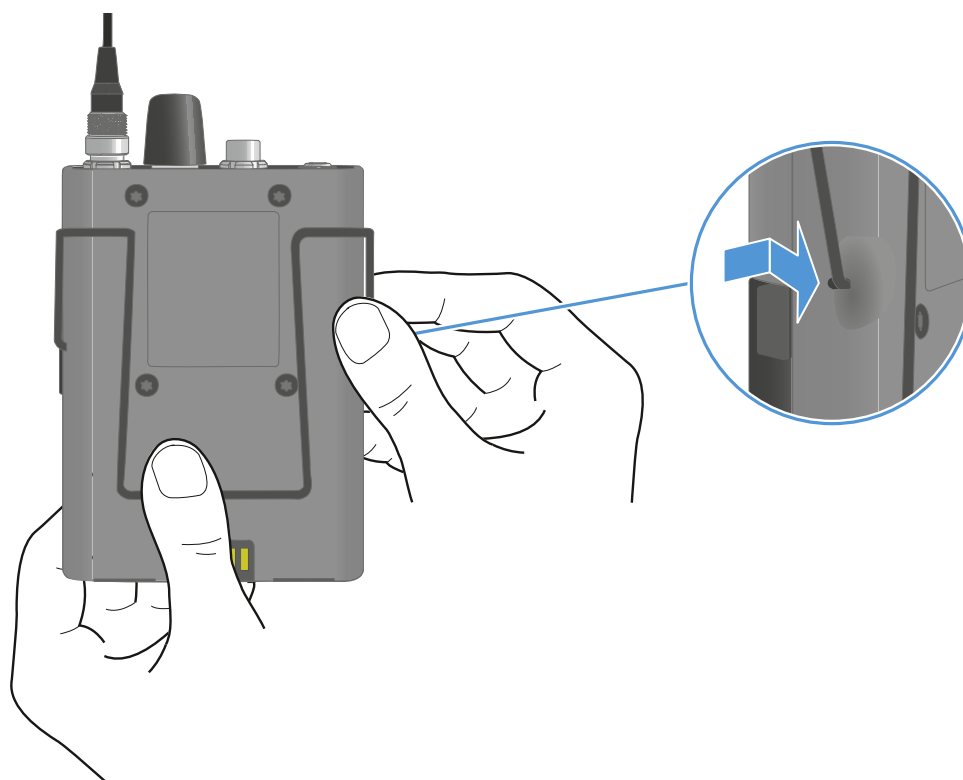



✓ The belt clip has been removed and inserted.



## Meaning of the LEDs

The **Status LED** and **LEDs** can indicate the following information.

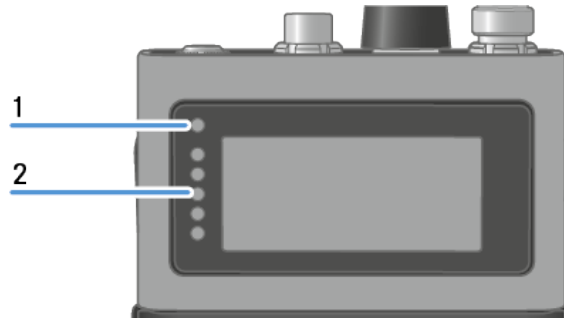





1 **Status LED**

2 **LEDs**

### Status LED

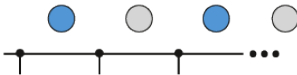
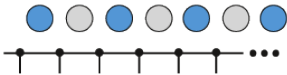
The **Status LED** provides information about the status between the SEK and Base Station, as well as status information for the SEK.

|   |   |
|---|---|
|  | The LED is off: <ul style="list-style-type: none"><li>• SEK is switched off</li></ul>   |
|  | The LED is orange: <ul style="list-style-type: none"><li>• SEK is starting</li></ul>  |
|  | The LED is flashing blue: <ul style="list-style-type: none"><li>• Searching for a new Base Station to pair</li></ul>  |
|  | The LED is flashing blue quickly: <ul style="list-style-type: none"><li>• Pairing to new Base Station is in progress</li><li>• SEK turns off after five minutes, when no Base Station was found</li></ul> |
|  | The LED is blue: <ul style="list-style-type: none"><li>• Connected to new Base Station, waiting for confirmation</li></ul>  |

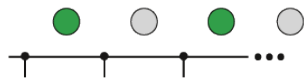

The LED is flashing green:

- SEK is searching for previously paired Base Station

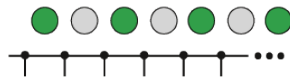

The LED is flashing green quickly:

- SEK is connecting to previous paired Base Station



The LED is green:

- SEK is on
- SEK is connected to the Base Station



The LED is pulsing green:

- SEK is in sleep mode

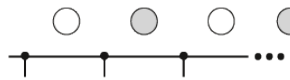

The LED is flashing white:

- Identify of SEK is in progress

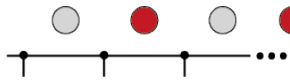

The LED is flashing red:

- Battery state is below 10 %

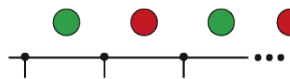

The LED is flashing green and red:

- Firmware update is in progress

## LEDs

The **LEDs** provide information about the mic line input level, if a microphone or instrument is connected to the SEK.

**i** You have to set up an audio link in LinkDesk or Spectera WebUI.

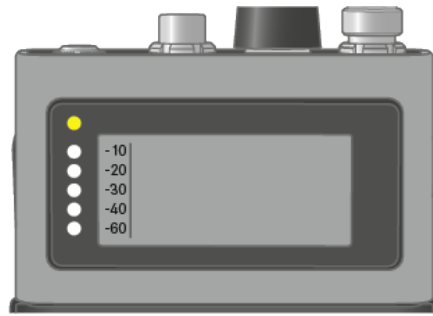
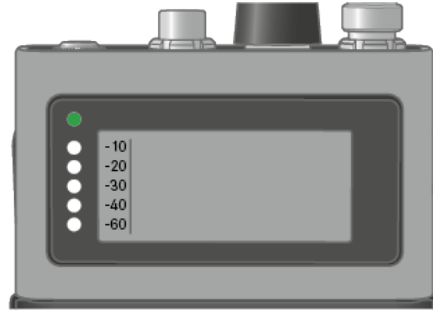

above -5 dBFS RMS

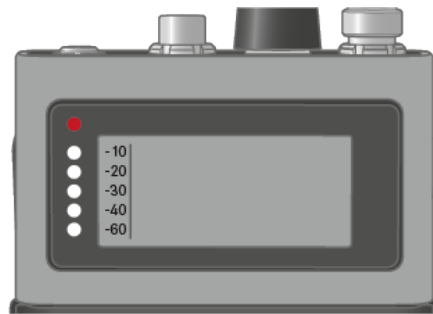

above -1 dBFS  
PEAK

---



## Switching the SEK on and off

### To switch the SEK on:

- ▶ Short-press the ON/OFF button.

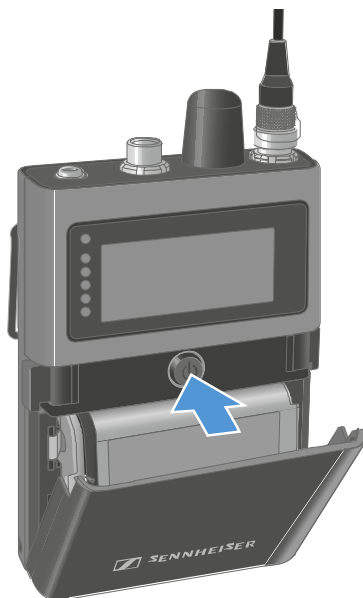

- ✓ The SEK is starting. The status LED is orange.

### To put the SEK in pairing mode:

- ▶ When the SEK is off, long press the ON/OFF button.
- ✓ The SEK is searching for a new Base Station to pair. The status LED is flashing blue.

### To switch the SEK off:

- ▶ Press the ON/OFF button.
- ✓ The status LED goes off.

**i** The display will stay on when the device is switched off or the battery has been removed.

- ✓ The SEK has been switched on/off.

When the SEK is unpaired via the software (LinkDesk or Spectera WebUI), the SEK will automatically switch into pairing mode. The status LED is flashing blue.



### **Sleep mode**

The SEK switches to sleep mode after 5 minutes if it cannot establish a connection to the Base Station. The LED then pulses green.

Once per minute, the SEK wakes up automatically and checks whether a connection to the Base Station can be established.

Operating the jog dial wakes the SEK up immediately and it attempts to establish a connection.

In doing so, the SEK searches for a connection for 10 seconds.

If a connection is established, the SEK remains active; otherwise, it switches back to sleep mode.



## Information on the display

You can view the following information on the SEKs display.

**i** The display will stay on when the device is switched off or the battery has been removed.

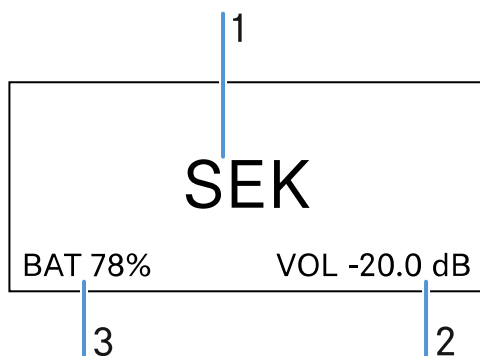

- 1 Name of mobile device
- 2 In-Ear volume level (only applicable when an audio link mode for IEM is set)
- 3 Battery status

The order of the displayed information changes depending on the setting.

- ▶ Press the rotary encoder to navigate through the menu.

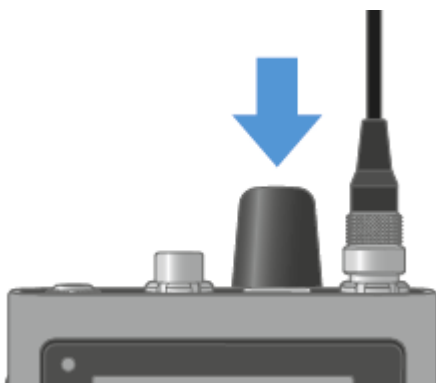

### To turn on the backlight:

**i** No microphone or headphone is connected.

- ▶ Press the rotary encoder.
  - ✓ The backlight is on for five seconds.



**To check the battery status:**

**i** No audio link is set.

- ▶ Press the rotary encoder for two times.

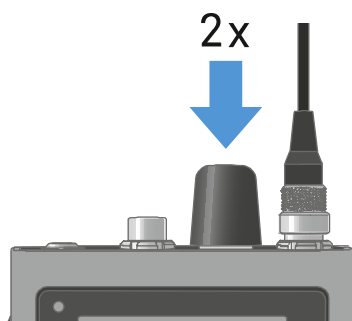

- ✔ The battery status displays for five seconds.

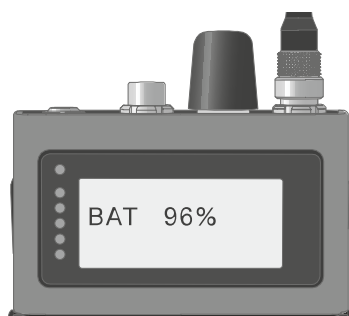

**To display the headphone volume:**

**i** Only available if in-ear audio link mode is activated.

- ▶ Press the rotary encoder.
  - ✔ The backlight is on for five seconds.
- ▶ Press the rotary encoder again within 5 seconds after the first press.
  - ✔ The headphone volume displays for five seconds.



**i** The volume can be altered between -100 dB to +27.5 dB in steps of 0.5 dB.

- ▶ Turn the rotary encoder slowly to change the volume.
  - ✓ The volume changes by 0.5 dB per click.
- ▶ Turn the rotary encoder quick to change the volume.
  - ✓ The volume changes dynamically in larger increments.

**To display the mic/line level:**

**i** Only available if mic audio link is activated.

- ▶ Press the rotary encoder.
  - ✓ The backlight is on for five seconds.
- ▶ Press the rotary encoder again within 5 seconds after the first press.
  - ✓ The mic/line level is displayed. The five LEDs show the input level.

**To display the E-label:**

**i** The SEK is paired to the Base Station and the activated license uses E-labels.

- ▶ Press the rotary encoder.
  - ✓ The backlight is on for five seconds.
- ▶ Press the rotary encoder till the end of the menu.
- ▶ Press the rotary encoder long for E-label screen.
  - ✓ The first page of the E-label displays.



- ▶ Press the rotary encoder again to display subsequent E-labels.
- ▶ Press the rotary encoder long to return to the information screen.
- ▶ Press the rotary encoder for two seconds to leave the E-label menu.



## Pairing the SEK to the Base Station

**i** Mobile devices can only be paired and operated with one Base Station at a time.

You can pair up to 128 mobile devices to a Base Station within one RF channel.

Please make sure that on the Base Station

- a RF channel is configured and
- this RF channel is activated (RF on).

### To pair the SEK to a Base Station:

- ▶ Put the Base Station into **Pairing Mode** using LinkDesk or Spectera WebUI.
  - ✓ The LED flashes blue.

**i** Pairing Mode is activated for five minutes. The audio signal is not interrupted.

- ▶ While the SEK is off, long-press the ON/OFF button until the Status LED is blue.
  - ✓ The status LED is flashing blue while searching for a new Base Station.

When the SEK found the Base Station, the status LED is flashing blue quickly and then is blue.

The SEK appears in the software.

- ▶ Confirm the pairing in the software, see LinkDesk: [Adding mobile devices](#) and Spectera WebUI: [Pairing/unpairing mobile devices](#).
  - ✓ The status LED of the SEK is flashing green quickly while connecting. When connecting is completed, the status LED is green.

### To unpair the SEK from a Base Station:

- ▶ The SEK can only be unpaired in LinkDesk or Spectera WebUI.
  - LinkDesk: [Pairing/unpairing mobile devices](#)
  - Spectera WebUI: [Pairing/unpairing mobile devices](#)
- ✓ The SEK will automatically switch to pairing mode. The status LED is flashing blue.

✓ The SEK has been paired to a Base Station.



## Updating the SEK

You can update the firmware of the SEK via LinkDesk or Spectera WebUI.

All Spectera devices must use the same firmware version. The Base Station determines the firmware version.

### NOTICE



#### Data loss during firmware update

The audio transmission is interrupted during the firmware update of the Base Station, the antenna or the mobile device.

After the firmware update, the device is restarted automatically.

- ▶ Do not update the firmware during an active live audio transmission.

#### To update the firmware:

- ▶ If you want to update the SEK via LinkDesk: [Updating the firmware \(mobile devices\)](#).
  - ✓ The Status LED is flashing green and red during the update.
- ▶ If you want to update the SEK via Spectera WebUI: [Updating the firmware \(mobile devices\)](#).
  - ✓ The Status LED is flashing green and red during the update.

✓ The firmware has been updated.



## DAD

### Product overview

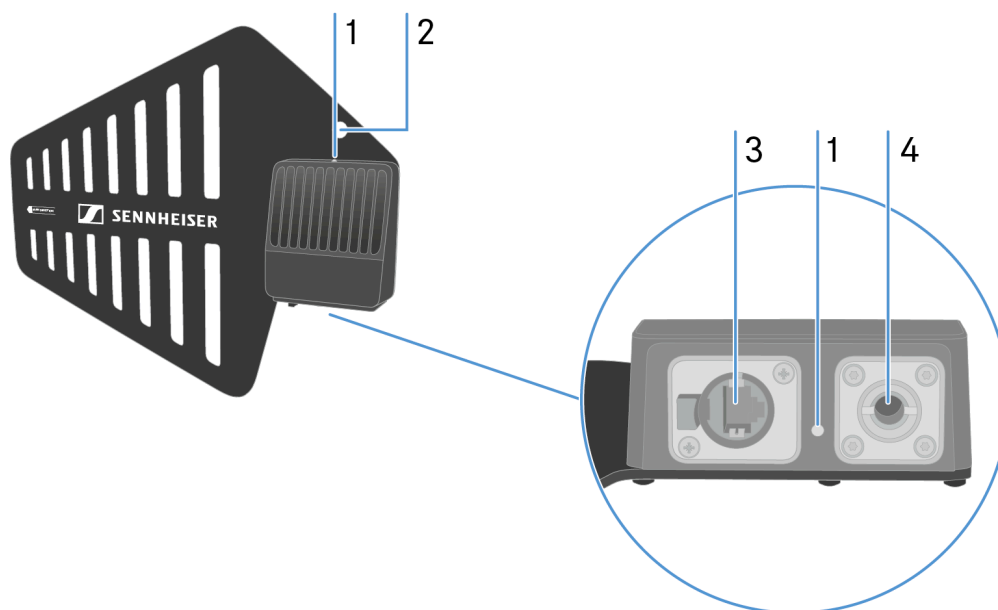

1 LED to indicate the status

see [Meaning of the LED](#)

2 Hole for rigging safety cable

3 Ruggedized RJ45

see [Connecting/disconnecting the antenna](#)

4 Microphone stand

see [Information on antenna setup](#)



## Information on antenna setup

**i** Handle with care: The antenna contains electrical components.

### Setup with other antennas

- Keep a distance more than 10 m (393.7") between the antenna and another antenna.
- Keep a distance more than 0.5 m (19.69") between the antenna and a wall.

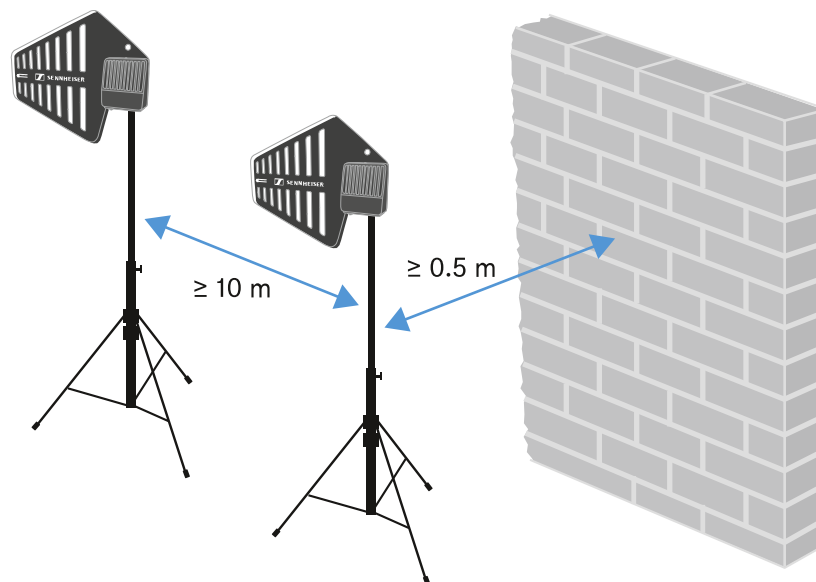

### Setup with a mobile device

- Keep a distance more than 5 m (169.85") between the antenna and the mobile device.

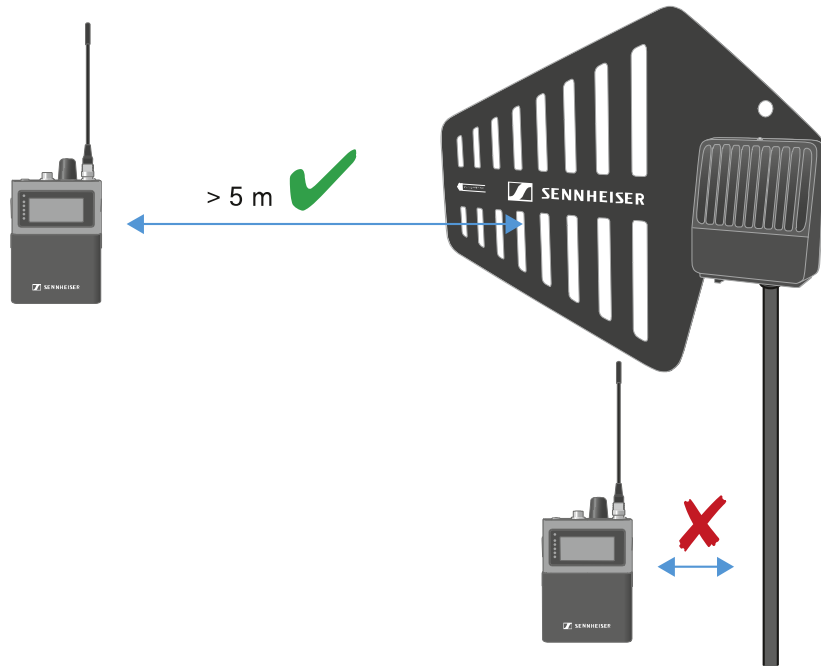



## Meaning of the LED

The LED on top and below indicates the same information.



The LED is off:

- The antenna is not connected to the Base Station.

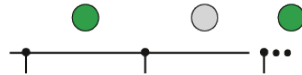

The LED is flashing green:

- The antenna is connecting to the Base Station.



The LED is green:

- The antenna is connected to the Base Station and one or both RF channels are active.



The LED is yellow:

- The antenna is connected to the Base Station and one or both RF channels are muted.

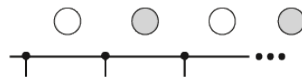

The LED is flashing white:

- The connected antenna is identified.

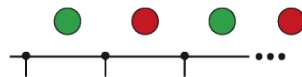

The LED is flashing green and red:

- Firmware update is in progress.



## Placing on a stand

The thread is suitable for mounting on a standard microphone stand with 3/8" or 5/8" thread.

**i** Handle with care: The antenna contains electrical components.

### CAUTION



#### **Personal injury and damage to property if the antennae should tip or fall over**

If you do not secure the antennae against tipping or falling over, they may cause personal injury and damage to property.

- ▶ Secure antennae so that they cannot tip and fall over. Use safety wires for this purpose. The safety wires, rope terminations and coupling links must comply in their dimensioning and condition with the regulations and standards of the country in which they are used!



**To place the DAD on a stand:**

- ▶ Screw the DAD to the stand.
- ▶ Make sure to use the correct hole!

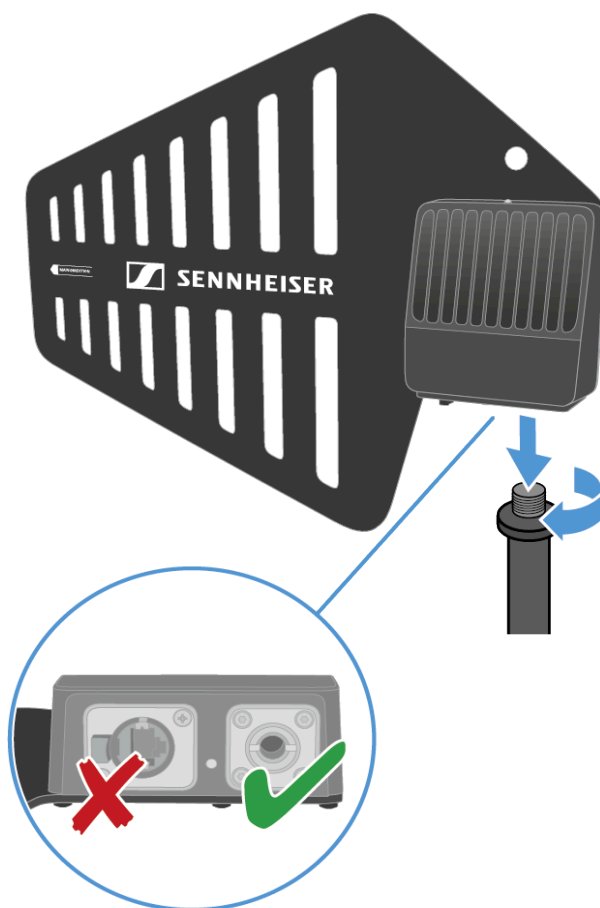

✓ The DAD has been placed on a stand.



## Connecting/disconnecting the antenna

The cable supplies power and exchanges data.

**i** Handle with care: The antenna contains electrical components.

The cable must

- be a CAT5e or higher,
- have ruggedized plugs and
- not extend 100 m (3937").

**i** We recommend using an antenna cable cat 5e (see [Accessories for the DAD](#)).

### To connect the antenna to the Base Station:

- ▶ Observe the information: [Information on antenna setup](#).

**i** The antenna must be connected directly to the Base Station, with no switch in between.

- ▶ Plug on side of the cable into the antenna.
- ▶ Make sure to use the correct hole!

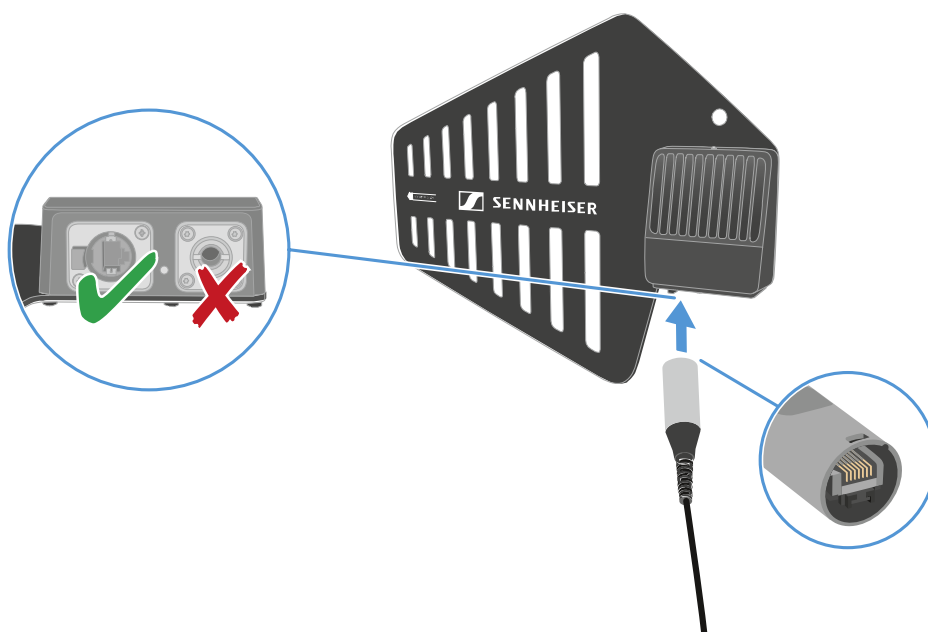



- ▶ Plug the other side of the cable into one antenna port (A, B, C or D) at the rear site of the Base Station.

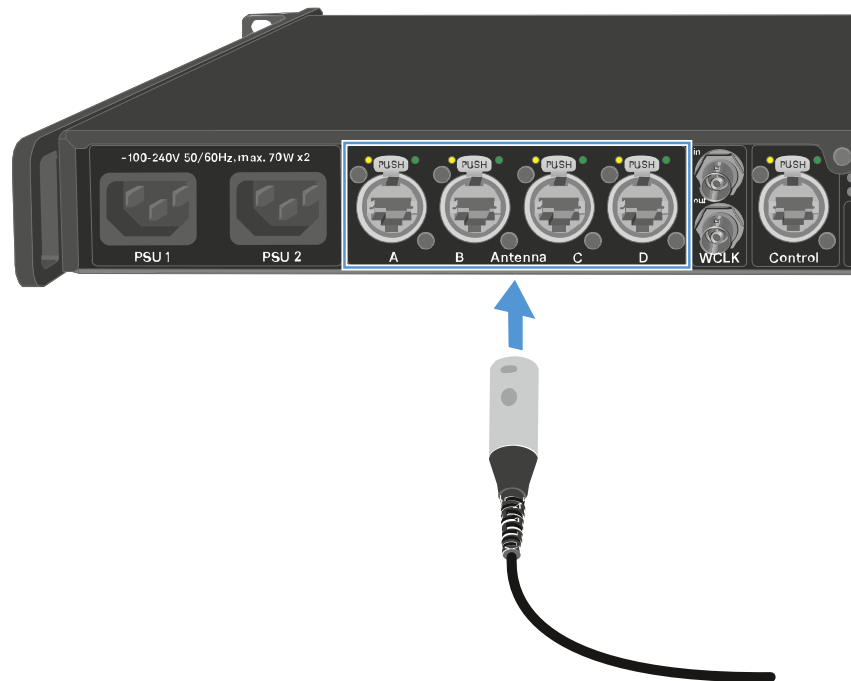

- ✓ The LED flashes green to connect to the Base Station.

The LED is green, when the antenna is connected to the Base Station and one or both RF channels are active.

Or the LED is yellow, when the antenna is connected to the Base Station and the radio signal is muted.

Or the LED is flashing green and red, when the firmware is updating automatically.

**i** If the Base Station is in standby, the DAD is off.

- ▶ You can connect up to four antennas to one Base Station.

The Base Station has two independent RF channels. Both variants of the antenna (UHF and 1G4) can be connected to the Base Station at the same time.

**To disconnect the antenna from the Base Station:**

- ▶ Hold the push button down.
- ▶ Unplug the cable from the Base Station.



**To disconnect the cable from the antenna:**

- ▶ Hold the snap-in nose down.

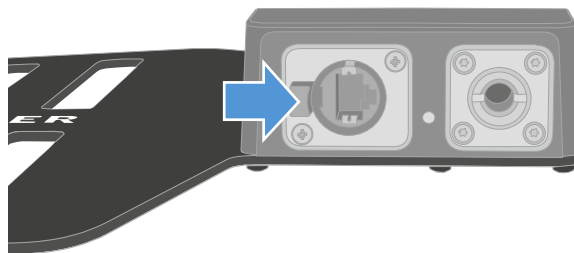

- ▶ Unplug the cable from the antenna.

✓ The antenna has been connected/disconnected.



## Antenna cable extension

Longer cable distances are possible with the use of fiber optic cables and media converters.

Sennheiser tested the recommend converters for a complete distance of 4 km (157480.31").

We only recommend the following converters for fully tested functionality:

**i** It is mandatory to use the media converters in pairs.

- Lantronix M/GE-PSW-PSE-01 (with PoE for DAD) **or**
- Lantronix M/GE-T-SFP-01 (needs a Class 2 PoE injector capable of supplying powering to the DAD (power consumption < 6.5 W)) **or**
- Barnfind Technologies BarnColor 4xEth (with PoE for DAD) **or**
- ProLabs 10/100/1000Base-TX(RJ-45) to Open SFP Port POE+ Media Converter (C-GMC-SFP-POE+, with PoE for DAD)

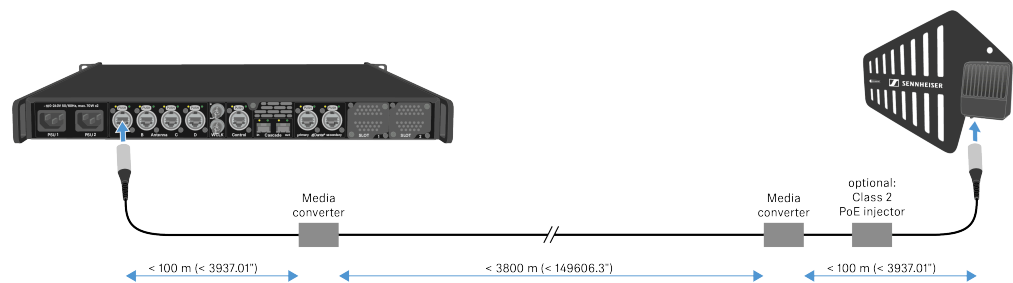

**i** The media converter must not have a switch function.



## Updating the DAD

The firmware of the antenna will update automatically, when connected to the Base Station.

### NOTICE



#### Data loss during firmware update

The audio transmission is interrupted during the firmware update of the Base Station, the antenna or the mobile device.

After the firmware update, the device is restarted automatically.

- ▶ Do not update the firmware during an active live audio transmission.

#### To update the firmware:

- ▶ Connect the antenna to a Base Station. See [Connecting/disconnecting the antenna](#). To update the Base Station, see [Updating the Base Station](#).
- ✓ The LED is flashing green and red during the update.

✓ The firmware has been updated.



## CHG 70N-C charger

The CHG 70N-C is a network enabled charger featuring two individual charging bays.

Compatible products:

- EW-DX SKM/EW-DX SKM-S handheld transmitter
- EW-DX SK/EW-DX SK 3-PIN bodypack transmitter
- SPECTERA SEK bidirectional transmitter
- BA 70 rechargeable battery

## Product overview

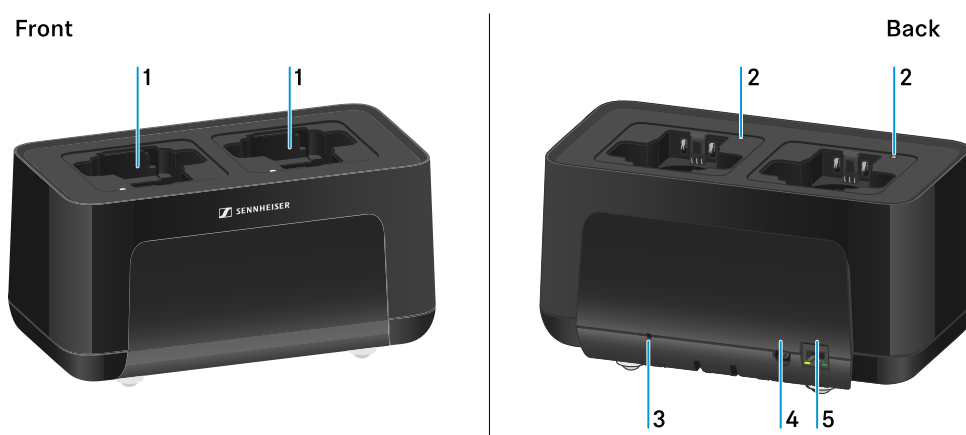

### 1 Charging slots

- See [Charging the rechargeable battery](#)

### 2 Status LED of the charging slots

- See [Charging the rechargeable battery](#)

### 3 Reset button

- Press and hold for 10 seconds to reset the device's network settings, see [Connecting a charger in a network](#)
- Press and hold for 4 seconds to enable power saving mode, see [Power saving mode](#)

### 4 DC in connection socket for the NT 12-35 CS power supply unit

- See [Connecting/disconnecting the charger to/from the power supply system](#)



**5 PoE/Ethernet** RJ45 socket for controlling the device over the network and for Power over Ethernet power supply

- See [Connecting a charger in a network](#)
- See [Connecting/disconnecting the charger to/from the power supply system](#)

**i** You can cascade up to 5 devices with only one power supply and one network connection. See [Cascading chargers](#).



## Connecting/disconnecting the charger to/from the power supply system

You can operate the charger either with the Sennheiser NT 12-35 CS power supply unit or with Power over Ethernet (PoE IEEE 802.3af Class 0). Please refer to the following information.

### Power from the NT 12-35 CS power supply unit

- ▶ Use only the **NT 12-35 CS** power supply unit from Sennheiser. It is designed for your charger and ensures safe operation.

**i** The power supply unit is available either separately (Sennheiser article number 508995) or together with the charger as a kit (see [CHG 70N-C network-enabled charger](#)).

### Power from the NT 12-35 CS power supply unit

**i** Use only the **NT 12-35 CS** power supply unit from Sennheiser. It is designed for your charger and ensures safe operation. The power supply unit is available either separately (Sennheiser article number 508995) or together with the charger as a kit (see [CHG 70N-C network-enabled charger](#)).

- ▶ Connect the hollow jack plug of the power supply unit to the **DC in** socket on the charger.
- ▶ Pass the cable through the strain relief.
- ▶ Plug the power supply unit into the wall outlet using the correct power cable for your country.

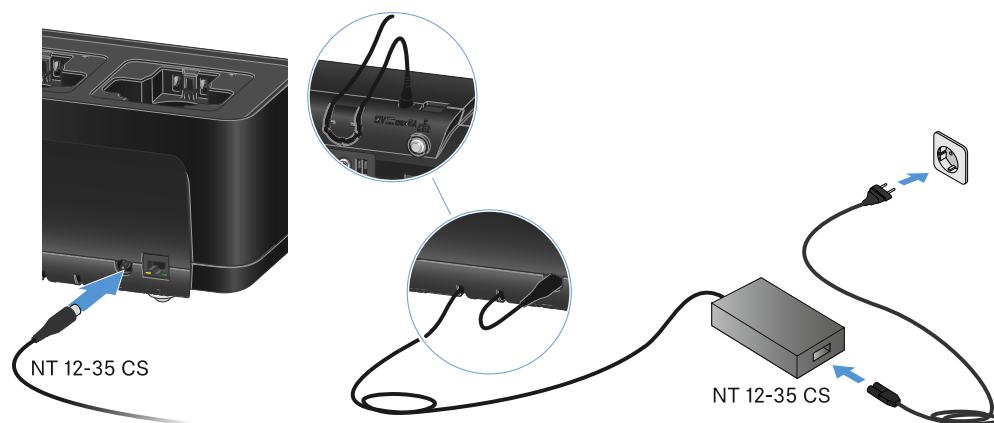



### Disconnecting the charger completely from the power supply system

- ▶ Unplug the mains cable from the wall socket.
- ▶ Unplug the hollow jack plug of the power supply unit from the **DC in** socket on the charger.

### Power over Ethernet (PoE)

**i** The charger can be powered via **Power over Ethernet** (PoE IEEE 802.3af Class 0).

- ▶ Connect the charger to a **PoE-enabled** network switch.

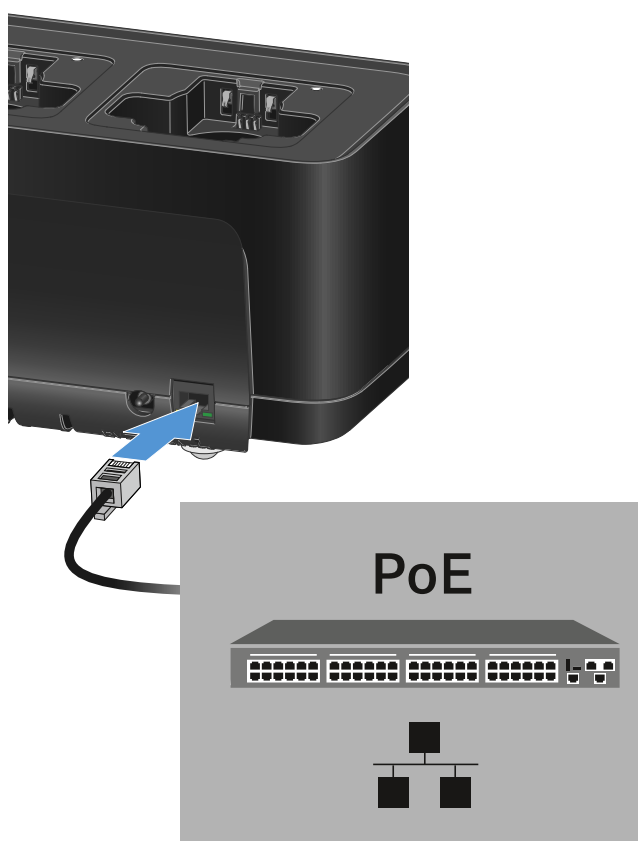



## Connecting a charger in a network

You can monitor and control one or more chargers via a network connection using the **Sennheiser Control Cockpit (SCC)** software.

- i** The network does not have to be a homogeneous network including only chargers. You can integrate the charger into your existing network infrastructure with any other types of devices.

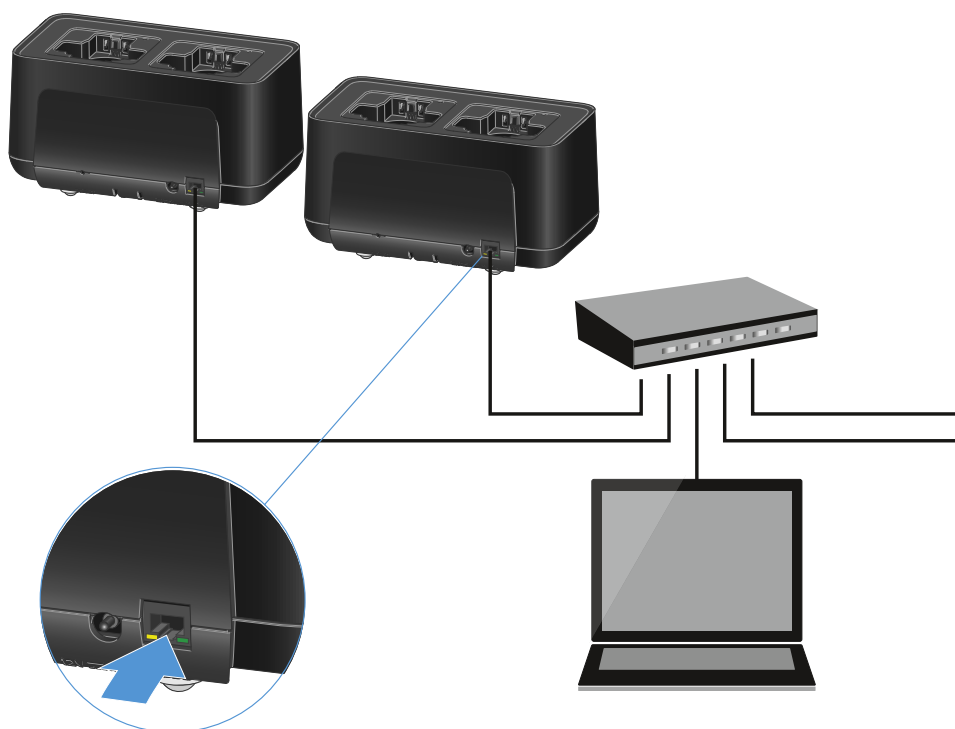

You can integrate the devices into the network individually or cascade up to 5 chargers (see [Cascading chargers](#)).

### To reset the network settings to their factory defaults:

- ▶ Hold the **Reset** button for 4 seconds.

- i** For more information about controlling devices via the Sennheiser Wireless Systems Manager or Sennheiser Control Cockpit software, refer to the instruction manual for the software. You can download the software here: [sennheiser.com/control-cockpit](https://sennheiser.com/control-cockpit)



## Cascading chargers

You can cascade up to five CHG 70N-C chargers and operate them with a single power supply and a single network connection. This minimizes the cabling required for larger systems.

- i** The power must be supplied via the NT 12-35 CS power supply unit. Power over Ethernet (PoE) is not possible when cascading.

### To cascade the chargers:

- ▶ Make sure that no chargers are connected to the power before you start.
- ▶ Plug the chargers into each other as shown in the figure.

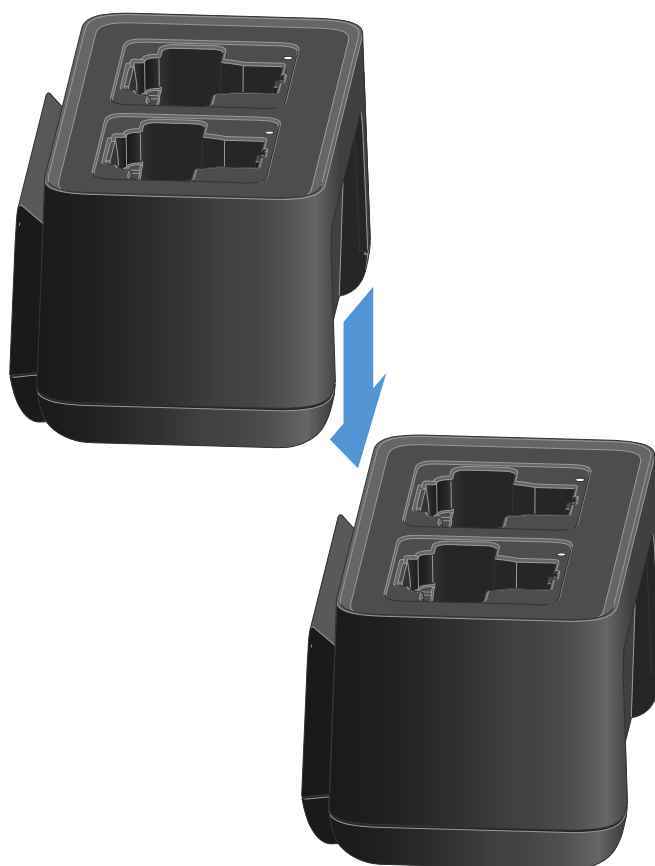

- ▶ Detach the connecting rail on the bottom of the charger.
- ▶ Fasten the connecting rail beneath two chargers as shown in the figure.
- ✔ The power and the network connection are passed on to all devices via the connecting rails.

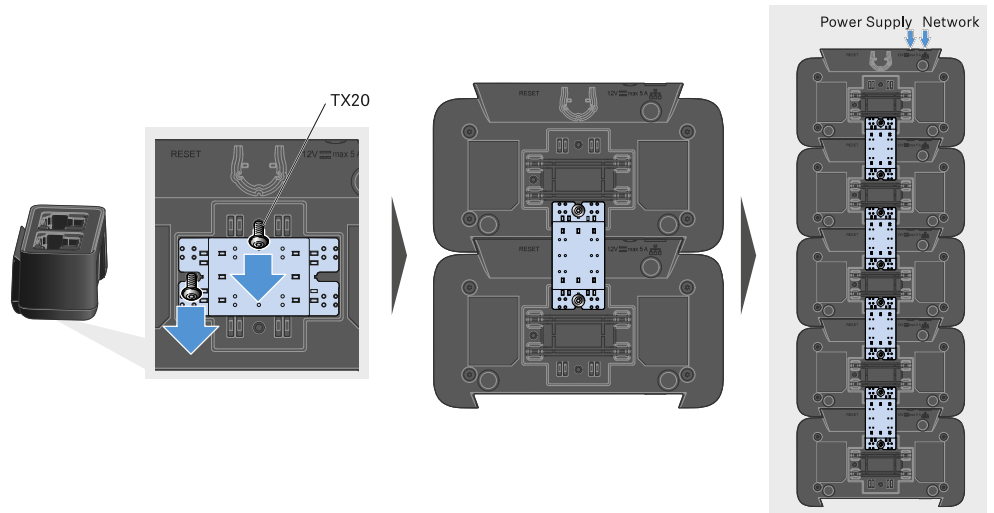

- ▶ Connect the first charger in the cascade to the network (see [Connecting a charger in a network](#)).
- ▶ Finally, connect the NT 12-35 CS power supply unit to the first charger in the cascade (see [Connecting/disconnecting the charger to/from the power supply system](#)).

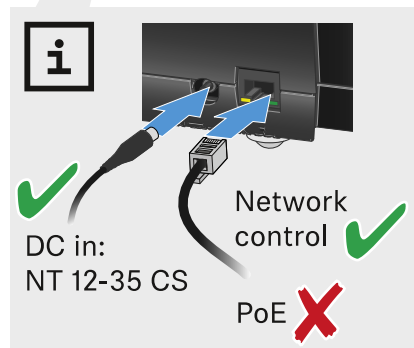



## Charging the rechargeable battery

You can use the CHG 70N-C charger to charge individual BA 70 rechargeable batteries, or to charge EW-DX SKM, EW-DX SKM-S, EW-DX SK, EW-DX SK 3-PIN or Spectera SEK with the BA 70 rechargeable battery already inserted.

### To charge the battery:



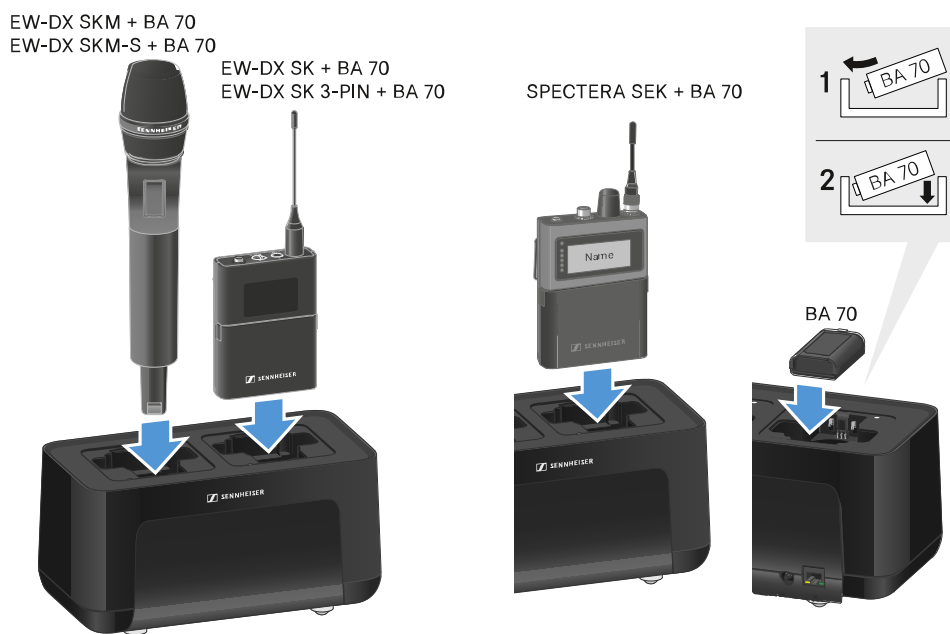



- ▶ Insert the individual rechargeable battery or the transmitter with battery already inserted into the charging slot as shown in the figure.

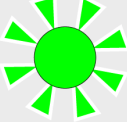

- ✔ The rechargeable battery will begin charging.

The LED on the charging slot shows the battery's charge level.



| LEDs  |  |
|---|---|
|    | 100 %   |
|    | > 60 %  |
|    | > 20 %  |
|    | > 0 %   |
|  | Error   |



## Power saving mode

In power saving mode, the transmitters are charged only once. The charger also does not provide any trickle charge.

### To activate power saving mode:

**i** In power saving mode, the CHG 70N-C cannot be controlled over the network.

- ▶ Remove all transmitters and/or rechargeable batteries from the charging slots.
- ▶ Hold the **Reset** button for 4 seconds.
  - ✓ The charging slot LEDs light up purple.
- ▶ Insert the rechargeable battery/transmitter for charging.
  - ✓ The rechargeable battery will begin charging. The charging slot LED turns green once it reaches full charge.

### To deactivate power saving mode:

- ▶ Disconnect the charger from the power supply system.
- ▶ Then reconnect it to the power supply system.
  - ✓ The charger will start up in the configuration that was set before you activated power saving mode.



## Updating the firmware of the charger

You can update the charger firmware using the **Sennheiser Control Cockpit** software.



**i Note on firmware version 4.0.0**

Devices with outdated firmware can no longer be reached in a cascade if the first charger has the new firmware.



- ▶ Disconnect the chargers from the cascade.

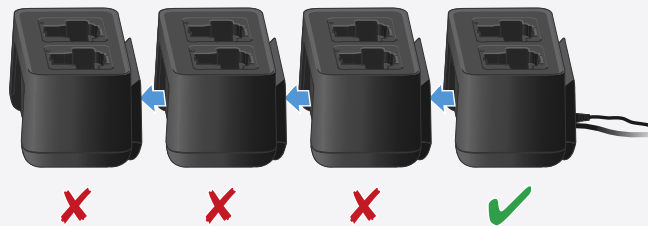

- ▶ Update the firmware of each charger individually.

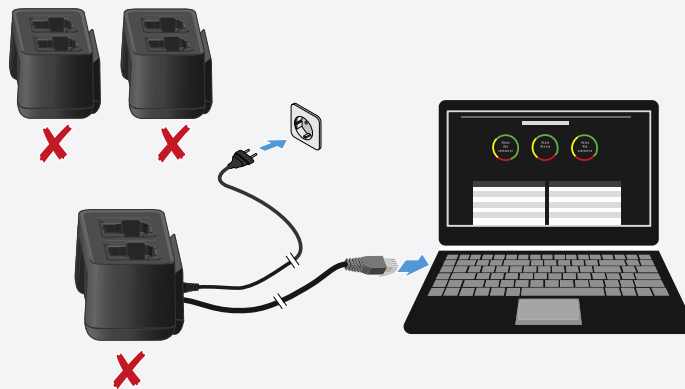

- ▶ Connect the chargers.





**Updating with the Sennheiser Control Cockpit:**

- ▶ Connect the charger to a network (see [Connecting a charger in a network](#)) and establish the connection with the software.

**i** For more information about controlling devices with the **Sennheiser Control Cockpit** software, refer to the software help. You can download the software here:  
[sennheiser.com/control-cockpit](https://sennheiser.com/control-cockpit)



## L 70 USB charger

### Connecting/disconnecting the charger to/from the power supply system

#### To connect the charger to the power supply system:

- ▶ Use only the **NT 5-20 UCW** power supply unit from Sennheiser.
- ▶ Connect the USB-C plug on the charging cable to the USB-C port on the side of the charger.
- ▶ Plug the power supply unit with the correct country adapter into a suitable power outlet.

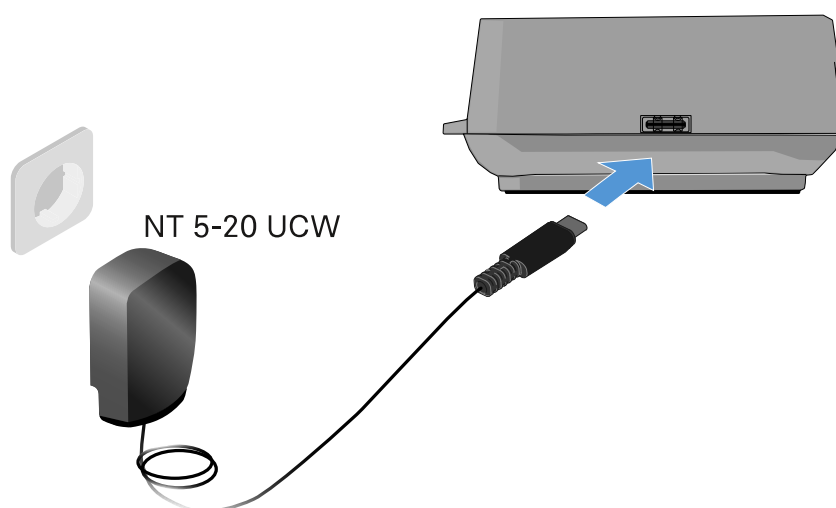

#### To disconnect the charger from the power supply system:

- ▶ Unplug the power supply unit from the wall socket.
- ▶ Remove the USB-C plug on the charging cable from the USB-C port on the side of the charger.



## Charging the rechargeable battery

To charge the BA 70 rechargeable battery in the L 70 USB charger:



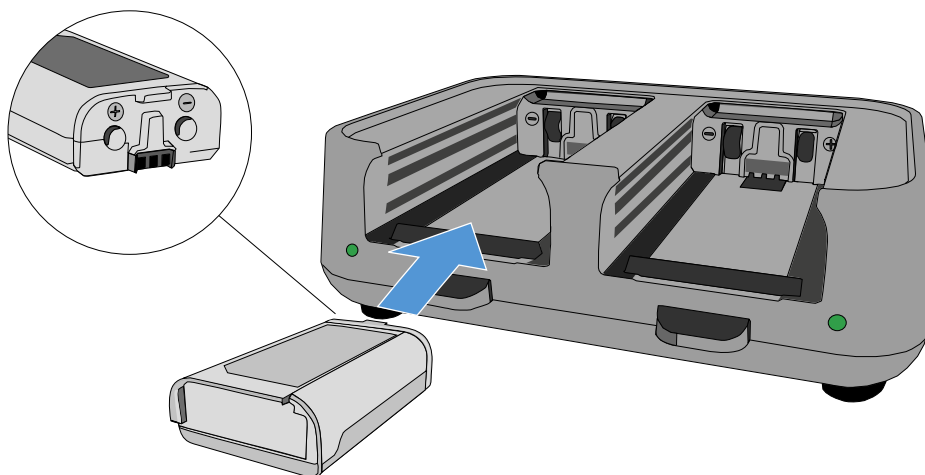

- ▶ Slide the rechargeable battery completely into the charging slot as shown in the figure.



- ✔ The rechargeable battery will begin charging.

The LED on the charging slot shows the battery's charge level:

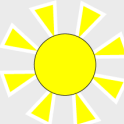

| LEDs  |  |
|---|---|
|    | 100 %   |
|    | > 60 %  |
|    | > 20 %  |
|    | > 0 %   |
|  | Error   |



## Modular L 6000 charger

These sections contain information about installing, starting up and operating the modular L 6000 charger and the corresponding charging modules.

### Product overview

#### Front

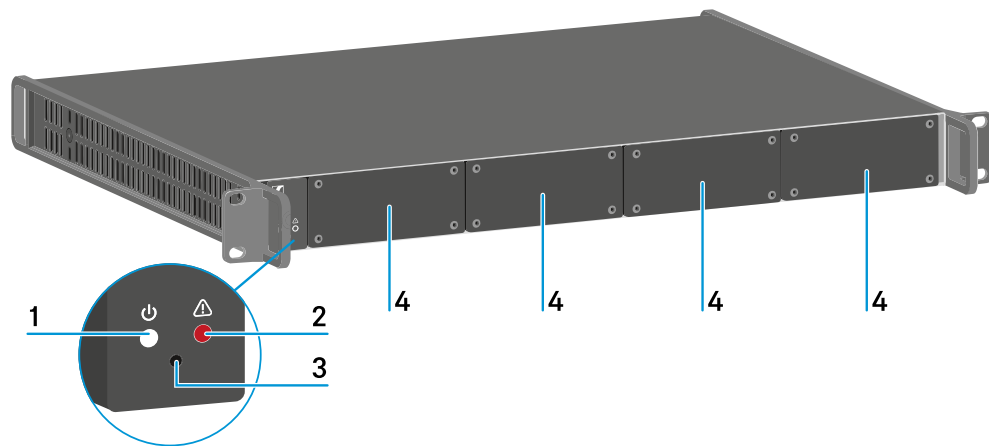

1 Power status LED

See [Meaning of the LEDs](#)

2 Warning status LED

See [Meaning of the LEDs](#)

3 Reset

See [Resetting settings \(factory reset\)](#)

4 Dummy caps

See [Installing a charging module in the L 6000 charger](#)

#### Back

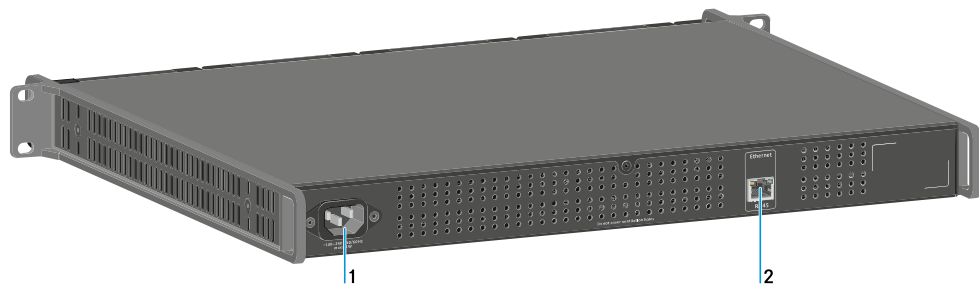

1 Power socket

See [Connecting/disconnecting the L 6000 to/from the power supply system](#)



**2 Ethernet** socket

See [Connecting the L 6000 to a network](#)



## Connecting/disconnecting the L 6000 to/from the power supply system

### To connect the L 6000 to the power supply system:

- ▶ Connect the mains cable IEC connector to the power socket on the rear side of the L 6000.
- ▶ Connect the mains cable plug into a suitable wall socket.

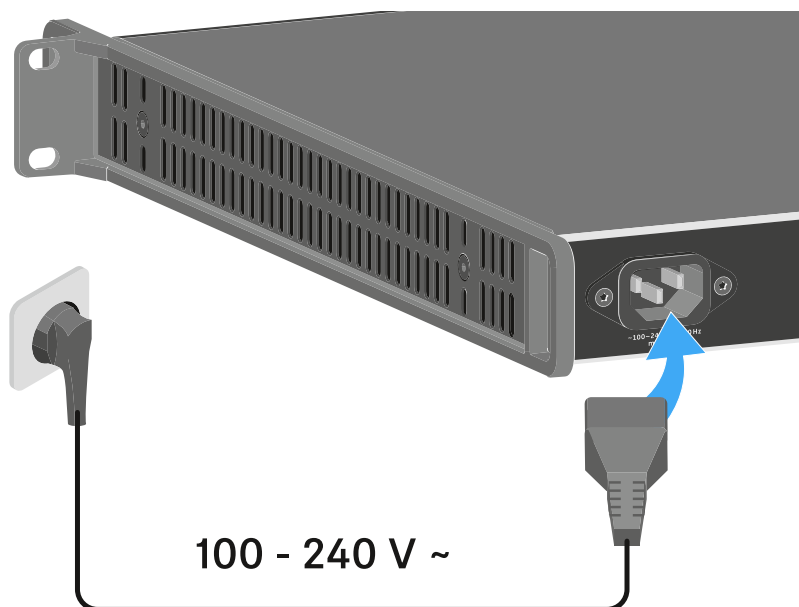

### To completely disconnect the L 6000 from the power supply system:

- ▶ Unplug the mains cable plug from the wall socket.
- ▶ Unplug the mains cable IEC connector from the power socket on the rear side of the L 6000.



## Connecting the L 6000 to a network

You can monitor and control one or more L 6000s via a network connection using the **Sennheiser Wireless Systems Manager (WSM)** software.

The network does not have to be a homogeneous network including only chargers. You can integrate the L 6000 into your existing network infrastructure with any other types of devices.

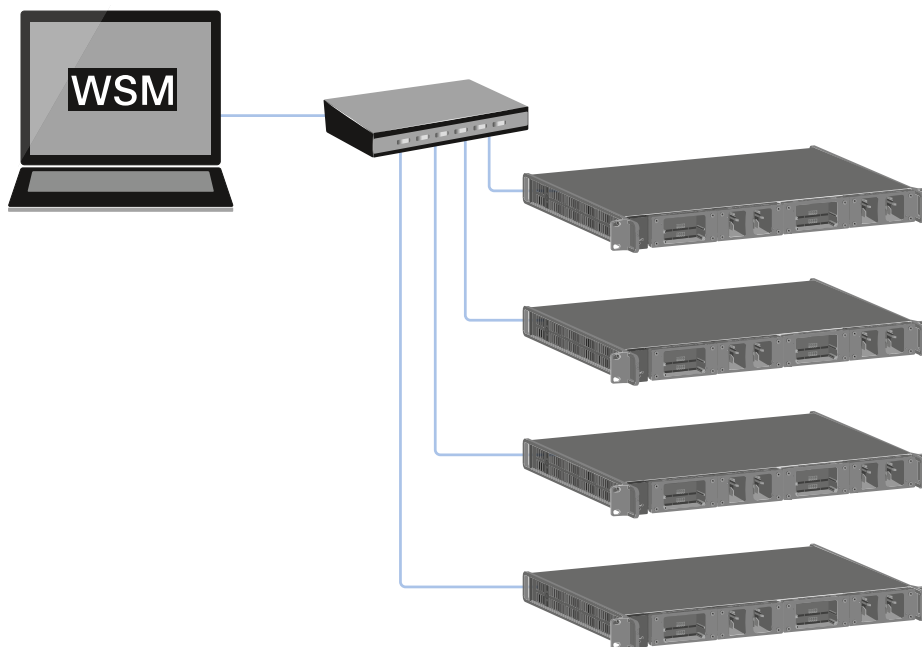



**To connect the L 6000 to a network:**

- ▶ Connect a network cable with an RJ-45 connector (Cat5 at minimum) to the **Ethernet** socket on the rear side of the L 6000.

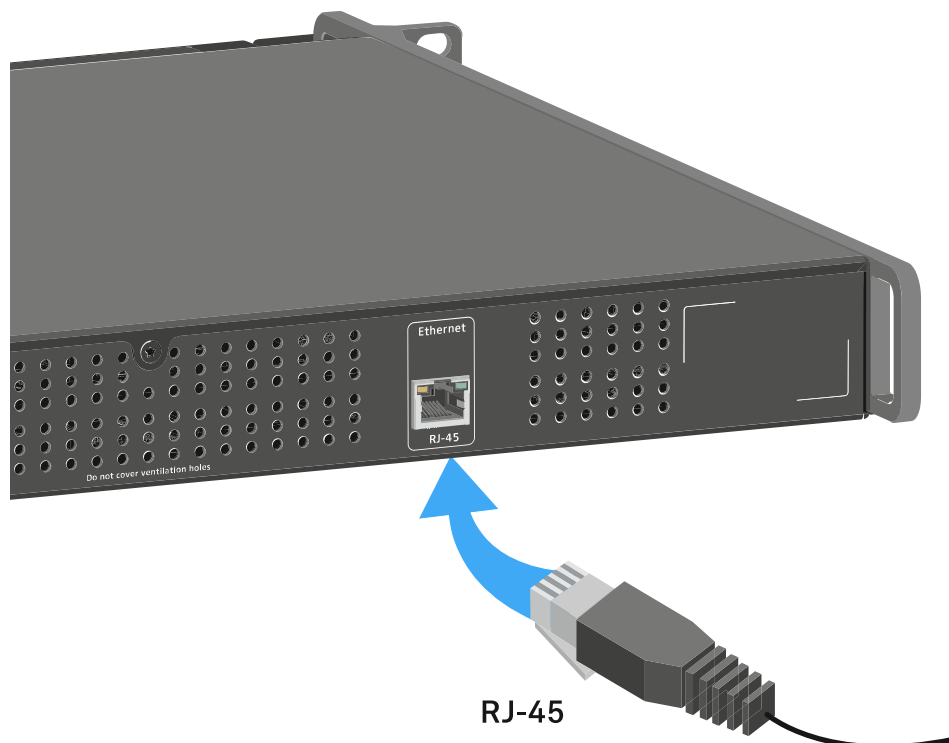

**i** For more information about controlling devices via the **Sennheiser Wireless Systems Manager** (WSM) software, refer to the instruction manual for the software. You can download the software here: [sennheiser.com/wsm](https://sennheiser.com/wsm)



## Installing a charging module in the L 6000 charger

The following charging modules are available for the L 6000 charger.

- **LM 6060** -> for charging the **BA 60** rechargeable battery

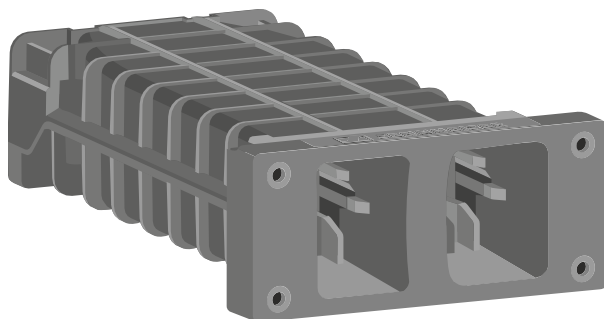

- **LM 6061** -> for charging the **BA 61** rechargeable battery

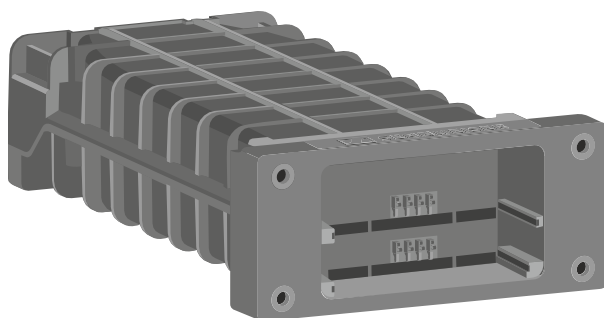

- **LM 6062** -> for charging the **BA 62** rechargeable battery

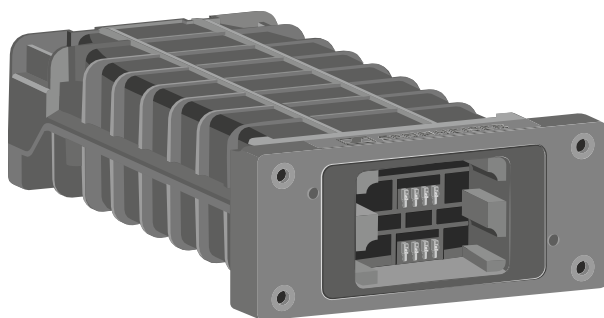

- **LM 6070** -> for charging the **BA 70** rechargeable battery

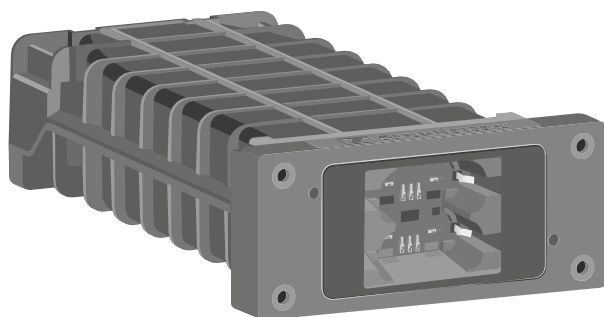



You can combine the LM 6060, LM 6061, LM 6062 and LM 6070 in any way in the L 6000 charger.

**To install a charging module in the L 6000 charger:**

- ▶ Completely disconnect the L 6000 charger from the power supply system. See [Connecting/disconnecting the L 6000 to/from the power supply system](#).
- ▶ Unscrew one of the dummy caps on the L 6000. To do so, you require a Torx 10 screwdriver.

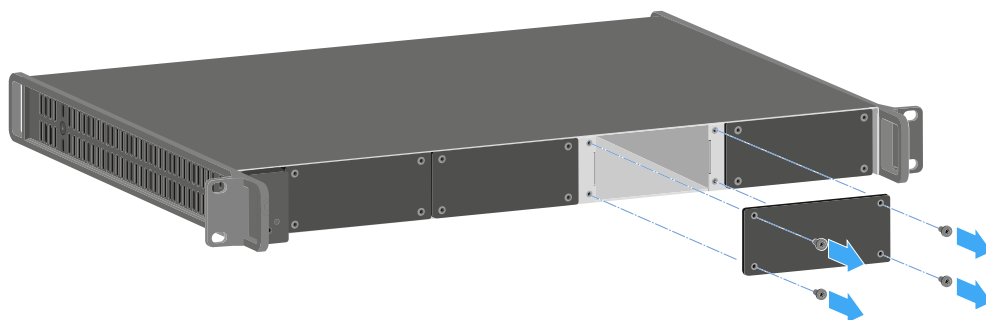

- ▶ Fully slide the charging module into the open charging slot as shown in the figure.
  - ✓ The charging module can be inserted into the L 6000 housing only in one direction. The Sennheiser lettering on the charging module must face upward.

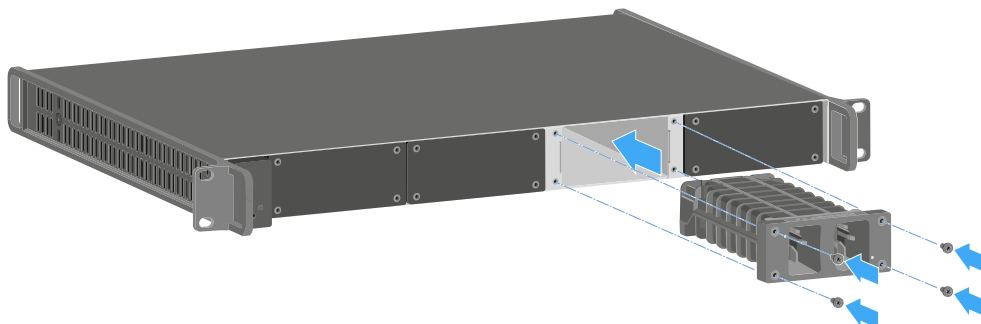

- ▶ Tightly screw on the charging module.

Always use the latest firmware for the L 6000 charger (version 2.0 or later) to ensure you have access to the full range of functions. You can download the latest firmware from the following address:

[sennheiser.com/l-6000](https://sennheiser.com/l-6000)

**i** For more detailed information about charging the BA 60, BA 61 and BA 62 and BA 70 rechargeable batteries, see [Charging the rechargeable batteries in the L 6000 charger](#).



## Installing the L 6000 in a rack

You can install the L 6000 charger in any conventional 19" rack.

The rack mounting angles are already attached to the device.

Always observe the following information during rack mounting.

### NOTICE



#### Material damages caused by devices overheating

When there is insufficient ventilation, the devices mounted in the rack may overheat.

- ▶ Ensure that there is sufficient ventilation in the rack, particularly if several devices are installed.
- ▶ If necessary, install a fan in the rack.

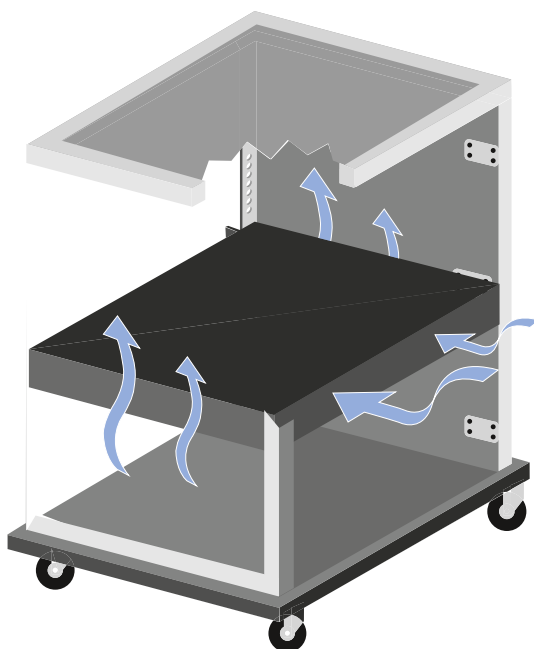



- ▶ Support the EM 6000 after installation in the rack. Due to the weight and depth of the device, there is a risk that it may break off in the rack and become damaged as a result.

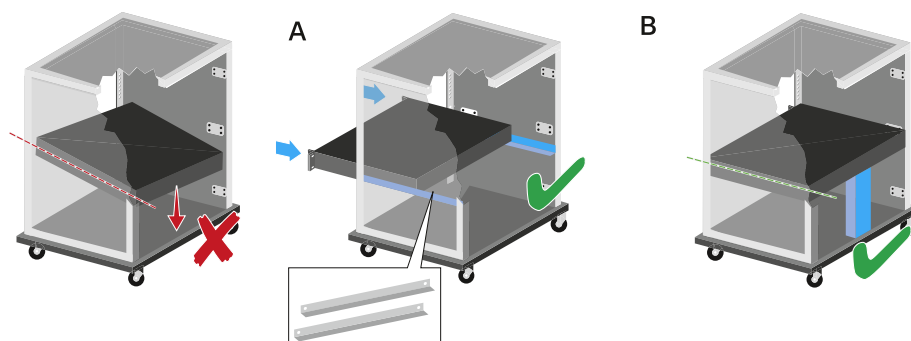

**Version A:**

- ▶ Use special rack mounting rails.
- ▶ The design of the rack used must be suitable for the installation of these mounting rails.

**Version B:**

- ▶ Use a suitable object to support the device on the rear side.
- ▶ Ensure that this object cannot become loose.



## Switching the L 6000 on and off

The L 6000 does not have a separate on/off switch.

Once the power supply is established, the device is switched on.

- ▶ See [Connecting/disconnecting the L 6000 to/from the power supply system](#).



## Charging the rechargeable batteries in the L 6000 charger

To charge the BA 60, BA 61, BA 62 and BA 70 rechargeable batteries with the L 6000 charger, you need the LM 6060, LM 6061, LM 6062 or LM 6070 charging modules.

Before charging, you have to install the charging modules in the L 6000 charger. For installation information, see [Installing a charging module in the L 6000 charger](#).

**i** **Note on the charger firmware**

Always use the latest firmware for the L 6000 charger (version 2.0 or later) to ensure you have access to the full range of functions. You can download the latest firmware from the following address:

[sennheiser.com/l-6000](https://sennheiser.com/l-6000)

**i** **Note on the BA 62 rechargeable battery for the SK 6212 bodypack transmitter**

It is possible that new rechargeable batteries cannot be fully charged to 100 % in the first few charging cycles.

The remaining operating time may still be unclear after the first few charging cycles. This will improve over time after more charging cycles because the rechargeable battery calibrates itself.

### NOTICE



**Damage to the charging contacts in the charging slot**

If you touch the contacts in the charging slot, they may become dirty or bent.

- ▶ When replacing and removing the rechargeable batteries, ensure that you do not touch the charging contacts in the charging slots.



**To charge the rechargeable batteries:**

- ▶ Insert the rechargeable battery into the charging module as shown in the figure until it audibly clicks into place.
- ✓ The rechargeable batteries can be inserted into the charging modules only in one direction. You can see the charge level of the rechargeable batteries from the LEDs on the charging modules (see [Meaning of the LEDs](#)).

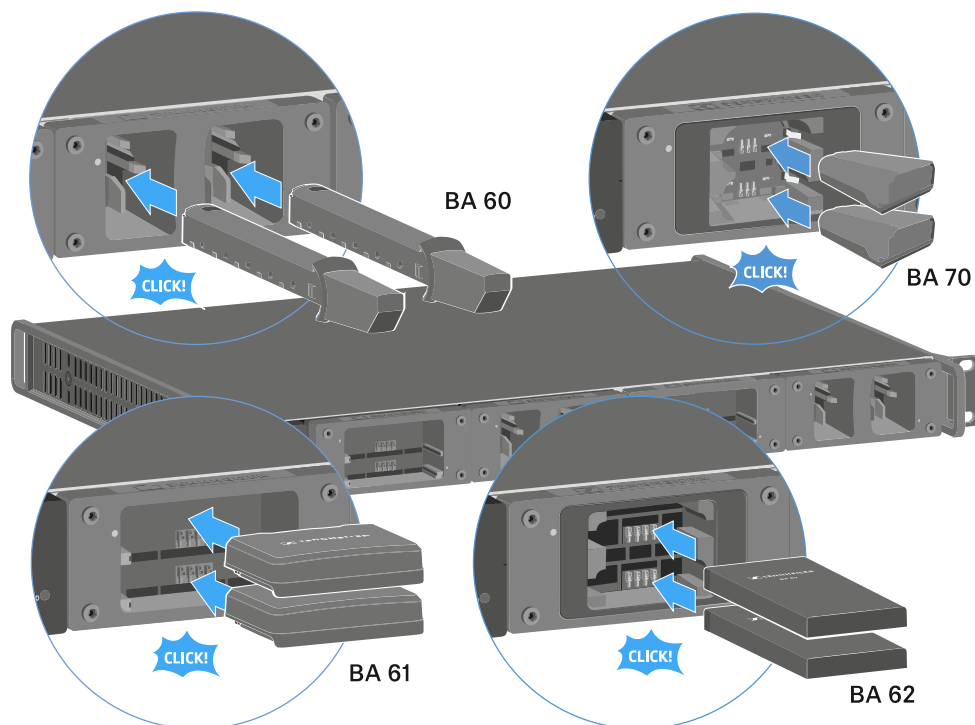

**i** At ambient temperatures of 45° C (113° F) and above, the rechargeable batteries can no longer be fully charged. They can only be charged to a maximum of 70 %.









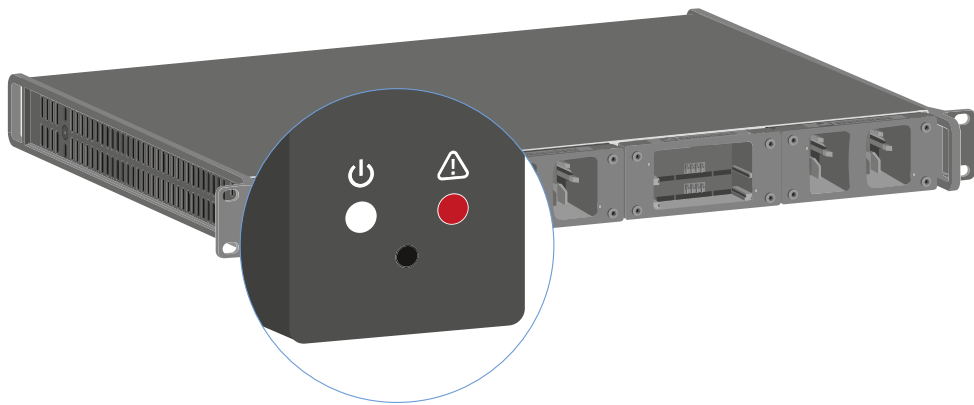

## Meaning of the LEDs

You can read the following information from the LEDs on the L 6000 charger and the LM 6060, LM 6061, LM 6062 and LM 6070 charging modules:

### L 6000 status LEDs

The L 6000 charger has two status LEDs on the front of the device to the left.



|   |  |
|---|--|
|   | White LED <b>flashing</b> >> device is starting or firmware is being updated                     |
|   | White LED <b>illuminated</b> >> device is ready for operation                                    |
|   | Red LED <b>flashing</b> >> fan is damaged  |
|   | Red LED <b>illuminated</b> >> device is too hot or too cold and the charging process was stopped |

### LM 6060 | LM 6061 | LM 6062 | LM 6070 status LEDs

The LM 6060, LM 6061, LM 6062 and LM 6070 modules each have two charging slots. Next to each charging slot, there is a status LED that displays the following status information:



|   |   |
|---|---|
|  | <b>Flashing red</b> >> the charging slot or rechargeable battery is too hot or too cold and the charging process was stopped. |
|---|---|



**Lights up red** >> the rechargeable battery is defective.



**Flashing yellow** >> the rechargeable battery is being regenerated.



**Lights up yellow** >> the rechargeable battery is being charged. Charge level **0% to 80%**



**Flashing green** >> the rechargeable battery is being charged. Charge level **81% to 96%**



**Lights up green** >> the rechargeable battery is fully charged. Charge level **100%**

#### **LM 6060, LM 6061, LM 6062 and LM 6070 status LEDs in storage mode**

If you are operating the L 6000 charger in **storage mode** via **WSM**, the meaning of the status indicators changes. You can find more information under [Preparing rechargeable batteries for storage \(storage mode\)](#).



## Preparing rechargeable batteries for storage (storage mode)

If you are not using the rechargeable batteries for a longer period of time and therefore want to store them, the rechargeable batteries should have a charge of approx. 70%.

You can set this level using the **storage mode** from the Sennheiser Wireless Systems Manager (WSM) software.

- ▶ To do so, connect the L 6000 charger to a network (see [Connecting the L 6000 to a network](#)) and establish the connection with the WSM software.

**i** For more information about controlling devices via the **Sennheiser Wireless Systems Manager** (WSM) software, refer to the instruction manual for the software. You can download the software here: [sennheiser.com/wsm](https://sennheiser.com/wsm)

### Meaning of the status LEDs in storage mode

In **storage mode**, the status LEDs next to the individual charging slots show the following status information:



**Flashing green/red** >> rechargeable battery not inserted.

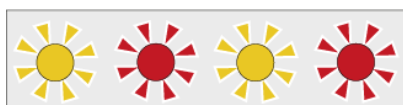

**Flashing yellow/red** >> the rechargeable battery is being charged or discharged to 70%.

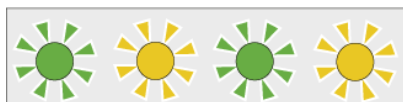

**Flashing green/yellow** >> the rechargeable battery has reached the storage charge level of 70%.



## Resetting settings (factory reset)

To reset the L 6000 charger settings to the factory settings:

- ▶ Use a pointed object to press the Reset button on the front of the L 6000 charger.
- ✓ The settings are reset to the factory settings.

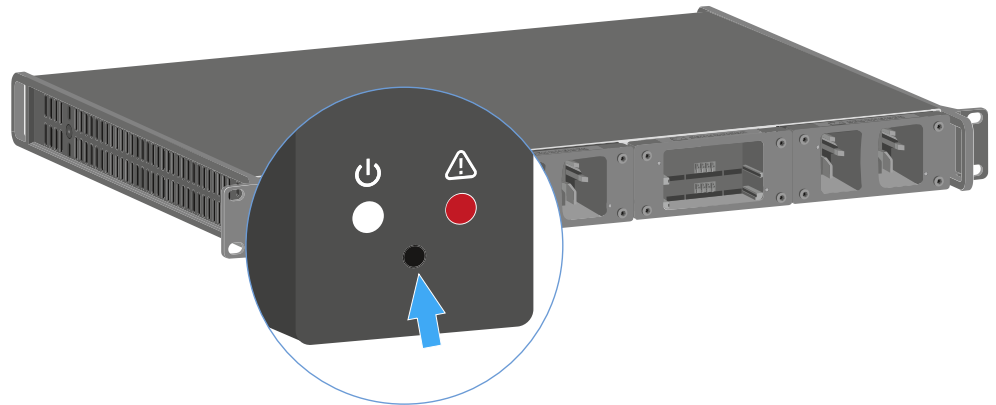



## Updating the firmware

You can update the firmware for the L 6000 charger using the Sennheiser **Wireless Systems Manager** (WSM) software.

- ▶ To do so, connect the L 6000 charger to a network (see [Connecting the L 6000 to a network](#)) and establish the connection with the WSM software.

**i** For more information about controlling devices via the **Sennheiser Wireless Systems Manager** (WSM) software, refer to the instruction manual for the software. You can download the software here: [sennheiser.com/wsm](https://sennheiser.com/wsm)

**i** You can find the **latest firmware** on the Digital 6000 product page or in the Sennheiser website's download area:  
[sennheiser.com/digital-6000](https://sennheiser.com/digital-6000)  
[sennheiser.com/download](https://sennheiser.com/download)



## Operating the L 6000 via a network

You can use the Sennheiser **Wireless Systems Manager** software to operate the charger via a network connection.

- ▶ To do so, connect the L 6000 charger to a network (see [Connecting the L 6000 to a network](#)) and establish the connection with the WSM software.

**i** For more information about controlling devices via the **Sennheiser Wireless Systems Manager** (WSM) software, refer to the instruction manual for the software. You can download the software here: [sennheiser.com/wsm](https://sennheiser.com/wsm)

You can perform the following actions using WSM:

- Update the L 6000 charger firmware
- Prepare rechargeable batteries for storage (see [Preparing rechargeable batteries for storage \(storage mode\)](#)).



## Cleaning and maintenance

Note the following information when cleaning and maintaining products of the Spectera series.

### NOTICE



#### Liquids can damage the electronics of the product

Liquids entering the product housing can cause a short-circuit and damage the electronics.

- ▶ Keep all liquids away from the products.
- ▶ Do not use any solvents or cleansing agents.
- ▶ Disconnect the mains-operated products from the power supply system and remove rechargeable batteries and batteries (if present) before you begin cleaning.
- ▶ Clean all products only with a soft, dry cloth.

- ▶ Note the special cleaning instructions below for the following products.

#### Replacing the Base Stations fan filter

- ▶ Check the filter from time to time and replace it if necessary. See [Changing the fan filter](#).

#### Cleaning the L 70 USB and CHG 70N chargers

- ▶ Remove all rechargeable batteries from the charging slots.
- ▶ Disconnect the charger from the power supply system before cleaning.
- ▶ Clean the product with a dry cloth.
- ▶ In addition, use a brush to remove dust from the charging slots.
- ▶ Clean the charging contacts from time to time with a cotton swab, for instance.



## Instruction manual

Detailed description of the WebUI navigation and configuration.

**i** Please navigate to the desired chapters by clicking on the related information.

## Getting started

Start your basic configuration with the recommended steps.

**i** If the Base Station IP is used via LinkDesk at the same time, the control buttons in the WebUI are deactivated. In this case, the user can monitor, but can no longer intervene actively.

When setting up the WebUI for the first time, we recommend following these first steps to successfully configure the system from the outset:

- [Identifying Base Station via IP](#)
- [Claiming single device \(WebUI\)](#)
- [Activating a license \(WebUI\)](#)
- [Enabling/disabling data collection](#)
- [Configuring RF channels](#)
- [Assigning an antenna to an RF channel](#)
- [Scanning the RF frequency](#)
- [Pairing/unpairing mobile devices](#)
- [Selecting the default audio input/output source](#)
- [Selecting audio link mode \(Mic/Line\)](#)
- [Selecting audio link mode \(IEM\)](#)
- [Assigning an RF channel](#)
- [Selecting the Mic/Line input](#)

**i** Operational data is collected to continuously improve the stability and functionality of Spectera. The data is pseudonymized to ensure there is no direct personal reference. Tracking can be disabled in the settings (see chapter [Enabling/disabling data collection](#)).



- i** If the connection to the device is lost (no power supply or no network connection), the live status will be displayed based on an error message.

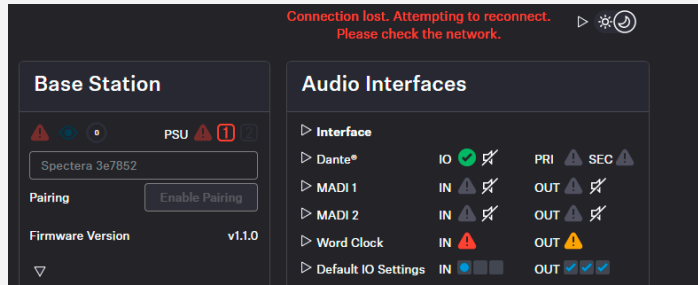

## Identifying Base Station via IP

In order to add a Base Station, its IP address is required.

You can read the IP address on the display of the device.

### To identify the IP of your Base Station:

- ▶ On the Base Station, rotate the jog-dial and navigate to the menu **Network**.
- ▶ Press the jog-dial to enter the menu.
- ✓ The network data will be displayed.

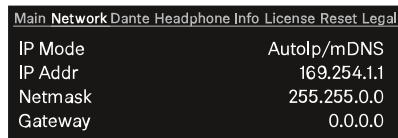

- ▶ Note the displayed IP of your device.

✓ The IP address of your Base Station has been identified.



## Claiming single device (WebUI)

Instructions for claiming a single device in Spectera WebUI.

To claim your Base Station:

- ▶ Enter the following URL into your browser: `https://deviceIP/specterawebui/index.html`

**i** Since the certificate is unknown to your browser, a security warning is displayed the first time you run the application. The security warning depends on the browser you are using.

- ▶ Depending on your browser, click on **Advanced** and then on:
  - **Continue to localhost (unsafe)** (Microsoft Edge)
  - **Proceed to localhost (unsafe)** (Google Chrome)
  - **Accept the Risk and Continue** (Firefox)
  - or similar (other browsers).
- ✓ The WebUI displays the following options depending on the state of the device:
  - If the device is in a factory default state and the original password is still assigned, it will be automatically detected and applied. Next, a new password has to be set:

If the device was previously claimed by another Sennheiser LinkDesk or Spectera WebUI instance, the previously set password must be entered:

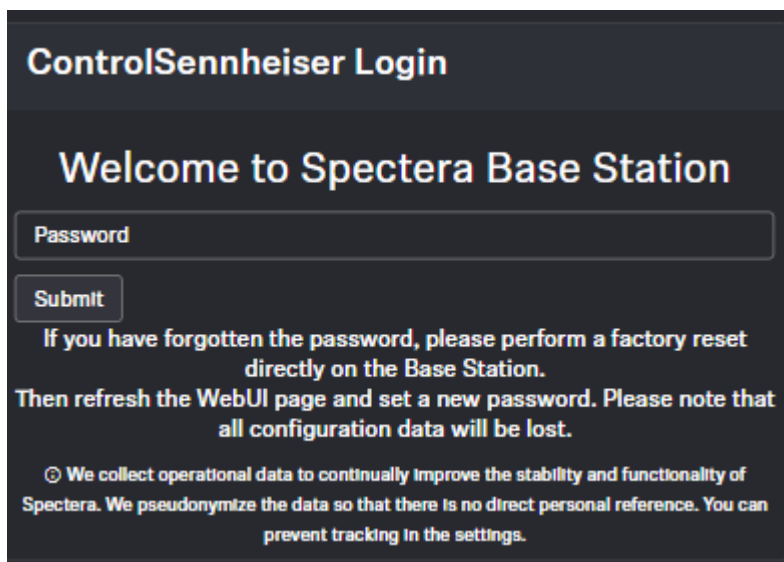

**i** If you cannot remember the previously set password, please perform a factory reset of the device. After the reset, the default password for Spectera will be automatically applied by the software.

- ▶ Set a new device password (if you are logging in for the first time) or enter the password you have already assigned for authentication (if you have already logged in).
- ▶ Click on **Submit**.

✓ Your Base Station has been claimed successfully.



## Activating a license (WebUI)

Under Entitlement, you can enter and activate the current license for the frequency spectrum.

- i** The purchased license (included in the product) is only valid for the region for which the product was designed and approved. The license may not be used in other regions.

### NOTICE



#### License activation requires a direct Internet connection to the device

In order to activate the Base Station using the 18-digit license code, a direct Internet connection is required.

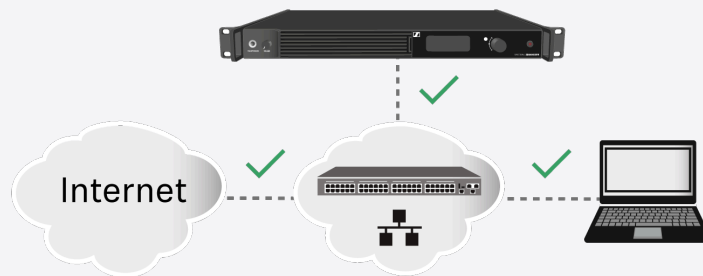

- ▶ Please connect your Base Station directly to a network with Internet access via a switch or router. For more information, refer to the chapter [Connecting to a network](#).
- ▶ Direct connections via laptop etc. are not supported for activation!

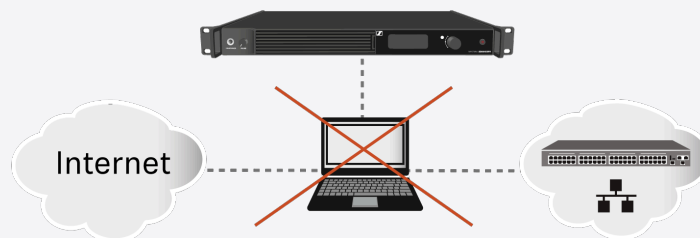

- ▶ The Internet is only required once for activation.

When you start the device for the first time, your license key is requested.

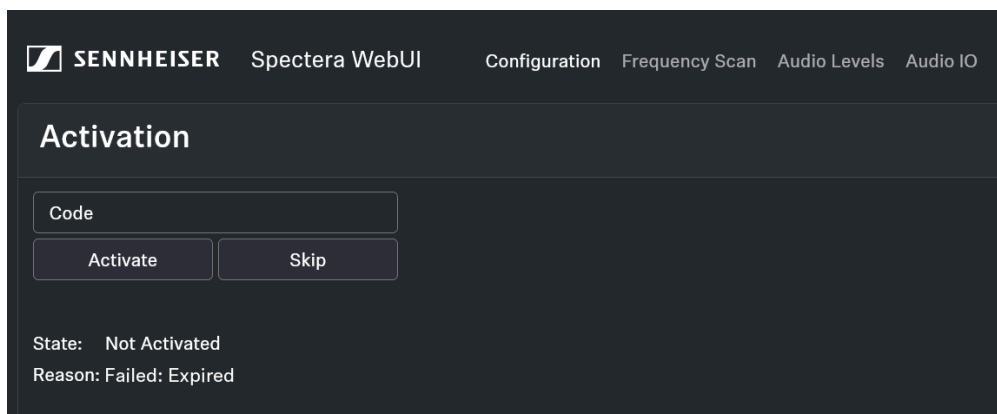

**To activate the license:**

- ▶ Enter the acquired license and click on **Activate** or on **Skip** to proceed with activation later.

✓ Your license has been activated.



## Enabling/disabling data collection

Spectera collects operational data to enhance stability and functionality.

The data is pseudonymized to ensure there is no direct personal reference.

### To enable/disable data collection:

- ▶ On the start page, navigate to the top navigation at the top right.
- ▶ Click on the triangle to expand the settings.

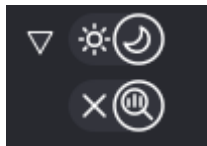

- ▶ Click on:
  - the X to stop data collection
  - the magnifying glass to enable data collection.

✓ Data collection has been enabled/disabled.



## Configuring RF channels



Here you can find out how to configure the RF channel correctly from the outset.

**i** The current local permissions are displayed when the frequency is selected.

To configure an RF channel:

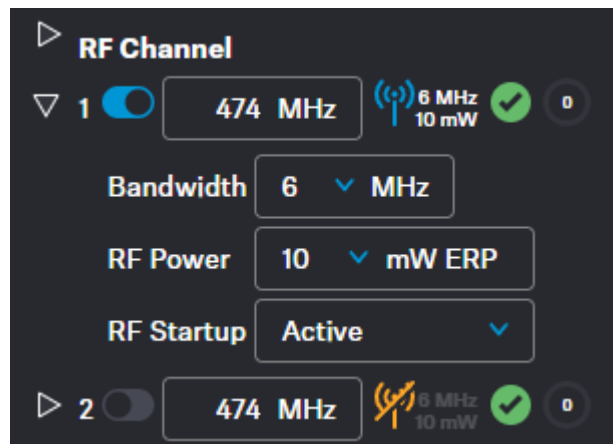
- ▶ In the top bar, navigate to **Configuration > RF Configuration**.
- ▶ For channel RF1, enter the frequency under **1** and confirm with **ENTER**.



- ▶ Next, select the **Bandwidth** and the **RF Power** for your location.
  - ✓ The applicability of your settings is indicated by an icon:
    -  green: applicable
    -  red: not applicable
- ▶ Under **RF Startup**, select the mute option for the configured RF channel:
  - Active
  - Muted
  - Last state = When switching on or leaving standby mode, the last used RF state is restored
- ✓ The RF Channel has been assigned to the operating antenna.

✓ The RF Channel has been configured.



## Assigning an antenna to an RF channel

You can choose between up to four connected antennas to assign them to your two possible RF channels.

**i** For additional reliability in terms of redundancy or to extend your range, you can assign up to four antennas per channel and use them simultaneously.

The antennas can be assigned and unassigned, e.g. to perform an RF scan or to switch between the configured RF channels.

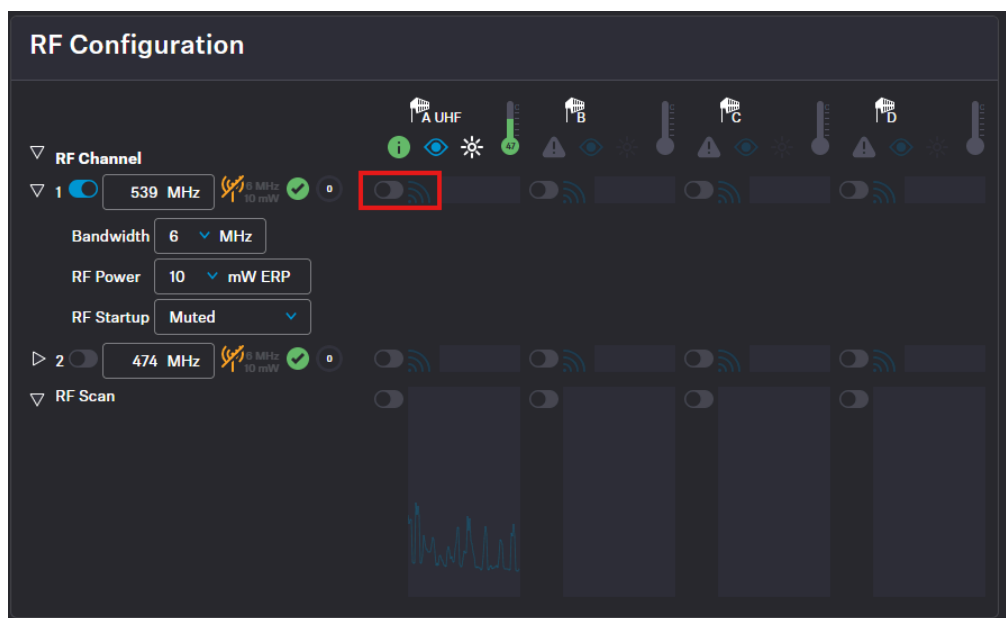

To assign an antenna for an RF channel:

- ▶ In the top bar, navigate to **Configuration > RF Configuration**.
- ▶ In your RF channel row, click on the toggle switch next to the utilization and interference icon .



- ✓ The toggle switch turns blue . The antenna has been assigned to the RF channel and any potential interference is indicated by the icon.

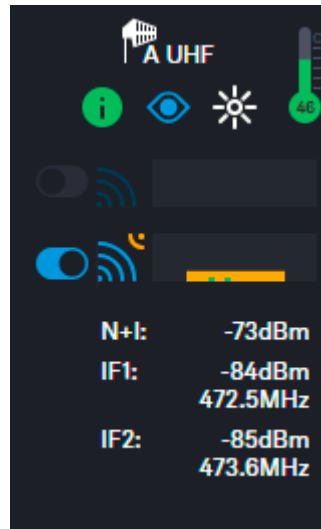

- ✓ The antenna has been assigned to a specific RF channel.



## Scanning the RF frequency

You can run a frequency scan to check the current frequency situation in your surrounding area.

The frequency scan provides an overview of the frequency situation in your location. You can save the antenna configuration as a .csv info file. This file can be used as a backup file to recapitulate your settings or as local frequency information for your specific environment. You can scan the frequencies of all antennas connected to the Base Station.

The scan can be initiated:

- via the [RF configuration](#) tab to see a small extract without any details or
- via the [Frequency Scan](#) tab for a detailed overview of the frequency situation.

The scan results will be displayed in two different curves:

- **Peak** (red) = Maximum value
- **RMS** (blue) = Average power or strength

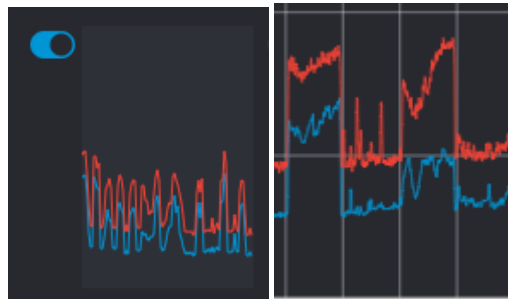

**i** Please note that the antenna must not be assigned to an RF channel before scanning (see [Assigning an antenna to an RF channel](#)).

### To scan the RF frequency via the RF configuration tab:

- ▶ In the top bar, navigate to **Configuration > RF Configuration**.
- ✓ Under the **RF Scan** drop-down menu, there are four toggle switches that enable and disable the scan function for each connected antenna.

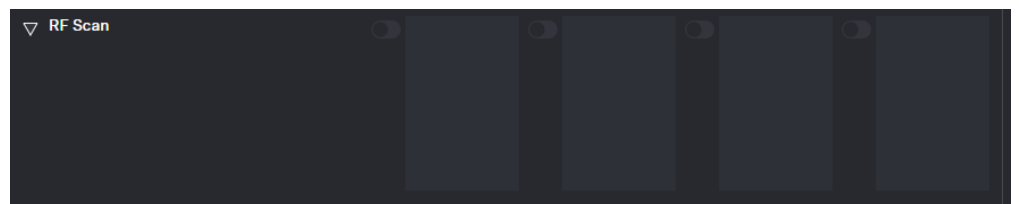

- ▶ Click on the toggle switch of the antenna to be scanned in order to start an immediate scan.



- ✓ The square is highlighted with a blue dot and the scan result is displayed in a small frequency curve after approx. 5 seconds.

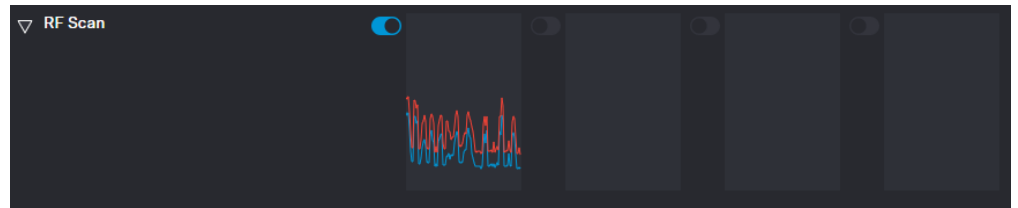

- ▶ In order to view the results,
  - click on the small frequency icon or
  - navigate to **Frequency Scan** in the top bar.

To scan the RF frequency via the Frequency Scan tab:

- ▶ In the top bar, navigate to the tab **Frequency Scan**.

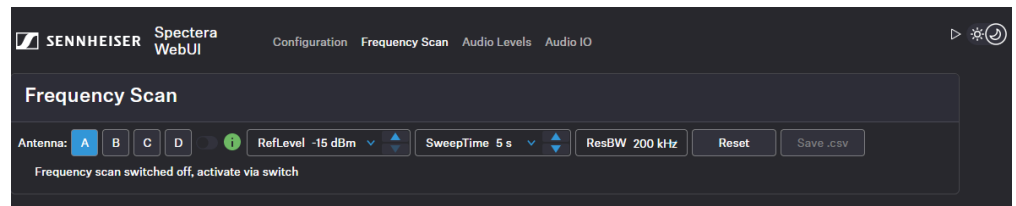

- ▶ Select your antenna to be scanned and adjust your desired settings.
- ▶ Switch on the toggle to start the scan.



- ✓ The frequency scan is started and the result is displayed in a detailed frequency diagram. Supported frequency ranges are shown in green and unsupported ranges in gray.



#### To reset a scan:

- ▶ Click on **Reset**.
- ✓ The current scan will be reset.

#### To save the scan results as `.csv` :

- ▶ Click on **Save.csv**.
- ✓ The antenna configuration has been downloaded locally to your computer as a `.csv` file.

✓ The frequency of your connected antenna has been scanned.



## Pairing/unpairing mobile devices

In the WebUI, you can pair up to 128 mobile devices to a Base Station within one RF channel.

Mobile devices can only be paired and operated with one Base Station at a time. If a mobile device is to be used with another Base Station, it must first be paired again.

**i** Please unmute at least one RF channel before pairing if this was not done automatically.

### To pair a mobile device:

- ▶ In the top bar, navigate to **Configuration > Base Station**.
- ▶ Click on **Enable Pairing**.
  - ✓ The Base Station starts the pairing process for 300 seconds.
- ▶ Switch on your mobile device and activate **Pairing Mode** if it has not been activated automatically ([Switching the SEK on and off](#)).
  - ✓ After a few seconds, the available mobile devices are displayed in the list below under **Mobile Devices**. A verification PIN is displayed on the mobile device and in the WebUI.

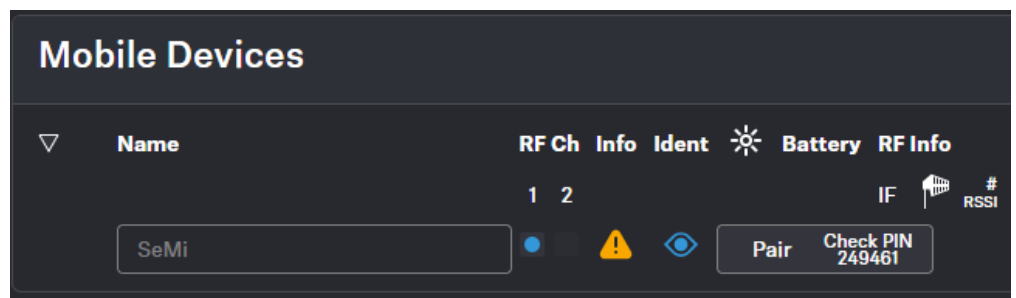

- ▶ Verify the PIN on the mobile device and click on **Pair**.
  - ✓ The mobile device has been paired successfully. The device state color changes to:



green (successfully paired)



gray (assigned RF channel not on air)



yellow (firmware mismatch) or



red (unconnected, no RF channel selected, not available)



**To unpair a mobile device:**

**i** To unpair a paired device, the audio links must first be deactivated.

- ▶ In the top bar, navigate to **Configuration > Mobile Devices**.
- ▶ Click on the button **Unpair > Confirm** in the line of the mobile device to be unpaired.
  - ✓ The mobile device has been successfully unpaired.

✓ The mobile devices have been successfully paired/unpaired.



## Selecting the default audio input/output source

You can select the default source for the audio input and output of your audio interface.

To select the default input interface:

- ▶ In the top bar, navigate to **Configuration RF > Audio Interfaces**.
- ▶ Select the input interface under **Default IO Settings**.
  - ✓ The default input interface has been selected.

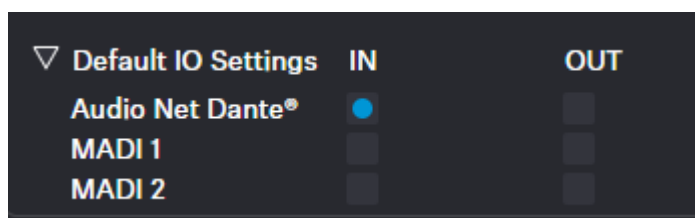

To select the clock source output:

- ▶ Select the desired setting for the clock source under:
  - MADI 1
  - MADI 2
  - Word Clock BNC
- ✓ The clock source output has been selected.

✓ The audio interfaces have been selected.









## Selecting audio link mode (Mic/Line)

You can select the audio mode for your Mic/Line link.

**i** Please note that the bandwidth utilization varies depending on the link mode.

The following modes are available:





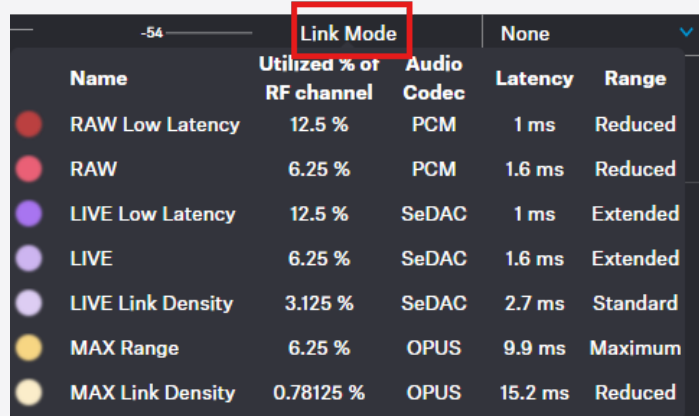

-  Max Range
-  Max Link Density
-  Live Link Density
-  LIVE
-  Live Low Latency
-  RAW
-  RAW Live Low Latency

To select the audio mode:

- ▶ In the top bar, navigate to **Configuration > Mobile Devices > Mic Settings**.
- ▶ Select the audio mode from the drop-down list **Link Mode**.

**i** Hover your mouse over the word **Link Mode** to display a tabular listing of possible modes.



| Name  | Utilized % of RF channel | Audio Codec | Latency | Range    |
|---|--------------------------|-------------|---------|----------|
|  RAW Low Latency   | 12.5 %                   | PCM         | 1 ms    | Reduced  |
|  RAW               | 6.25 %                   | PCM         | 1.6 ms  | Reduced  |
|  LIVE Low Latency  | 12.5 %                   | SeDAC       | 1 ms    | Extended |
|  LIVE              | 6.25 %                   | SeDAC       | 1.6 ms  | Extended |
|  LIVE Link Density | 3.125 %                  | SeDAC       | 2.7 ms  | Standard |
|  MAX Range         | 6.25 %                   | OPUS        | 9.9 ms  | Maximum  |
|  MAX Link Density  | 0.78125 %                | OPUS        | 15.2 ms | Reduced  |

 The audio mode has been selected.









## Selecting audio link mode (IEM)

You can select the audio mode for your IEM link.

**i** Please note that the bandwidth utilization varies depending on the link mode.

The following modes are available:

-  Max Range
-  Max Link Density
-  Live Link Density Range
-  Live Link Density Range
-  Live Low Latency
-  Live Ultra Low Latency

To select the audio mode:

- ▶ In the top bar, navigate to **Configuration > Mobile Devices > IEM Settings**.
- ▶ Select the audio mode from the drop-down list **Link Mode**.

**i** Hover your mouse over the word **Link Mode** to display a tabular listing of possible modes.

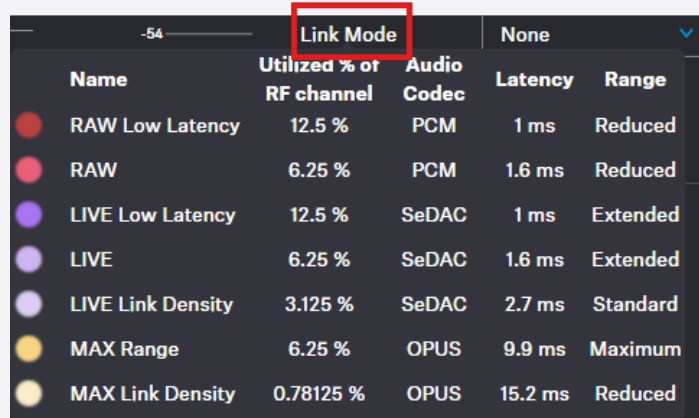

| Name              | Utilized % of RF channel | Audio Codec | Latency | Range    |
|-------------------|--------------------------|-------------|---------|----------|
| RAW Low Latency   | 12.5 %                   | PCM         | 1 ms    | Reduced  |
| RAW               | 6.25 %                   | PCM         | 1.6 ms  | Reduced  |
| LIVE Low Latency  | 12.5 %                   | SeDAC       | 1 ms    | Extended |
| LIVE              | 6.25 %                   | SeDAC       | 1.6 ms  | Extended |
| LIVE Link Density | 3.125 %                  | SeDAC       | 2.7 ms  | Standard |
| MAX Range         | 6.25 %                   | OPUS        | 9.9 ms  | Maximum  |
| MAX Link Density  | 0.78125 %                | OPUS        | 15.2 ms | Reduced  |

✓ The audio mode has been selected.



## Assigning an RF channel

You can assign a configured RF channel to your mobile device.

To assign the RF channel:

- ▶ In the top bar, navigate to **Configuration > Mobile Devices**.
- ▶ Select your configured channel under **RF Ch**.

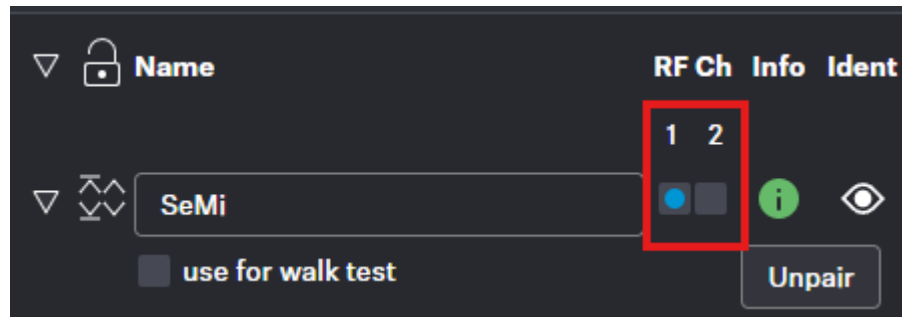

**i** To change the RF channel, you must first deactivate the audio Link Mode and the audio Channels.

- ▶ Enable the toggle switch of the configured RF channel.

✓ The RF channel has been assigned to your mobile device.



## Selecting the Mic/Line input

You can select the audio input as the signal source for your Mic/Line link.

**i** For a smooth system configuration, we recommend first selecting the link modes and afterwards assigning the channels:

- Selecting audio link mode (Mic/Line)
- Selecting audio link mode (IEM)
- [Adding/removing an audio channel \(Mic/Line\)](#)
- [Selecting an audio channel \(IEM link\)](#)
- [Selecting the IEM audio interface](#)

**i** You can route audio links to several channels. Routing can be performed easily via the routing matrix (see [Audio inputs and outputs](#)).

The following input signals are available:

- Auto (unknown)
- Mic
- Line

**i** The automatic mic/line detection is based on power consumption and is optimized for use with Sennheiser microphones. Because third-party microphones vary widely, reliable detection cannot always be ensured.

### To choose the audio input:

- ▶ In the top bar, navigate to **Configuration > Mobile Devices > Mic Settings**.
- ▶ Select the audio input from the drop-down list **Mic/Line**.

✓ The audio input has been selected.



## Configuration

Under Configuration, you can set the essential settings for the RF channel, antenna, Base Station and mobile devices.

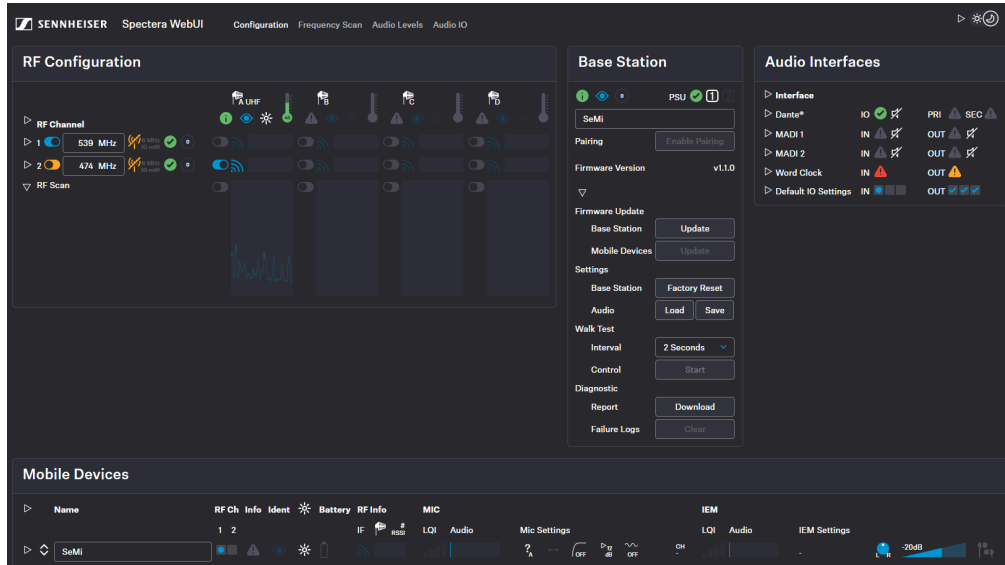

**i** Please navigate to the desired chapters by clicking on the related information.

## RF configuration

Here you can set up your RF channel and check the status of local permissions, your connected antenna, and any potential frequency interference in the surrounding area.

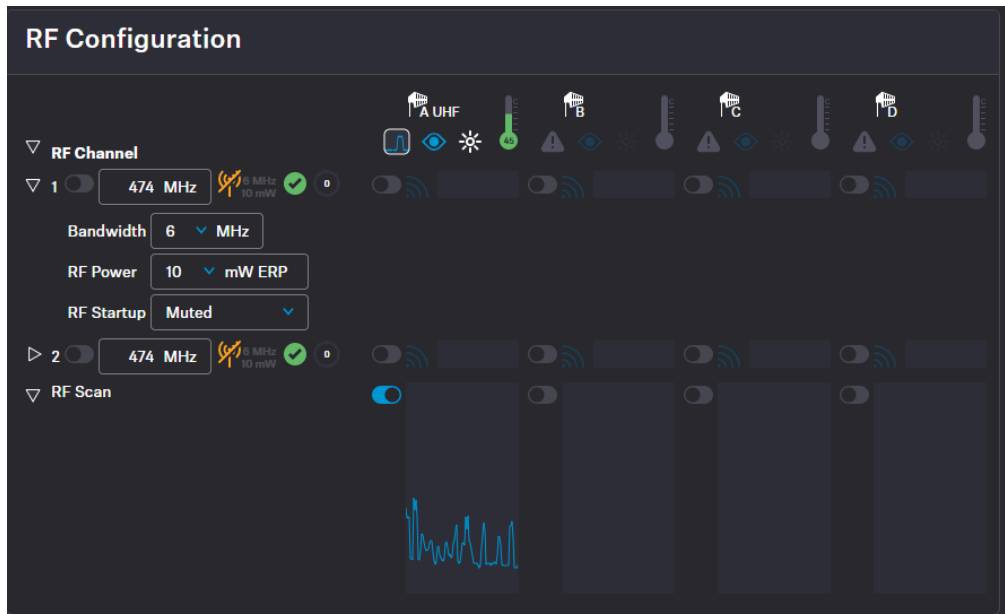





## RF Channel

- Display of two possible configurable RF channels **RfC 1** and **RfC 2**
- Display of the antenna (A-D) assigned to the RF channel

## Frequency

- Settings for frequency of the RF channel
- The input is accepted via the **ENTER** key

**i** The input cannot be accepted by switching with **TAB**

-  Status indication of the RF channel with current settings
- Permission indication for local country based on RF channel settings
  -  Valid properties acc. to the license and local regulations
  -  Invalid properties acc. to the license and local regulations



**i** The frequency and bandwidth must comply with local regulations.

-  Capacity utilization of the entire RF bandwidth in %

## Bandwidth

- Settings for bandwidth of the RF channel



**i** The input cannot be accepted by switching with **TAB**

**i** The frequency and bandwidth must comply with local regulations. Permission is displayed via the icons  (valid) and  (invalid).



## RF Power













- Setting for the transition power of the transmitter

**i** The frequency and bandwidth must comply with local regulations. Permission is displayed via the icons  (valid) and  (invalid).

## RF Startup

- Settings for the first RF start after switching off the device or when waking up the device after it has been in standby mode.

## Antenna

-  Display of available antennas (A-D)
-  Readiness status of the RF channel
  -  green (successfully paired and ready)
  -  gray (assigned RF channel not on air)
  -  yellow (high temperature or packet jitter)
  -  red (error, for example: PoE malfunction, critical temperature)
  -  red flashing (unconnected: antenna is configured but not connected)
-  Identification button for configured antenna (flashes white 3x)
-  LED brightness of the antenna LED (off, dim, standard, bright)
-  Current antenna temperature (switch between Celsius and Fahrenheit)
-  Indication for active RF
-  Frequency indication without any interference
-  Frequency indication with interference in the surrounding area

## Configuring RF channels

Here you can find out how to configure the RF channel correctly from the outset.





**i** The current local permissions are displayed when the frequency is selected.

**To configure an RF channel:**

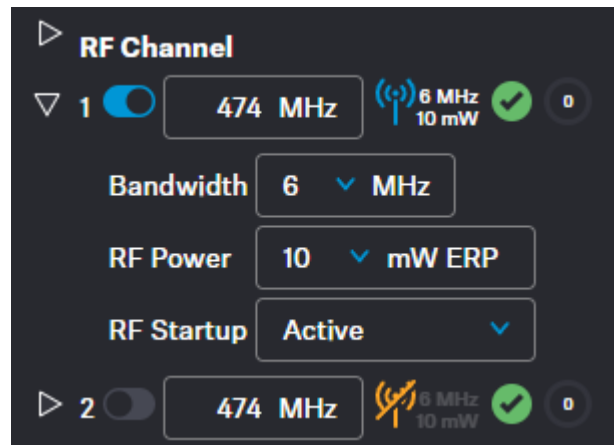
- ▶ In the top bar, navigate to **Configuration > RF Configuration**.
- ▶ For channel RF1, enter the frequency under **1** and confirm with **ENTER**.



- ▶ Next, select the **Bandwidth** and the **RF Power** for your location.
  - ✓ The applicability of your settings is indicated by an icon:
    -  green: applicable
    -  red: not applicable
- ▶ Under **RF Startup**, select the mute option for the configured RF channel:
  - Active
  - Muted
  - Last state = When switching on or leaving standby mode, the last used RF state is restored
- ✓ The RF Channel has been assigned to the operating antenna.

✓ The RF Channel has been configured.



## Assigning an antenna to an RF channel

You can choose between up to four connected antennas to assign them to your two possible RF channels.

**i** For additional reliability in terms of redundancy or to extend your range, you can assign up to four antennas per channel and use them simultaneously.

The antennas can be assigned and unassigned, e.g. to perform an RF scan or to switch between the configured RF channels.

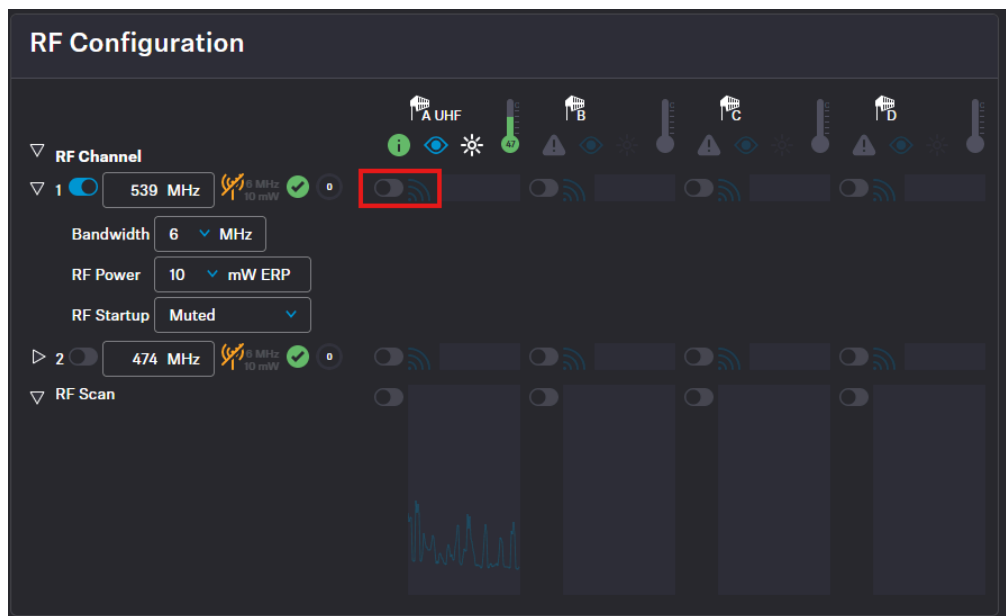

To assign an antenna for an RF channel:

- ▶ In the top bar, navigate to **Configuration > RF Configuration**.
- ▶ In your RF channel row, click on the toggle switch next to the utilization and interference icon .



- ✓ The toggle switch turns blue . The antenna has been assigned to the RF channel and any potential interference is indicated by the icon.

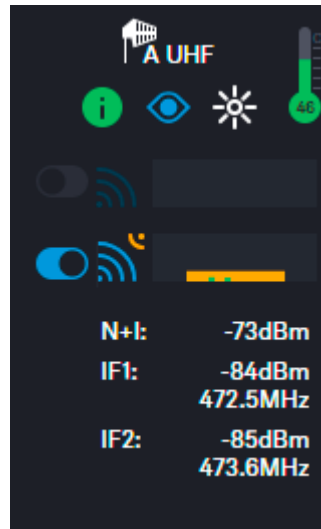

- ✓ The antenna has been assigned to a specific RF channel.



## Scanning the RF frequency

You can run a frequency scan to check the current frequency situation in your surrounding area.

The frequency scan provides an overview of the frequency situation in your location. You can save the antenna configuration as a .csv info file. This file can be used as a backup file to recapitulate your settings or as local frequency information for your specific environment. You can scan the frequencies of all antennas connected to the Base Station.

The scan can be initiated:

- via the **RF configuration** tab to see a small extract without any details or
- via the **Frequency Scan** tab for a detailed overview of the frequency situation.

The scan results will be displayed in two different curves:

- **Peak** (red) = Maximum value
- **RMS** (blue) = Average power or strength

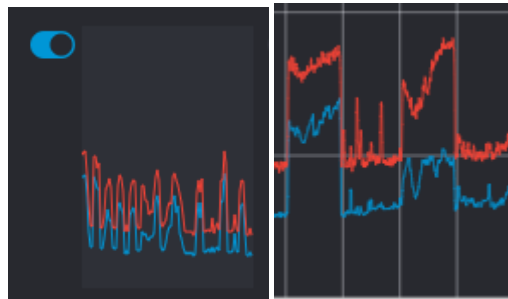

**i** Please note that the antenna must not be assigned to an RF channel before scanning (see **Assigning an antenna to an RF channel**).

### To scan the RF frequency via the RF configuration tab:

- ▶ In the top bar, navigate to **Configuration > RF Configuration**.
- ✓ Under the **RF Scan** drop-down menu, there are four toggle switches that enable and disable the scan function for each connected antenna.

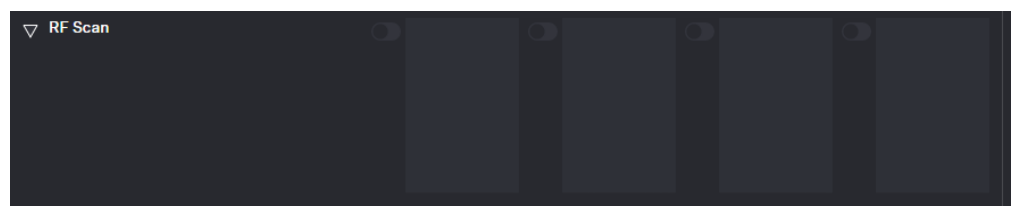

- ▶ Click on the toggle switch of the antenna to be scanned in order to start an immediate scan.



- ✓ The square is highlighted with a blue dot and the scan result is displayed in a small frequency curve after approx. 5 seconds.

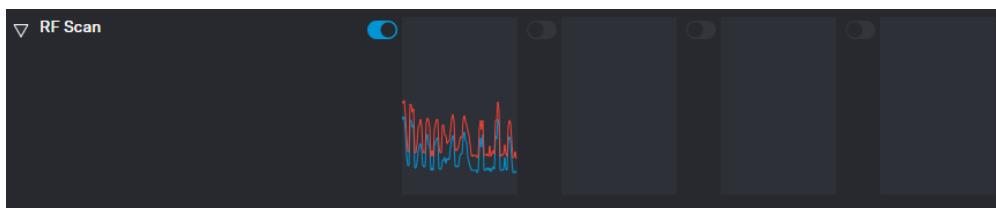

- ▶ In order to view the results,
  - click on the small frequency icon or
  - navigate to **Frequency Scan** in the top bar.

To scan the RF frequency via the Frequency Scan tab:

- ▶ In the top bar, navigate to the tab **Frequency Scan**.

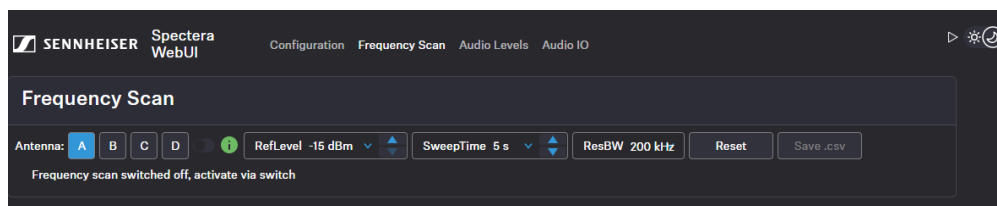

- ▶ Select your antenna to be scanned and adjust your desired settings.
- ▶ Switch on the toggle to start the scan.



- ✓ The frequency scan is started and the result is displayed in a detailed frequency diagram. Supported frequency ranges are shown in green and unsupported ranges in gray.

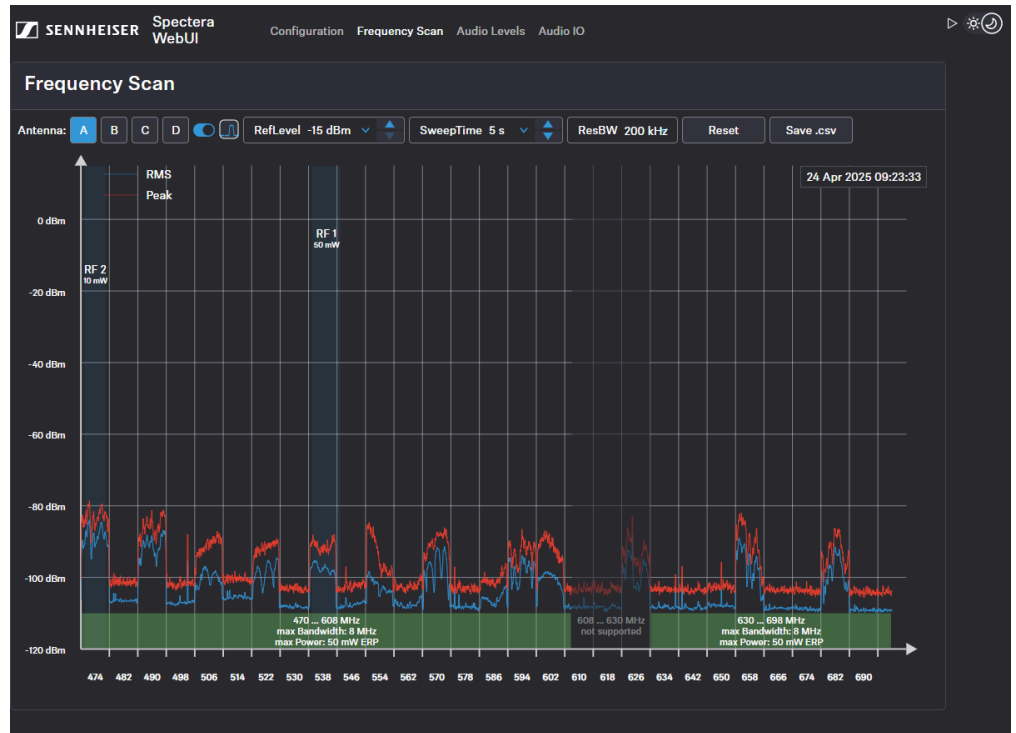

**To reset a scan:**

- ▶ Click on **Reset**.
- ✓ The current scan will be reset.

**To save the scan results as .csv :**

- ▶ Click on **Save.csv**.
- ✓ The antenna configuration has been downloaded locally to your computer as a .csv file.

✓ The frequency of your connected antenna has been scanned.



## Managing the AFTRCC e-key for 1G4 in the US only

Configure your Spectera system to use an e-key for compliant operation.

### Prerequisites

- Spectera Base Station
- DAD 1G4
- SEK 1G4
- Laptop
- Internet connection
- Bootstrapped and activated Spectera system
- Spectera US license (Zone 02)

### To set up the basics:

- ▶ Switch the Base Station on.
- ▶ Connect your laptop via network to the control port of the Base Station.
- ▶ Connect the DAD 1G4 to the Base Station.
- ▶ Get the IP address from the display.
- ▶ Start the WebUI in your browser by entering **https://deviceIP**.
- ▶ Log in to the WebUI.
  - ✔ You can see one 1G4 antenna connected, but it cannot be enabled (indicated by a red triangle).

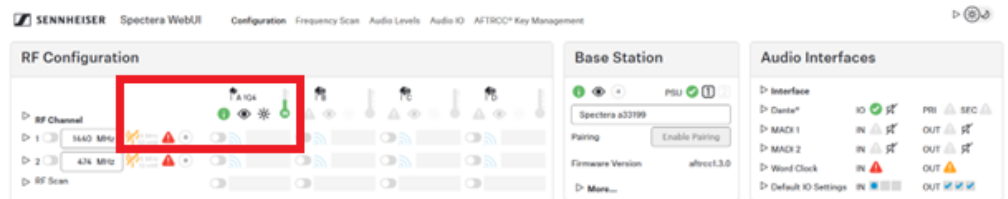

### To open the AFTRCC key management:

- ▶ Open the AFTRCC Key Management tab at the top.

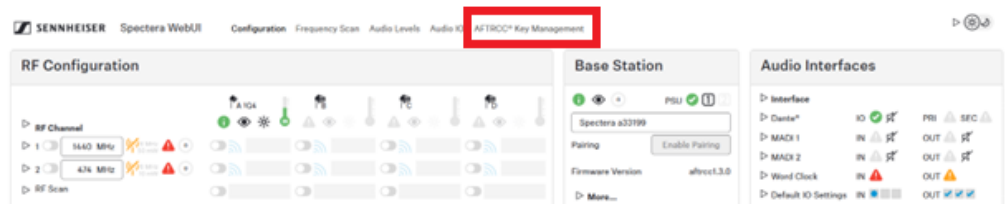



**i** This tab is only available with a licence zone 02 in the USA.

- ▶ Click on **Import** and select the e-key from your file system.

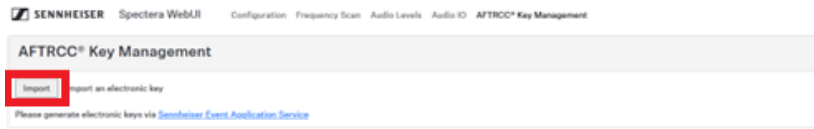

- ✓ A red triangle shows information about why it is not working.

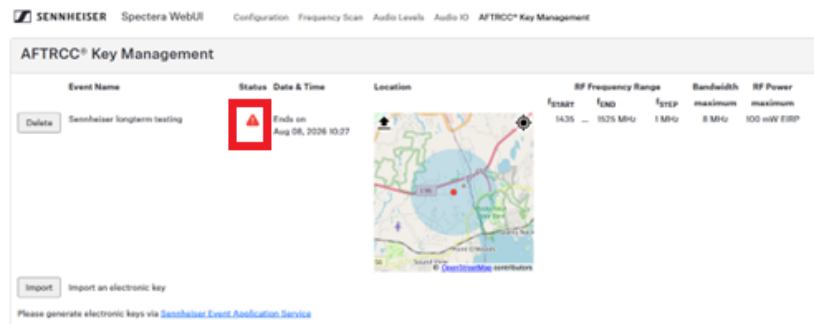

**Status** **Date & Time**

**Location**

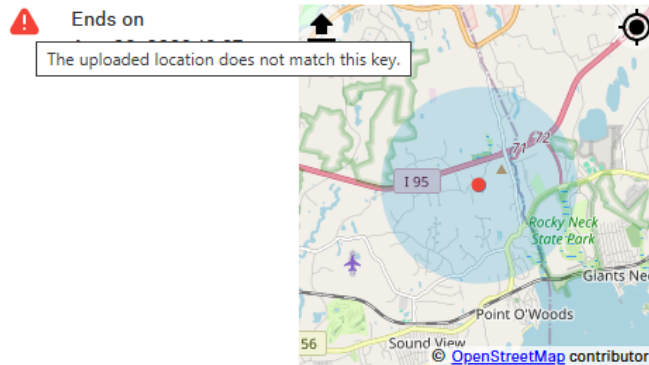

- ▶ Make sure that your Spectera system is connected to the Internet and can get the current valid time and date.  
The Base Station can maintain valid time and date for up to two weeks, when neither internet connection nor mains power is available.



**To update and upload the location:**

- ▶ Press the localization icon in the map.

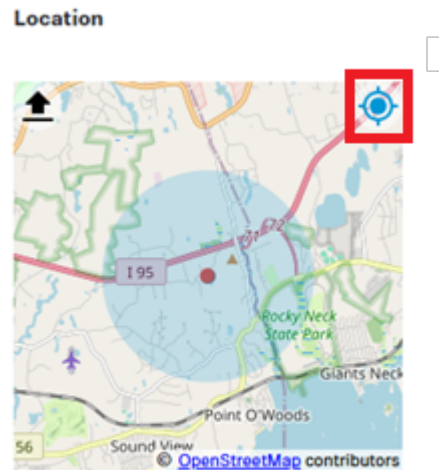

- ▶ If the system asks for access to the location service, grant it.

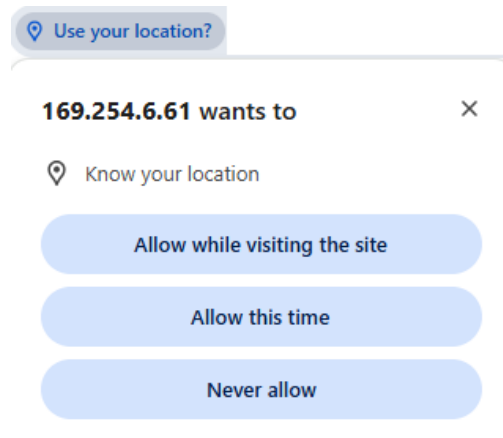

**i** Sometimes the browser localization needs some time after granting access to location service. You can press the localization icon again to improve accuracy.

- ▶ Upload your location by pressing the upload button in the map.



### Location

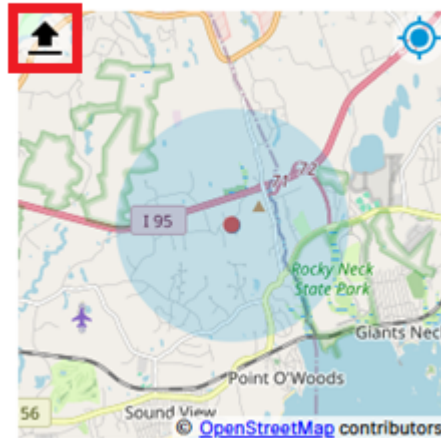

- ▶ Click the confirmation button. You hereby confirm, that the current shown location is correct.

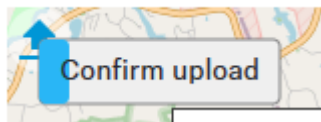

- ✔ The status changes to green, if all the necessary prerequisites are met (time, date and location).

SENNHEISER Spectera WebUI Configuration Frequency Scan Audio Levels Audio ID AFTRCC® Key Management

#### AFTRCC® Key Management

| Event Name   | Status | Date & Time                | Location | RF Frequency Range                                    | Bandwidth | RF Power    |
|--|--------|----------------------------|----------|---|-----------|-------------|
|  |        |                            |          | f <sub>START</sub> f <sub>END</sub> f <sub>STEP</sub> | maximum   | maximum     |
| <a href="#">Delete</a> Sennheiser longterm testing | ✔      | Ends on Aug 08, 2026 10:27 |          | 1435 ... 1525 MHz 1 MHz                               | 8 MHz     | 100 mW EIRP |

[Import](#) Import an electronic key

Please generate electronic keys via [Sennheiser Event Application Service](#)

### To configure and enable the RF channel:

- ▶ Open the Configuration tab at the top.
- ▶ Configure the frequency of the RF channel to one valid frequency as defined in the e-key.

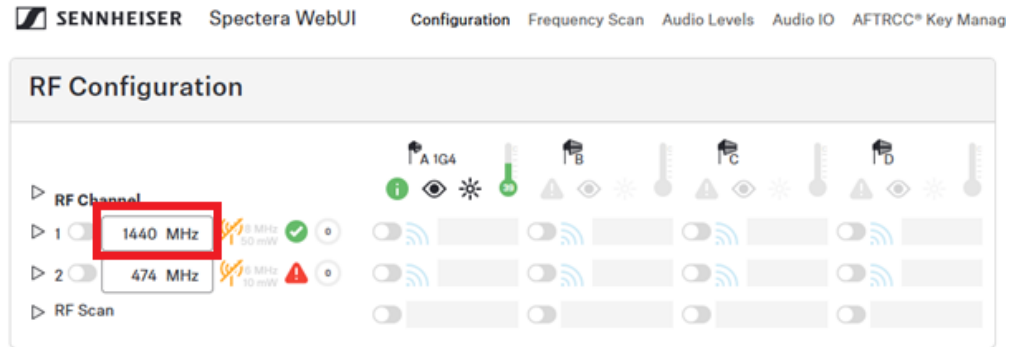

- ▶ Check if the RF channel can be used as configured.

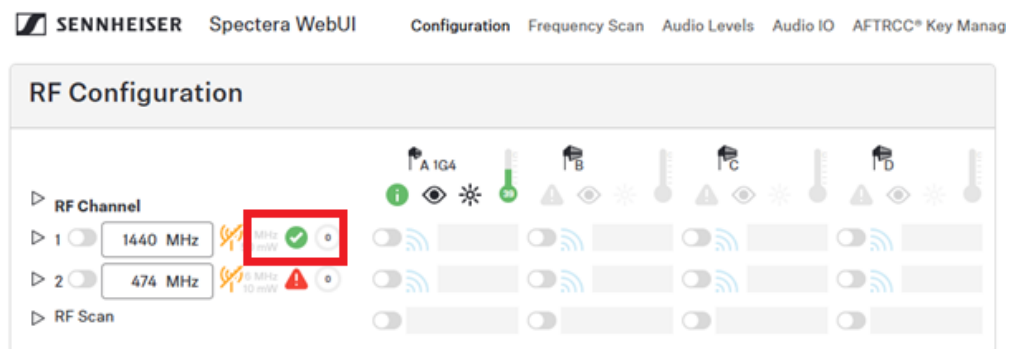

- ▶ Enable the antenna.

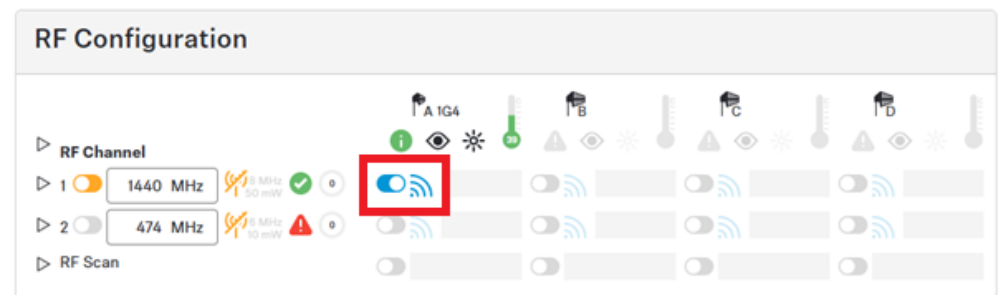

- ▶ Enable the RF channel.

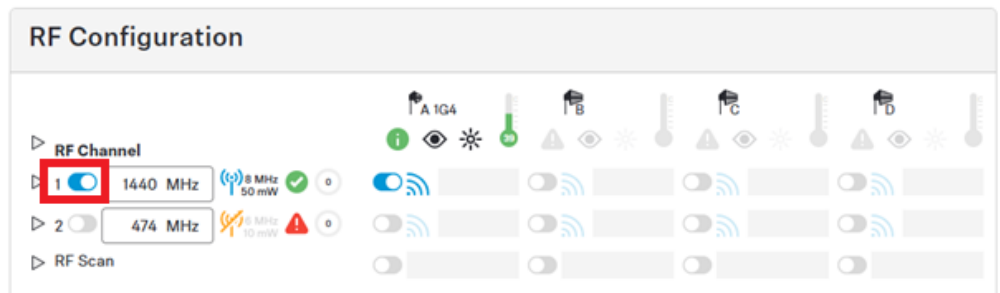

✓ The system is now working within the parameters of the e-key.





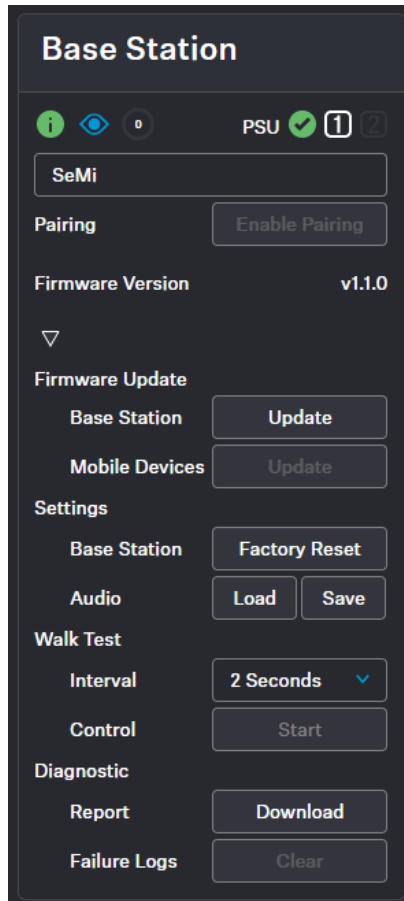

## Base Station

Here, you can check the basic settings of the Base Station and easily perform tasks such as firmware updates, walk tests, or restoring it to factory settings.



### General

-  Device state color
-  Identify button (see [Identifying the Base Station](#))
-  Indication for pending actions
-  Connection status and number of connected power supply units
- Name of your Base Station (see [Changing the device name](#))

### Enable Pairing

- Triggers the Pairing function of the Base Station for 300 sec. (see [Pairing/unpairing mobile devices](#))



## Firmware Update

- Base Station
  - Update service for the Base Station (see [Updating the firmware \(Base Station\)](#))
- Mobile Devices
  - Update service for mobile devices (see [Updating the firmware \(mobile devices\)](#))

## Settings

- Base Station
  - Factory Reset - resets the Base Station to the factory defaults (see [Resetting the Base Station](#))
- Audio
  - Saving/loading audio settings as `.json` file ([Saving/loading audio settings](#))

## Walk Test

- Interval: interval of the walk test (see [Performing a walk test](#))
- Control: Starting/Stopping the walk test

## Diagnostic

- **Report:** Provides archived support information of the product as a download.

**i** The automatically generated file contains basic information about the product and the last saved product configuration before a potential failure. In case of support, this file should be saved and sent to the support team.

- **Failure Logs:** Deletes all error messages saved under "Report" that occurred during runtime.

## Changing the device name

You can change the device name for your Base Station.

**i** For security reasons, please do not enter any sensitive personal data as the device name.



**To change the device name:**

- ▶ In the top bar, navigate to **Configuration > Base Station**.
- ▶ Edit the name under **Name** and confirm with **ENTER**.
  - ✓ The name is immediately transmitted to the Base Station and saved.

✓ The device name has been changed.



## Updating the firmware (Base Station)

The firmware version of the Base Station can be downloaded and updated manually.

The firmware version for the Base Station also includes the latest versions for the antennas and the mobile devices. While the antennas are updated automatically, the updates for the mobile devices must be started explicitly.

**i** Please download the latest firmware version for your Base Station under: [sennheiser.com/spectera-base-station](https://sennheiser.com/spectera-base-station).

### NOTICE



#### Data loss during firmware update

The audio transmission is interrupted during the firmware update of the Base Station, the antenna or the mobile device.

After the firmware update, the device is restarted automatically.

- ▶ Do not update the firmware during an active live audio transmission.

#### To update your Base Station firmware:

- ▶ In the top bar, navigate to **Configuration > Base Station**.
- ▶ Under **Firmware Update > Base Station** click on **Update**.
  - ✓ A new upload window opens.
- ▶ Select the manually downloaded `.sennpkg` file.
  - ✓ The firmware file has been selected. The firmware starts the update automatically. The update process is indicated by the current percentage value.

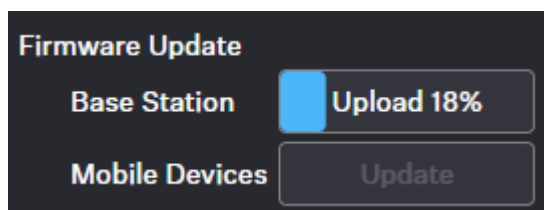

**i** After the successful update, the Base Station restarts and automatically begins the update on the connected antennas. Please refresh your browser after the entire update process.



✓ The firmware has been updated once the update is installed.



## Updating the firmware (mobile devices)

The update of the firmware version of mobile devices can be initiated using the Update button.

The latest firmware version for the mobile devices will be delivered with the latest firmware version of the Base Station. To update to a new version, the update process must be initialized individually.

**i** Please note that firmware versions are not backward compatible. The latest compatible version is included in the firmware update package for the Base Station.

### NOTICE



#### Data loss during firmware update

The audio transmission is interrupted during the firmware update of the Base Station, the antenna or the mobile device.

After the firmware update, the device is restarted automatically.

- ▶ Do not update the firmware during an active live audio transmission.

#### To update your mobile device firmware:

- ▶ In the top bar, navigate to **Configuration > Base Station**.
- ▶ Under **Firmware Update > Mobile Devices** click on **Update**.
- ✔ The update process will start automatically and show the progress as a percentage . After a successful update, the mobile device is restarted and paired automatically.

**i** The firmware update is a disruptive process. The mobile devices will update and reboot in sequence. This process will take roughly 20 seconds: during this time audio will be lost. Please stay in reach of the Base Station, do not remove the battery from the mobile devices during the process and do not close the application.

✔ The firmware has been updated.



## Resetting the Base Station

You can reset the Base Station to the factory settings remotely.

**i** You can also reset the Base Station to the factory settings directly via the device.

### NOTICE



#### Loss of data after resetting to factory settings

All settings are reset to the factory settings!

All devices will be unpaired and all audio routes will be deleted!

The user password will be reset!

The entitlement will remain.

- ▶ Make sure that no connections are being actively used at the time of the reset.

### To reset the Base Station remotely:

- ▶ In the top bar, navigate to **Configuration > Base Station**.
- ▶ Click on **Settings** and then on **Factory Reset**.
- ✓ A countdown timer will be displayed (highlighted in blue).

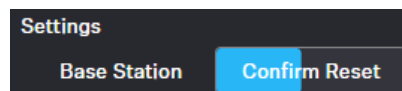

- ▶ Press **Confirm Reset** to confirm the factory reset.

- ✓ The Base Station has been reset. Upon re-login, you will be prompted to set a new password for the device.

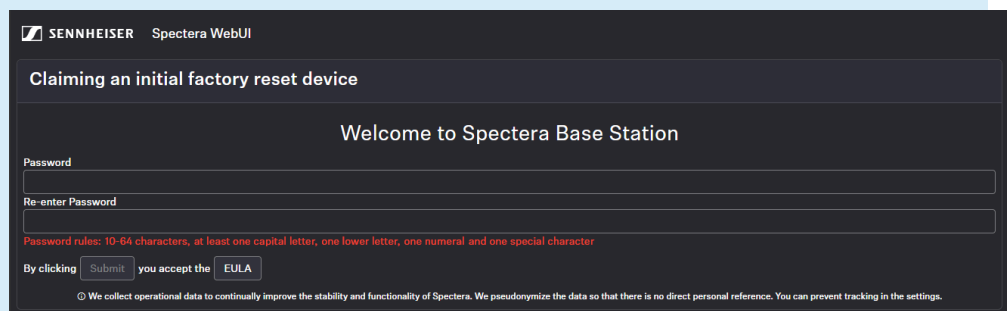



## Pairing/unpairing mobile devices

In the WebUI, you can pair up to 128 mobile devices to a Base Station within one RF channel.

Mobile devices can only be paired and operated with one Base Station at a time. If a mobile device is to be used with another Base Station, it must first be paired again.

**i** Please unmute at least one RF channel before pairing if this was not done automatically.

### To pair a mobile device:

- ▶ In the top bar, navigate to **Configuration > Base Station**.
- ▶ Click on **Enable Pairing**.
  - ✓ The Base Station starts the pairing process for 300 seconds.
- ▶ Switch on your mobile device and activate **Pairing Mode** if it has not been activated automatically ([Switching the SEK on and off](#)).
  - ✓ After a few seconds, the available mobile devices are displayed in the list below under **Mobile Devices**. A verification PIN is displayed on the mobile device and in the WebUI.

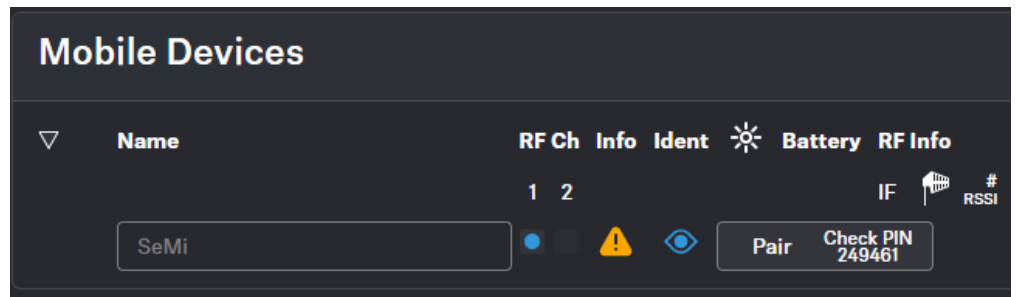

- ▶ Verify the PIN on the mobile device and click on **Pair**.
  - ✓ The mobile device has been paired successfully. The device state color changes to:



green (successfully paired)



gray (assigned RF channel not on air)



yellow (firmware mismatch) or



red (unconnected, no RF channel selected, not available)



**To unpair a mobile device:**

**i** To unpair a paired device, the audio links must first be deactivated.

- ▶ In the top bar, navigate to **Configuration > Mobile Devices**.
- ▶ Click on the button **Unpair > Confirm** in the line of the mobile device to be unpaired.
  - ✓ The mobile device has been successfully unpaired.

✓ The mobile devices have been successfully paired/unpaired.



## Identifying the Base Station

You can remotely identify your Base Station.

**To identify the Base Station:**

- ▶ In the top bar, navigate to **Configuration > Base Station**.
- ▶ Click on the  **Identify** icon.
  - ✓ The icon on the Base Station card flashes. The Base Station display shows "Identify".

✓ The Base Station has been identified.



## Saving/loading audio settings

You can save your audio settings and load them at a later time.

- i** In order to apply the audio settings, a familiar ID of the previously assigned mobile device is expected in connection with the hardware configuration of the Base Station described in this document. Unknown IDs of the mobile device or unknown hardware configurations will result in the settings not being accepted successfully.

The audio settings can be exported in a `.json` file.

### To save your audio settings:

- ▶ In the top bar, navigate to **Configuration > Base Station**.
- ▶ Under **Settings** click on **Save**.
  - ✓ Your audio settings have been exported as a `.json` file.

### To load your saved audio settings:

- ▶ In the top bar, navigate to **Configuration > Base Station**.
- ▶ Under **Settings** click on **Load**.
  - ✓ A new upload window opens.
- ▶ Select your saved file and click on **Open**.
  - ✓ Your audio settings file has been successfully loaded.

- ✓ The audio settings have been successfully saved/loaded.



## Performing a walk test

A walk test allows you to check the reception quality of your radio links within the operating environment.

The automatically generated data is used to provide an overview of the frequency behavior with the simulated devices and their configuration under the intended conditions. The result is represented as plain data in a `.json` file. The implementation of a graphical representation of the result is in planning.

You can specify the measurement interval of the walk test in seconds:

- 1
- 2
- 3
- 4
- 5
- 10
- 20
- 30

**i** If the total data rate is too high, individual values are omitted.

### To perform a walk test:

- ▶ Switch on the transmitter and the receiver of the radio link you want to check.
- ▶ In addition, switch on all other devices that you want to use in the operating environment.
- ▶ Navigate to **Configuration > Mobile Devices** and select the checkbox **use for walk test** for the device to be tested.

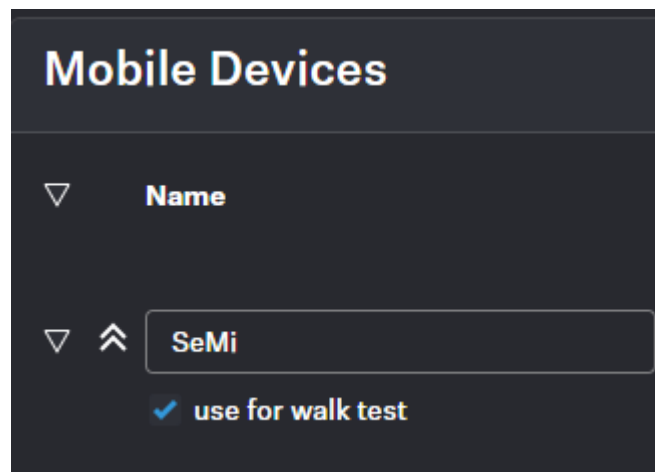



- ▶ Navigate to **Configuration** > **Base Station**, select the measuring interval for the walk test and click on **Start**.
  - ✓ The walk test has been started.
- ▶ Walk the operating environment with the mobile device.
- ▶ Click on **Stop** as soon as the walk test has been performed.
  - ✓ The results of the walk test are automatically downloaded locally to your computer as a `.json` file.

✓ The walk test has been performed successfully.



## Audio interfaces

Here you can monitor all available interfaces and manage the outputs.

A built-in sample rate converter can be used to convert the outputs to predetermined frequencies and generate a custom sample rate for any audio channel. The following settings are available for MADI 1, MADI 2 and Word Clock interfaces:

- Leader 48 kHz
- Leader 96 kHz
- Follow MADI 1 Input
- Follow MADI 2 Input
- Follow World Clock Input
- Follow Audio Network

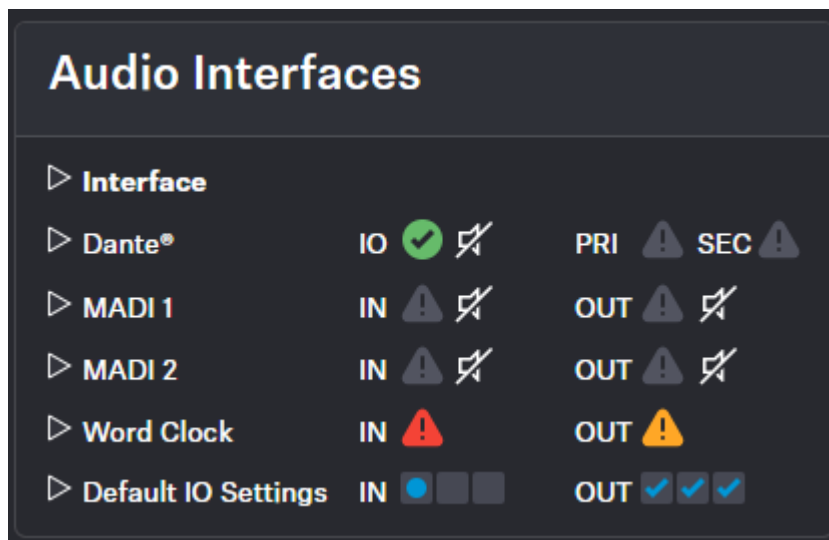

The interface status is indicated by the following colors:

- : OK
- : Not used
- : Attention, e.g.: "fallback active"
- : Warning, e.g.: "input not toggling"

## Audio Network

- Dante®
- Dante® Primary
- Dante® Secondary



### MADI 1

- Input
- Output

### MADI 2

- Input
- Output

### Word Clock BNC

- Input
- Output

### Default Input Interface

- Dante®
- MADI 1
- MADI 2

## Selecting the default audio input/output source

You can select the default source for the audio input and output of your audio interface.

To select the default input interface:

- ▶ In the top bar, navigate to **Configuration RF > Audio Interfaces**.
- ▶ Select the input interface under **Default IO Settings**.
  - ✓ The default input interface has been selected.

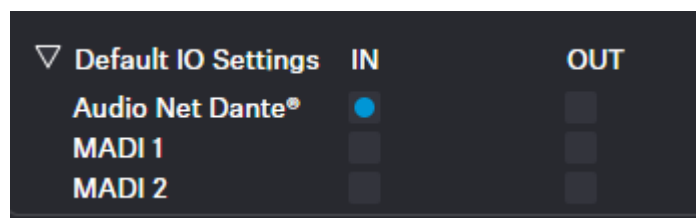

To select the clock source output:

- ▶ Select the desired setting for the clock source under:
  - MADI 1
  - MADI 2
  - Word Clock BNC
- ✓ The clock source output has been selected.



✓ The audio interfaces have been selected.





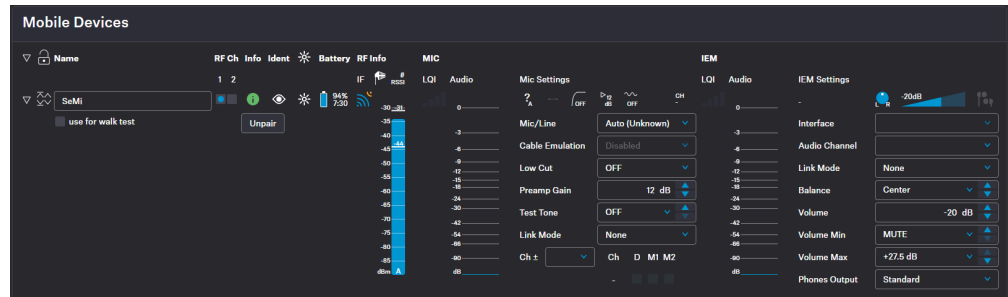

## Mobile Devices

Here you can configure specific settings for mobile devices.





The following interactions can be made for each mobile device:

### General









-  Locking the sorting of mobile devices
- Changing the name of the device (see [Changing the device name](#))
- Assigning an RF channel (see [Assigning an RF channel](#))
-  Monitoring the status of the device (connection status, temperature, entitlement, data-transition etc)
-  Changing the LED brightness (see [Setting the LED brightness](#))
-  Identifying the device (see [Identifying your mobile device](#))
- Pairing/unpairing the device (see [Pairing/unpairing mobile devices](#))
-  Monitoring the battery status

**i** The time specifications for hh:mm have a tolerance of  $\pm 10$  minutes. If the battery shows  $< 10\%$ , a lower battery level is displayed than is actually still available.  
The displayed time is an estimated remaining runtime based on current power consumption. Different audio link modes, headphone types and IEM volume can change this estimate.









-  Interference level at mobile device
-  Receive Single Strength Indication at the dominant antenna
-  Link Quality Input (LQI)



## MIC

-  Link Quality Input (LQI) (see [Selecting audio link mode \(Mic/Line\)](#))
-  Input Mic/Line (see [Selecting the Mic/Line input](#))
-  Cable Emulation (see [Activating/deactivating cable emulation](#))
-  Low Cut (see [Activating/deactivating Low Cut](#))
-  Preamp Gain (see [Setting the Preamp Gain](#))
-  Test Tone (see [Activating/deactivating Test Tone](#))
-  Link Mode (color depends on the mode) (see [Selecting audio link mode \(Mic/Line\)](#))
-  Assigned channel (see [Assigning an RF channel](#))

## In-Ear Monitoring (IEM)

- Interface (see [Selecting the default audio input/output source](#))
- Channel (see [Selecting an audio channel \(IEM link\)](#))
- Mode (see [Selecting audio link mode \(IEM\)](#))
  -  Max Range
  -  Max Link Density
  -  Live Link Density Range
  -  Live Link Density Range
  -  Live Low Latency
  -  Live Ultra Low Latency
-  Balance / Center (see [Adjusting the balance](#))
-  Volume (see [Setting the volume](#))
-  Headphone
- Phones Output (see [Selecting the phones output](#))

## Pairing/unpairing mobile devices

In the WebUI, you can pair up to 128 mobile devices to a Base Station within one RF channel.

Mobile devices can only be paired and operated with one Base Station at a time. If a mobile device is to be used with another Base Station, it must first be paired again.





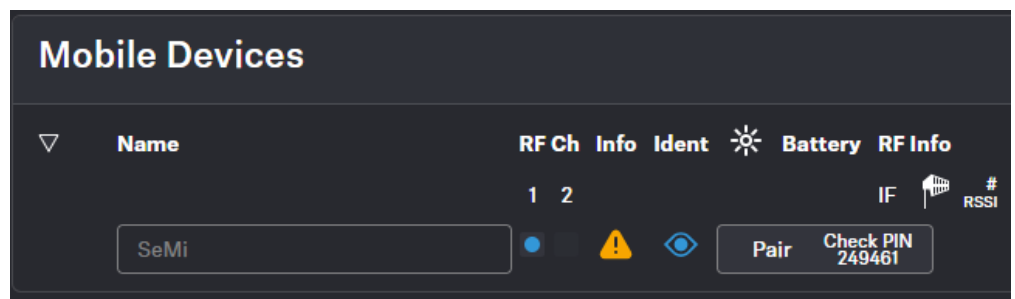

**i** Please unmute at least one RF channel before pairing if this was not done automatically.

**To pair a mobile device:**

- ▶ In the top bar, navigate to **Configuration > Base Station**.
- ▶ Click on **Enable Pairing**.
  - ✓ The Base Station starts the pairing process for 300 seconds.
- ▶ Switch on your mobile device and activate **Pairing Mode** if it has not been activated automatically ([Switching the SEK on and off](#)).
  - ✓ After a few seconds, the available mobile devices are displayed in the list below under **Mobile Devices**. A verification PIN is displayed on the mobile device and in the WebUI.



- ▶ Verify the PIN on the mobile device and click on **Pair**.
  - ✓ The mobile device has been paired successfully. The device state color changes to:
    -  green (successfully paired)
    -  gray (assigned RF channel not on air)
    -  yellow (firmware mismatch) or
    -  red (unconnected, no RF channel selected, not available)

**To unpair a mobile device:**

**i** To unpair a paired device, the audio links must first be deactivated.

- ▶ In the top bar, navigate to **Configuration > Mobile Devices**.
- ▶ Click on the button **Unpair > Confirm** in the line of the mobile device to be unpaired.
  - ✓ The mobile device has been successfully unpaired.



✓ The mobile devices have been successfully paired/unpaired.



## Identifying your mobile device

You can remotely identify your mobile device.

**To identify the mobile device:**

- ▶ In the top bar, navigate to **Configuration > Mobile Devices**.
- ▶ Click on the  **Identify** icon.
  - ✓ The LED on the mobile device flashes white alternately for 5 seconds.

✓ The mobile device has been identified.



## Assigning an RF channel

You can assign a configured RF channel to your mobile device.

To assign the RF channel:

- ▶ In the top bar, navigate to **Configuration > Mobile Devices**.
- ▶ Select your configured channel under **RF Ch**.

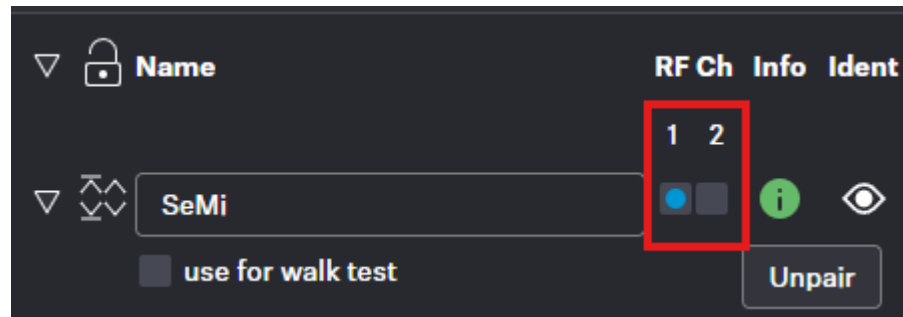

**i** To change the RF channel, you must first deactivate the audio Link Mode and the audio Channels.

- ▶ Enable the toggle switch of the configured RF channel.

✓ The RF channel has been assigned to your mobile device.









## Selecting audio link mode (IEM)

You can select the audio mode for your IEM link.

**i** Please note that the bandwidth utilization varies depending on the link mode.

The following modes are available:





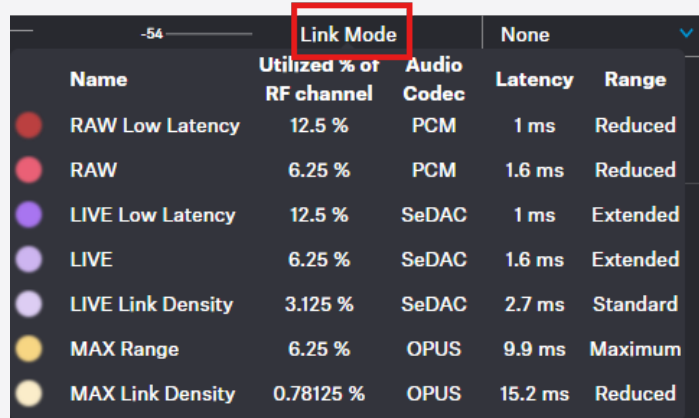

-  Max Range
-  Max Link Density
-  Live Link Density Range
-  Live Link Density Range
-  Live Low Latency
-  Live Ultra Low Latency

To select the audio mode:

- ▶ In the top bar, navigate to **Configuration > Mobile Devices > IEM Settings**.
- ▶ Select the audio mode from the drop-down list **Link Mode**.

**i** Hover your mouse over the word **Link Mode** to display a tabular listing of possible modes.



| Name  | Utilized % of RF channel | Audio Codec | Latency | Range    |
|---|--------------------------|-------------|---------|----------|
|  RAW Low Latency   | 12.5 %                   | PCM         | 1 ms    | Reduced  |
|  RAW               | 6.25 %                   | PCM         | 1.6 ms  | Reduced  |
|  LIVE Low Latency  | 12.5 %                   | SeDAC       | 1 ms    | Extended |
|  LIVE              | 6.25 %                   | SeDAC       | 1.6 ms  | Extended |
|  LIVE Link Density | 3.125 %                  | SeDAC       | 2.7 ms  | Standard |
|  MAX Range         | 6.25 %                   | OPUS        | 9.9 ms  | Maximum  |
|  MAX Link Density  | 0.78125 %                | OPUS        | 15.2 ms | Reduced  |

 The audio mode has been selected.









## Selecting audio link mode (Mic/Line)

You can select the audio mode for your Mic/Line link.

**i** Please note that the bandwidth utilization varies depending on the link mode.

The following modes are available:





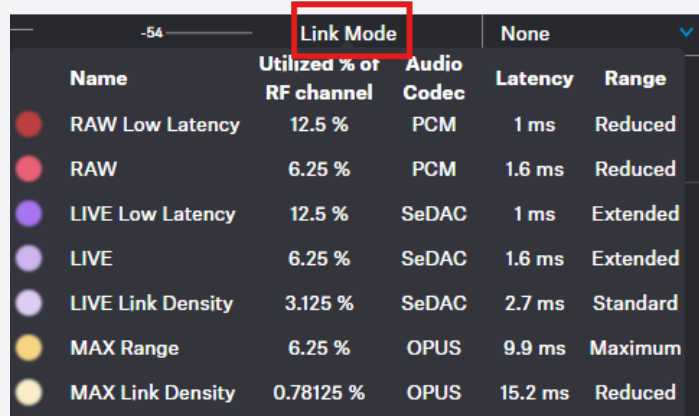

-  Max Range
-  Max Link Density
-  Live Link Density
-  LIVE
-  Live Low Latency
-  RAW
-  RAW Live Low Latency

To select the audio mode:

- ▶ In the top bar, navigate to **Configuration > Mobile Devices > Mic Settings**.
- ▶ Select the audio mode from the drop-down list **Link Mode**.

**i** Hover your mouse over the word **Link Mode** to display a tabular listing of possible modes.



| Name  | Utilized % of RF channel | Audio Codec | Latency | Range    |
|---|--------------------------|-------------|---------|----------|
|  RAW Low Latency   | 12.5 %                   | PCM         | 1 ms    | Reduced  |
|  RAW               | 6.25 %                   | PCM         | 1.6 ms  | Reduced  |
|  LIVE Low Latency  | 12.5 %                   | SeDAC       | 1 ms    | Extended |
|  LIVE              | 6.25 %                   | SeDAC       | 1.6 ms  | Extended |
|  LIVE Link Density | 3.125 %                  | SeDAC       | 2.7 ms  | Standard |
|  MAX Range         | 6.25 %                   | OPUS        | 9.9 ms  | Maximum  |
|  MAX Link Density  | 0.78125 %                | OPUS        | 15.2 ms | Reduced  |

 The audio mode has been selected.



## Selecting the Mic/Line input

You can select the audio input as the signal source for your Mic/Line link.

**i** For a smooth system configuration, we recommend first selecting the link modes and afterwards assigning the channels:

- Selecting audio link mode (Mic/Line)
- Selecting audio link mode (IEM)
- [Adding/removing an audio channel \(Mic/Line\)](#)
- [Selecting an audio channel \(IEM link\)](#)
- [Selecting the IEM audio interface](#)

**i** You can route audio links to several channels. Routing can be performed easily via the routing matrix (see [Audio inputs and outputs](#)).

The following input signals are available:

- Auto (unknown)
- Mic
- Line

**i** The automatic mic/line detection is based on power consumption and is optimized for use with Sennheiser microphones. Because third-party microphones vary widely, reliable detection cannot always be ensured.

### To choose the audio input:

- ▶ In the top bar, navigate to **Configuration > Mobile Devices > Mic Settings**.
- ▶ Select the audio input from the drop-down list **Mic/Line**.

✓ The audio input has been selected.



## Adding/removing an audio channel (Mic/Line)

You can assign an audio channel number and the interface output for your Mic/Line link.

- i** You can route audio links to several channels. Routing can be performed easily via the routing matrix (see [Audio inputs and outputs](#)).

### To add an audio channel:

- ▶ In the top bar, navigate to **Configuration > Mobile Devices > Mic Settings**.
- ▶ Select the channel number from the drop-down list **Channel** which is indicated with a plus in front of it (e.g. **+1**).

### To remove the link channel:

- ▶ Select the channel number from the drop-down list **Channel** which is indicated with a minus in front of it (e.g. **-1**).

### To select the output interface of the assigned link channel:

- ▶ Activate/deactivate the check-boxes under **D** (for DANTE®), **M1** (for MADI 1) and/or **M2** (for MADI 2).

- ✓ The audio channel and the audio interface output has been added/removed.



## Performing a walk test

A walk test allows you to check the reception quality of your radio links within the operating environment.

The automatically generated data is used to provide an overview of the frequency behavior with the simulated devices and their configuration under the intended conditions. The result is represented as plain data in a `.json` file. The implementation of a graphical representation of the result is in planning.

You can specify the measurement interval of the walk test in seconds:

- 1
- 2
- 3
- 4
- 5
- 10
- 20
- 30

**i** If the total data rate is too high, individual values are omitted.

### To perform a walk test:

- ▶ Switch on the transmitter and the receiver of the radio link you want to check.
- ▶ In addition, switch on all other devices that you want to use in the operating environment.
- ▶ Navigate to **Configuration > Mobile Devices** and select the checkbox **use for walk test** for the device to be tested.

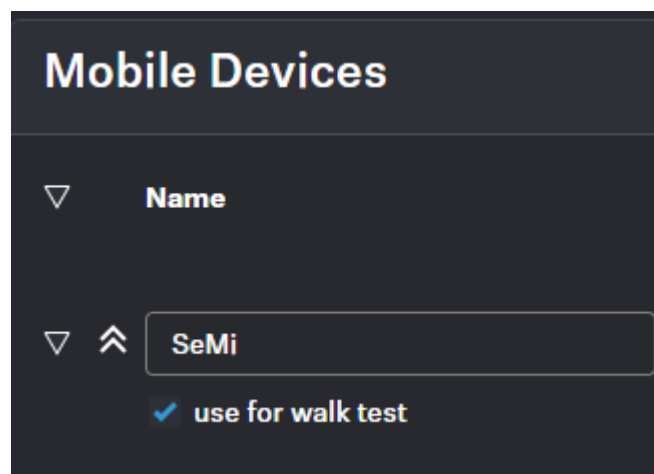



- ▶ Navigate to **Configuration** > **Base Station**, select the measuring interval for the walk test and click on **Start**.
  - ✓ The walk test has been started.
- ▶ Walk the operating environment with the mobile device.
- ▶ Click on **Stop** as soon as the walk test has been performed.
  - ✓ The results of the walk test are automatically downloaded locally to your computer as a `.json` file.

✓ The walk test has been performed successfully.



## Changing the device name

You can change the device name for your mobile device.

**i** For security reasons, please do not enter any sensitive personal data as the device name.

### To change the device name:

- ▶ In the top bar, navigate to **Configuration > Mobile Devices**.
- ▶ Edit the name under **Name** and confirm with **ENTER**.
  - ✓ The name is immediately transmitted to the mobile device and saved.





✓ The device name has been changed.



## Setting the LED brightness

You can adjust the brightness of your LED on the mobile device.

There are four settings for the LED brightness:

-  OFF
-  Dim
-  Standard
-  Bright

### To change the LED brightness:

- ▶ In the top bar, navigate to **Configuration > Mobile Devices**.
- ▶ Click on the  icon multiple times to set the LED to your desired brightness.

✓ The LED brightness has been set.



## Selecting the IEM audio interface

You can select the desired audio interface as the signal source for your IEM link.

The following interfaces are available:

- Dante®
- MADI 1
- MADI 2

### To choose the audio interface:

- ▶ In the top bar, navigate to **Configuration > Mobile Devices > IEM Settings**.
- ▶ Select the audio interface from the drop-down list **Interface**.

✓ The audio interface has been selected.



## Selecting an audio channel (IEM link)

You can assign an audio channel number for your IEM link.

**i** For a smooth system configuration, we recommend first selecting the link modes and afterwards assigning the channels:

- Selecting audio link mode (Mic/Line)
- Selecting audio link mode (IEM)
- [Adding/removing an audio channel \(Mic/Line\)](#)
- [Selecting an audio channel \(IEM link\)](#)
- [Selecting the IEM audio interface](#)

**i** It is also possible to select an existing link (marked with \*), as long as it is using the same RF channel.

### To add an audio channel:

- ▶ In the top bar, navigate to **Configuration > Mobile Devices > IEM Settings**.
- ▶ Select the channel number from the drop-down list **Audio Channel**.

✓ The audio channel has been selected.



## Adjusting the balance

You can change the balance for your IEM link.

The following values can be selected directly and adjusted individually in steps of 1%:

- 100% Left
- 75% Left
- 50% Left
- 25% Left
- Center
- 25% Right
- 50% Right
- 75% Right
- 100% Right

### To change the balance:

- ▶ In the top bar, navigate to **Configuration > Mobile Devices > IEM Settings**.
- ▶ Select the balance mode from the drop-down list **Balance**.

✓ The balance mode has been changed.



## Setting the volume

The volume can be controlled directly from the device as well as from the WebUI.

If the volume value is changed on the device, this change is displayed in the WebUI in real time.

### WARNING



#### Hearing damage due to high volumes

This product is capable of producing sound pressure levels exceeding 85 dB (A). Volume levels that are too high may damage your hearing.

- ▶ Reduce the volume and the microphone amplification, if applicable, before using the product.

#### To set the volume:

- ▶ In the top bar, navigate to **Configuration > Mobile Devices > IEM Settings**.
- ▶ Enter the desired volume level in dB under **Volume**.

✓ The volume has been set.



## Setting the min volume

You can set a predefined min volume for your IEM link.

The volume set here is the minimum level that is sent to your dedicated mobile device.

The following values can be selected directly and adjusted individually in steps of 0.5 dB:

- -6 dB
- -12 dB
- -18 dB
- -24 dB
- -30 dB
- -36 dB
- -42 dB
- -48 dB
- -54 dB
- -60 dB
- MUTE

### WARNING



#### Hearing damage due to high volumes

This product is capable of producing sound pressure levels exceeding 85 dB (A). Volume levels that are too high may damage your hearing.

- ▶ Reduce the volume and the microphone amplification, if applicable, before using the product.

#### To set the min volume:

- ▶ In the top bar, navigate to **Configuration > Mobile Devices > IEM Settings**.
- ▶ Select the min volume level in dB under **Volume min**.



The min volume has been set.



## Setting the max volume

You can set a predefined max volume for your IEM link.

The volume set here is the maximum level that is transmitted to your connected mobile device.

The following values can be selected directly and adjusted individually in steps of 0.5 dB:

- -27.5 dB
- -24 dB
- -18 dB
- -12 dB
- -6 dB
- 0 dB
- +6 dB
- +12 dB
- +18 dB
- +24 dB
- +27.5 dB

### WARNING



#### Hearing damage due to high volumes

This product is capable of producing sound pressure levels exceeding 85 dB (A). Volume levels that are too high may damage your hearing.

- ▶ Reduce the volume and the microphone amplification, if applicable, before using the product.

#### To set the max volume:

- ▶ In the top bar, navigate to **Configuration > Mobile Devices > IEM Settings**.
- ▶ Select the max volume level in dB under **Volume max**.



The max volume has been set.



## Selecting the phones output

Selecting the output for the PHONES socket of the mobile device.

The following outputs are available:

- Standard: Unbalanced mono or stereo phones output.
- Balanced: Enables right channel inversion for mono link modes.

The 'Balance' setting is disabled in this mode.

With this setting, for example, a cable with the following pinout can be used to connect the phones output to a balanced line input.

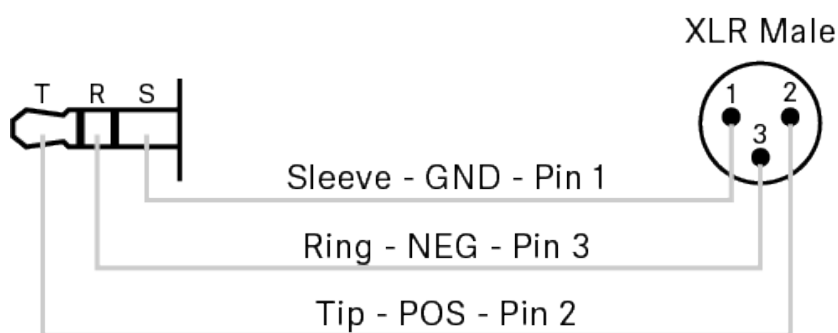

**To choose the phone output:**

- ▶ In the top bar, navigate to **Configuration > Mobile Devices > IEM Settings**.
- ▶ Select the phone output from the drop-down list **Phones Output**.

✓ The phones output has been selected.



## Activating/deactivating cable emulation

You can emulate the capacitance of connected cables and influence the sound of your mic/line input.

**i** Cable emulation is only applicable for the line input.

The following presets are available:

- OFF
- Short
- Mid
- Long

### To activate cable emulation:

- ▶ In the top bar, navigate to **Configuration > Mobile Devices > Mic Settings**.
- ▶ Select the value from the drop-down list **Cable Emulation**.

### To deactivate cable emulation:

- ▶ Select the value **OFF**.

**✓** The cable emulation value has been activated/deactivated.



## Activating/deactivating Low Cut

You can reduce or remove low frequencies in the audio signal while allowing high frequencies to pass through.

This allows low-frequency ambient noise to be filtered out of the audio signal, thereby improving the clarity of the audio.

The following presets are available:

- OFF
- 30 Hz
- 60 Hz
- 80 Hz
- 100 Hz
- 120 Hz

### To activate Low Cut:

- ▶ In the top bar, navigate to **Configuration > Mobile Devices > Mic Settings**.
- ▶ Select the value from the drop-down list **Low Cut**.

### To deactivate Low Cut:

- ▶ Select the value **OFF**.

✓ Low Cut has been activated/deactivated.



## Setting the Preamp Gain

With the preamp you can increase the audio level for your Mic/Line output.

To set the gain:

- ▶ In the top bar, navigate to **Configuration > Mobile Devices > Mic Settings**.
- ▶ Enter the desired preamp gain level in 1 dB increments under **Preamp Gain**.

✓ The Preamp Gain has been set.



## Activating/deactivating Test Tone

With a constant test tone, you can simulate and test the performance of your audio devices in different dB levels.

The following values can be selected directly and adjusted individually in steps of 1 dB:

- OFF
- -60 dB
- -54 dB
- -48 dB
- -42 dB
- -36 dB
- -30 dB
- -24 dB
- -18 dB
- -12 dB
- -6 dB
- 0 dB

### To activate the Test Tone:

- ▶ In the top bar, navigate to **Configuration > Mobile Devices > Mic Settings**.
- ▶ Select the value from the drop-down list under **Test Tone**.

### To deactivate the Test Tone:

- ▶ Select the value **OFF**.

✓ The Test Tone has been activated/deactivated.



## Frequency Scan

You can use an RF scan to examine the current frequency situation of your connected antenna.



**i** Make sure that no antenna is activated!

You can monitor and control the following settings in the Frequency Scan menu:

- Selecting the antenna (A-D) connected to the Base Station
- Setting the RefLevel (reference level for frequency scan)
- Setting the Sweep time for frequency scan between 2s (fast update rate) and 60s (slow update rate)
- Setting the resolution bandwidth
- Resetting the peak trace
- Saving all settings to a `.csv` file

## Scanning the RF frequency

You can run a frequency scan to check the current frequency situation in your surrounding area.

The frequency scan provides an overview of the frequency situation in your location. You can save the antenna configuration as a `.csv` info file. This file can be used as a backup file to recapitulate your settings or as local frequency information for your specific environment. You can scan the frequencies of all antennas connected to the Base Station.



The scan can be initiated:

- via the [RF configuration](#) tab to see a small extract without any details or
- via the [Frequency Scan](#) tab for a detailed overview of the frequency situation.

The scan results will be displayed in two different curves:

- **Peak** (red) = Maximum value
- **RMS** (blue) = Average power or strength

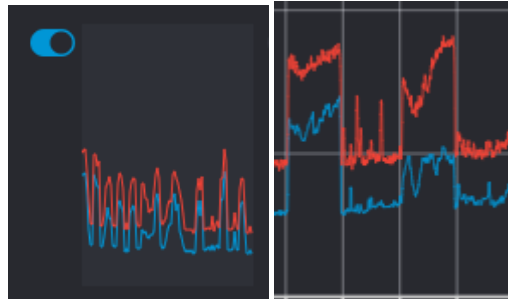

**i** Please note that the antenna must not be assigned to an RF channel before scanning (see [Assigning an antenna to an RF channel](#)).

**To scan the RF frequency via the RF configuration tab:**

- ▶ In the top bar, navigate to **Configuration > RF Configuration**.
- ✓ Under the **RF Scan** drop-down menu, there are four toggle switches that enable and disable the scan function for each connected antenna.



- ▶ Click on the toggle switch of the antenna to be scanned in order to start an immediate scan.
- ✓ The square is highlighted with a blue dot and the scan result is displayed in a small frequency curve after approx. 5 seconds.

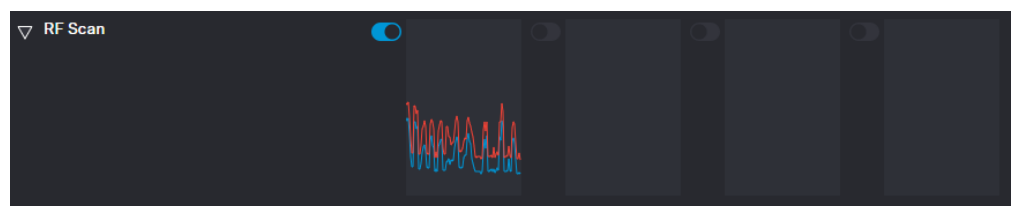



- ▶ In order to view the results,
  - click on the small frequency icon or
  - navigate to **Frequency Scan** in the top bar.

**To scan the RF frequency via the Frequency Scan tab:**

- ▶ In the top bar, navigate to the tab **Frequency Scan**.

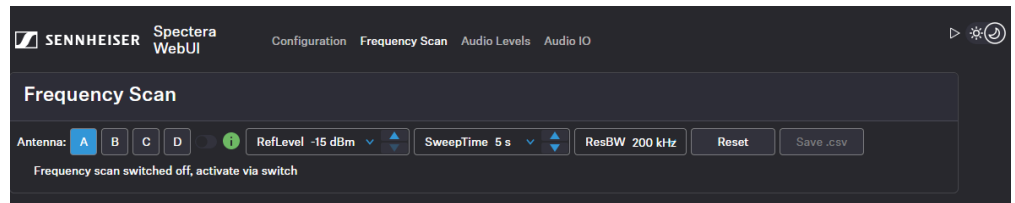

- ▶ Select your antenna to be scanned and adjust your desired settings.
- ▶ Switch on the toggle to start the scan.
  - ✔ The frequency scan is started and the result is displayed in a detailed frequency diagram. Supported frequency ranges are shown in green and unsupported ranges in gray.



**To reset a scan:**

- ▶ Click on **Reset**.
  - ✔ The current scan will be reset.



To save the scan results as `.csv` :

▶ Click on **Save.csv**.

✓ The antenna configuration has been downloaded locally to your computer as a `.csv` file.

✓ The frequency of your connected antenna has been scanned.



## Audio Levels

Under Audio Levels you can monitor all interfaces at a glance.

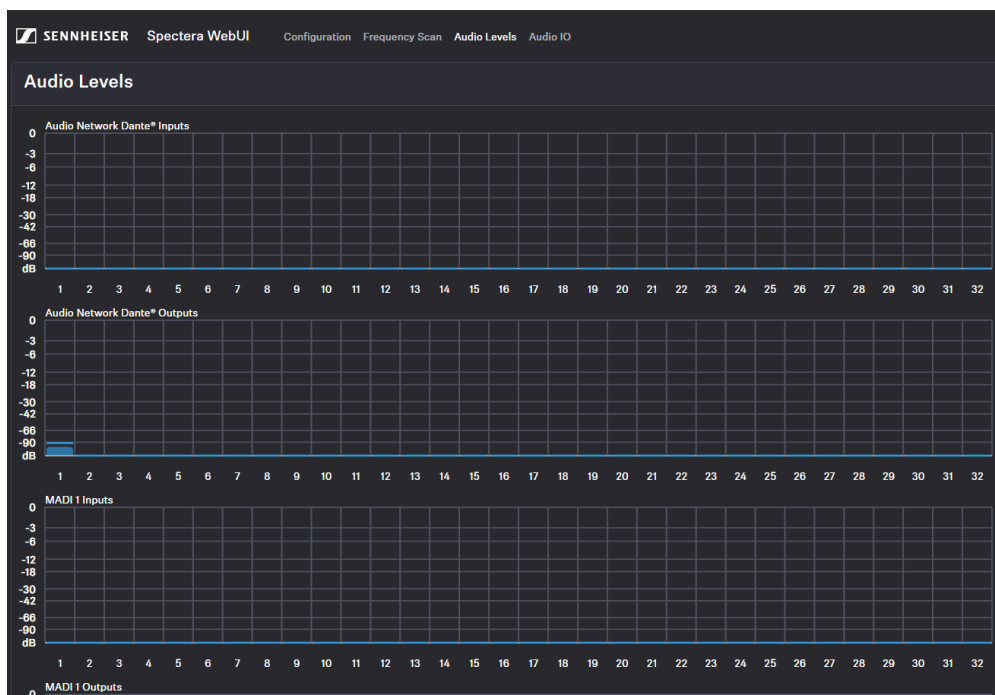

All interfaces are sorted according to their inputs and outputs and displayed visually with a frequency response:

- Dante® Inputs
- Dante® Outputs
- MADI 1 Inputs
- MADI 1 Outputs
- MADI 2 Inputs
- MADI 2 Outputs



## Audio inputs and outputs

Here you have an overview of all channels at a glance and can assign the audio network input and output for the link channels directly and easily.

The link modes assigned in the mobile devices are displayed here. You can select the desired channels directly and assign them to your audio network input or output.

The screenshot shows the 'Audio Inputs and Outputs' configuration page in the Sennheiser Spectera WebUI. The page is divided into two main sections: 'Base Station Audio Inputs (IEM)' and 'Base Station Audio Outputs (MIC)'. Both sections are configured for a mobile device named 'SeMi'.

**Base Station Audio Inputs (IEM)**

| Audio Channel        | 1 | 2 | 3 | 4 | 5 | 6 | 7 | 8 | 9 | 10 | 11 | 12 | 13 | 14 | 15 | 16 | 17 | 18 | 19 | 20 | 21 | 22 | 23 | 24 | 25 | 26 | 27 | 28 | 29 | 30 | 31 | 32 |   |
|----------------------|---|---|---|---|---|---|---|---|---|----|----|----|----|----|----|----|----|----|----|----|----|----|----|----|----|----|----|----|----|----|----|----|---|
| Audio Network Dante® | ● | ● | ● | ● | ● | ● | ● | ● | ● | ●  | ●  | ●  | ●  | ●  | ●  | ●  | ●  | ●  | ●  | ●  | ●  | ●  | ●  | ●  | ●  | ●  | ●  | ●  | ●  | ●  | ●  | ●  | ● |
| MADI 1               | ■ | ■ | ■ | ■ | ■ | ■ | ■ | ■ | ■ | ■  | ■  | ■  | ■  | ■  | ■  | ■  | ■  | ■  | ■  | ■  | ■  | ■  | ■  | ■  | ■  | ■  | ■  | ■  | ■  | ■  | ■  | ■  | ■ |
| MADI 2               | ■ | ■ | ■ | ■ | ■ | ■ | ■ | ■ | ■ | ■  | ■  | ■  | ■  | ■  | ■  | ■  | ■  | ■  | ■  | ■  | ■  | ■  | ■  | ■  | ■  | ■  | ■  | ■  | ■  | ■  | ■  | ■  | ■ |

**Mobile Device Name**: SeMi

**Audio Link Mode**: LIVE

**Base Station Audio Outputs (MIC)**

| Audio Channel        | 1 | 2 | 3 | 4 | 5 | 6 | 7 | 8 | 9 | 10 | 11 | 12 | 13 | 14 | 15 | 16 | 17 | 18 | 19 | 20 | 21 | 22 | 23 | 24 | 25 | 26 | 27 | 28 | 29 | 30 | 31 | 32 |
|----------------------|---|---|---|---|---|---|---|---|---|----|----|----|----|----|----|----|----|----|----|----|----|----|----|----|----|----|----|----|----|----|----|----|
| Audio Network Dante® | ✓ | ✓ | ✓ | ✓ | ✓ | ✓ | ✓ | ✓ | ✓ | ✓  | ✓  | ✓  | ✓  | ✓  | ✓  | ✓  | ✓  | ✓  | ✓  | ✓  | ✓  | ✓  | ✓  | ✓  | ✓  | ✓  | ✓  | ✓  | ✓  | ✓  | ✓  | ✓  |
| MADI 1               | ✓ | ✓ | ✓ | ✓ | ✓ | ✓ | ✓ | ✓ | ✓ | ✓  | ✓  | ✓  | ✓  | ✓  | ✓  | ✓  | ✓  | ✓  | ✓  | ✓  | ✓  | ✓  | ✓  | ✓  | ✓  | ✓  | ✓  | ✓  | ✓  | ✓  | ✓  | ✓  |
| MADI 2               | ✓ | ✓ | ✓ | ✓ | ✓ | ✓ | ✓ | ✓ | ✓ | ✓  | ✓  | ✓  | ✓  | ✓  | ✓  | ✓  | ✓  | ✓  | ✓  | ✓  | ✓  | ✓  | ✓  | ✓  | ✓  | ✓  | ✓  | ✓  | ✓  | ✓  | ✓  | ✓  |



## Changing the device password

You have two options to change the device password on your Base Station.

You have two options:

- Change the password before logging in.
- Change or reset the password by resetting the device to factory settings.

**i** To change or reset the device password, the device must be reset to factory settings.

### NOTICE



#### Data loss during the factory reset

All audio devices will be unpaired and all audio routes will be deleted.

All settings (including the device password) are reset to the default values. The license remains activated.

After the reset, the device is restarted automatically.

- ▶ Do not reset the Base Station during an active live audio transmission.

To reset the password to factory settings, you have two options available:

- Reset via the device (see [Reset](#))
- Reset via the WebUI interface (see [Resetting the Base Station](#))

#### To change the password:

- ▶ Enter the following URL into your browser: `https://deviceIP/specterawebui/index.html`

**i** Since the certificate is unknown to your browser, a security warning is displayed the first time you run the application. The security warning depends on the browser you are using.

- ▶ Click on **Change**.



## ControlSennheiser Login

### Welcome to Spectera Base Station

Password

If you have forgotten the password, please perform a factory reset directly on the Base Station. Then refresh the WebUI page and set a new password. Please note that all configuration data will be lost.

⚠ The audio network is unencrypted by default. Configuring Dante® media encryption requires Dante® Director or Dante® Domain Manager.

📄 We collect operational data to continually improve the stability and functionality of Spectera. We pseudonymize the data so that there is no direct personal reference. You can prevent tracking in the settings.

- ▶ Enter the old password.
- ▶ Enter the new password two times.

## ControlSennheiser Change Password

Old Password

New Password

Re-enter New Password

Password 10-64 characters, at least one capital letter, one lower letter, one numeral and one special character

If you have forgotten the old password, please perform a factory reset directly on the Base Station. Then refresh the WebUI page and set a new password. Please note that all configuration data will be lost.

- ▶ Click on **Change** to save the new password or click on **Abort** to cancel the change.



- ✓ The password has been changed or the Base Station has been reset to its factory default settings.



## 5. Knowledge base

Central hub for information, resources, and guides with further content on the product and/or service.

### Network guide

This network guide is intended for IT administrators, system integrators and event technicians and serves as an planning and configuration guide for integrating components of the Spectera offering into diverse network environments from small home networks up to enterprise networks.

The guide contains recommendations on network setup for transmission of control data and audio content (via Dante®).

#### Introduction

This network guide is intended for IT administrators, system integrators and event technicians and serves as an planning and configuration guide for integrating components of the Spectera offering into diverse network environments from small home networks up to enterprise networks.

The guide contains recommendations on network setup for transmission of control data and audio content (via Dante®).



## General requirements

### Operating systems

The Spectera Base Station as network device is able to be controlled by network-capable PC or Mac devices.

The following system requirements apply for operation with Spectera WebUI and Sennheiser LinkDesk:

### System requirements

- Intel i5 Dual Core processor/M1 Mac/or similar
- 16 GB RAM
- At least 4 GB hard disk space (5 GB for Mac devices)
- Gigabit LAN interface
- Windows® 10, 11, Server 2019, Server 2022 (x64) or higher
- Mac OS Big Sonoma or later
- IPv4 network

### Supported web browsers for Spectera WebUI

- Google Chrome: 125 or later
- Microsoft Edge: 125 or later
- Mozilla Firefox: 128 or later
- Apple Safari: 17 or later
- JavaScript must be activated



## Network

### Bandwidth and speed

When it comes to bandwidth requirements for high-quality audio, there are a number of factors that can affect the input and output of the audio. The network speed required for especially audio transmission via Dante® should be as high as possible to ensure a smooth listening experience. As a rule, the minimum bandwidth for transmitting and receiving audio at the Spectera Base Station is approximately the following:

The majority of audio used in professional settings is PCM (uncompressed), sampled at 48 kHz and a bit depth (word length) of 24 bits. Dante® audio is unicast by default but can be set to use multicast for cases of one-to-many distribution.

- Dante® packages audio into flows to save on network overhead.
- Unicast Audio flows contain up to 4 channels. The samples-per-channel can vary between 4 and 64, depending on the latency setting of the device. Bandwidth usage is about 6 Mbps per typical unicast audio flow.
- Bandwidth for multicast flows is dependent on the number of audio channels used. Bandwidth is about 1.5 Mbps per channel.

Source: [Audinate Dante Information for Network Administrators \(PDF\)](#)

### Internet access

For both components Spectera Base Station and Sennheiser LinkDesk we recommend to provide permanent Internet access. Please refer to chapter [Ports, protocols and services](#) to get more details about used Internet services.

**i** At least for the initial product activation of the Spectera Base Station and for the use of the optional Sennheiser Account Login in Sennheiser LinkDesk it is mandatory to have a direct Internet access and DNS support.

**i** At the moment it is not possible to manually configure any network proxy and DNS server at Spectera Base Station. Please make sure to provide direct Internet access e.g. via white-listing the device and any used port, protocol and domain and using DHCP to provide DNS server settings.



### Network infrastructure (switches/cables)

Generally any kind of unmanaged or managed network switch can be used for control and audio data transmission. For proper operation of Dante® some fundamental requirements need to be fulfilled:

- When using managed switches, ensure that they allow EEE (Energy Efficient Ethernet or "Green Ethernet") to be disabled. Make sure that EEE is disabled on all ports used for real-time Dante traffic.
- When using unmanaged switches, do not use switches that support the EEE function, because it cannot be disabled.
- Make sure that the switch supports Quality of Service (QoS) and that it is enabled.
- For larger networks, consider using VLANs to segment audio traffic from other types of network traffic.

**i** For further information about that topic, please refer to the: [Audinate FAQ - Networks and Switches](#). Additionally, there is a list of incompatible switches available at Audinate: [Audinate List of incompatible EEE switches \(PDF\)](#)

To ensure a reliable transmission speed of audio and control data with the Spectera Base Station, please use an RJ45 network cable with the CAT5e S/FTP standard or higher.



## Network setups

To operate the several components of the Spectera offering they need to be integrated into a network setup, either existing or new. Following figure shows a general overview of the network setup and their participants.

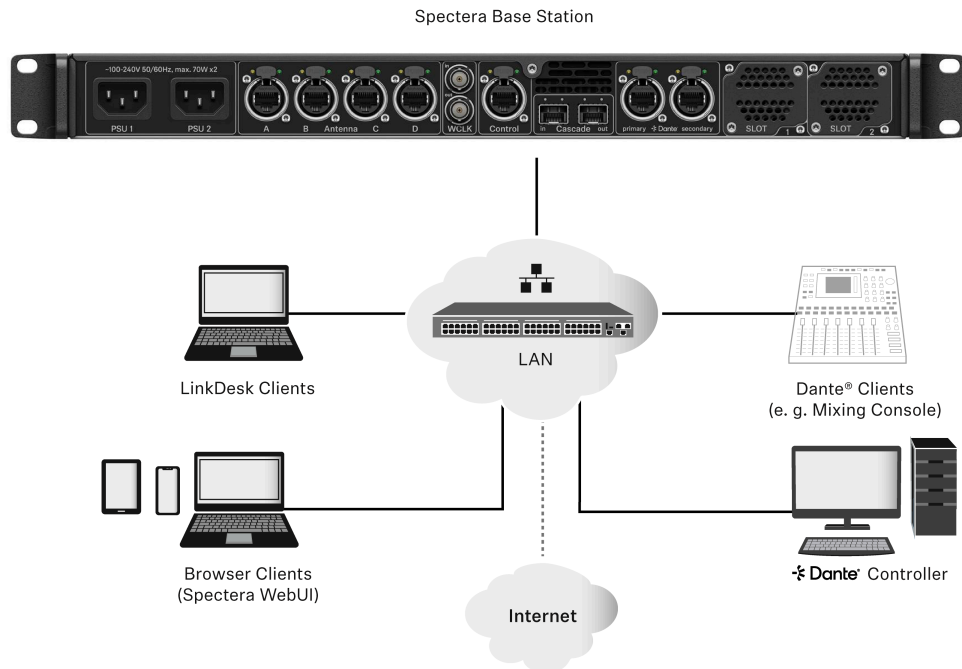

### Spectera Base Station

This Sennheiser device has 3 network interfaces. One interface dedicated for control data and two interfaces for audio data (specifically Dante®). There is a primary and a secondary interface for redundancy of the audio transmission.

### Sennheiser LinkDesk client

This client can be any host computer (PC or Mac), with the LinkDesk software application installed.

### Browser Client (Spectera WebUI)

This client can be any host computer (PC, Mac, Tablet, Smartphone), with a supported web browser installed, accessing the Spectera WebUI.

### Dante® client

This can be any device with a Dante® network interface installed. This ranges from Virtual Dante® Soundcards installed on a host computer up to dedicated devices like a Mixing Console.



## Dante® Controller

This is typically host computer (PC or Mac), with the Dante® Controller software application installed. This application configures and controls all the Dante® devices and audio streams inside the network.

## LAN with network switches and router

This can be any network switch for routing the network communication inside the Local Area Network (LAN) and any network router providing the gateway to other networks and to the Internet.

## Spectera Base Station - network configuration

Depending on the desired network address configuration all network interface (Control and both Dante®) can be operated in following IP Modes with IPv4 only:

- Fixed/Static IP
- Auto IP (DHCP or Zeroconf)

Additionally it can be configured if mDNS/DNS-SD information shall be published by the device or not.

### **i** Dante® restrictions

- It is not possible to deactivate the Dante® functionality for the both Dante® ports.
- Dante® ports are shutdown when the device is in standby mode.
- Network configuration of Dante® ports can only be done via Dante® Controller software application.
- By default the Dante® ports are configured to Auto IP. If Fixed/Static IPs have been configured and the device cannot be reached anymore, the IP Mode can only be reset to Auto IP by a Factory Reset of the device.
- The Dante primary and secondary networks must not be directly connected to each other (network loop). Make sure you always connect the Base Station Dante network ports to two different networks that do not run via a common switch.

## Shared Network Mode

In Shared Network Mode both networks for Control and Dante® are using the same physical network infrastructure.

- Configure both Control and Dante® networks over one switch / router.
- Use two different IPs to address the Control network and the Dante® network separately.



**i** The Spectera Base Station can not be configured to use VLAN tagging (IEEE 802.1Q) at its network ports. Still it is possible to use network switches that support VLANs to separate the Control and Dante® traffic within the same physical network. Please make sure that the switch is configured to forward untagged traffic from both networks to the respective ports of the Base Station. Additionally, make sure that the switch is configured to forward multicast traffic for the Dante® network.

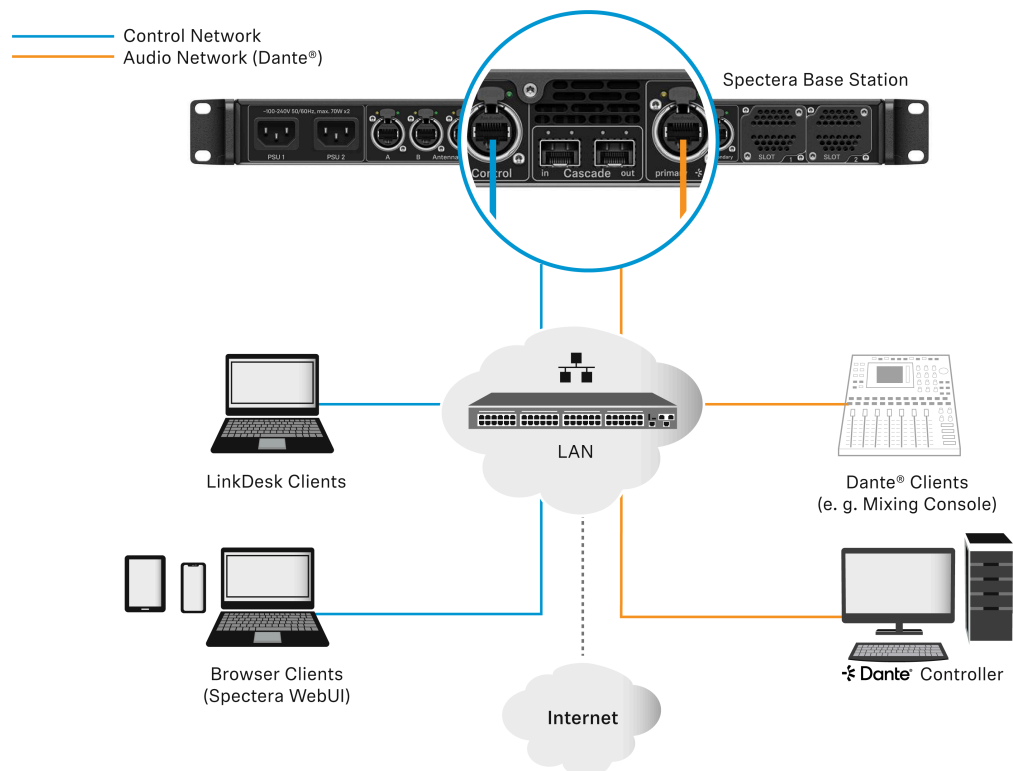

### Split Network Mode

In Split Network Mode both networks for Control and Dante® are using different physical network infrastructure.

- Configure both Control and Dante® networks over two different switches / routers.
- Use two different IPs to address the Control network and the Dante® network separately.

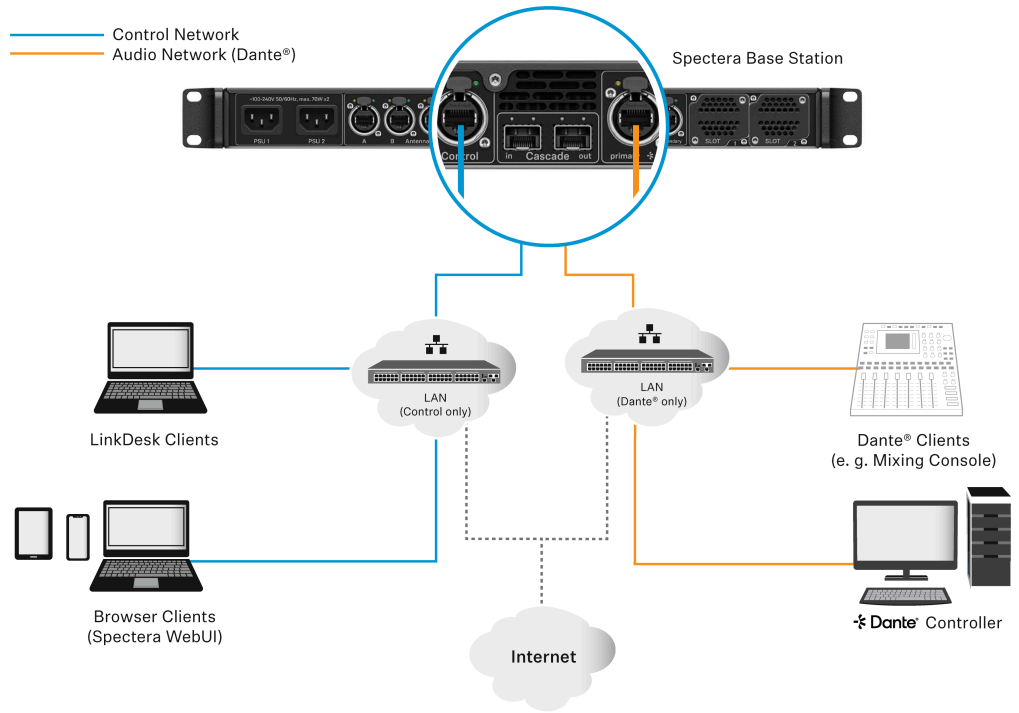



## Ports, protocols and services

### Spectera Base Station

In order to use the Spectera Base Station device in a network, certain ports must be enabled (especially for the organization/enterprise firewall) for communication between software and devices.

**i** If necessary, please contact the local administrator to configure the required ports.

#### Ports - Base Station Control Network Interface

| Address   | Port | Protocol    | Type      | Service                           | Usage  |
|---|------|-------------|-----------|-----------------------------------|--|
| <b>Requests from device to ...</b>  |      |             |           |                                   |  |
| Sennheiser License Server address <sup>1</sup>                                  | 80   | HTTPS (TCP) | Unicast   | Sennheiser License Server         | Activation of devices                            |
| ANY address of time server (see list of <a href="#">NTP time server pools</a> ) | 123  | NTP         | Unicast   | NTP Time Server                   | Synchronize system time                          |
| 224.0.0.251   | 5353 | mDNS (UDP)  | Multicast | mDNS, DNS-SD                      | (optional - if desired) Device/Service Discovery |
| <b>Requests to device from ...</b>  |      |             |           |                                   |  |
| ANY IP of SSCv2 client  | 443  | HTTPS (TCP) | Unicast   | SSCv2 - Spectera Base Station API | Monitor+Control communication from clients       |
| <sup>1</sup> my.nalpeiron.com   |      |             |           |                                   |  |

#### NTP servers

To correctly operate with licenses and certificates, the Spectera Base Station needs a correct system time. The device will use the well-established NTP mechanism from the IP protocol stack to synchronize clock between a time server in a network and the client inside the device.

Currently for an IT administrator or system integrator it is not possible to manually configure a dedicated NTP server to be used by the Spectera Base Station. Being able to configure a dedicated NTP server manually is a planned feature for an upcoming release.



The device behaves the following way:

- If a time server configuration has been provided via DHCP or manually, it tries to connect and sync to that time server first.
- Otherwise the device is trying to access any server of following list of time server pools worldwide publicly available.

**i** An IT administrator has to assure to provide Internet access to at least one of the server pools and to provide DNS settings via DHCP to the device.

List of NTP time server pools:

- pool.ntp.org
- time.nist.gov
- time.aws.com
- time.cloudflare.com

### Ports - Base Station Dante® Network Interfaces

Spectera Base Station requires several ports to be opened for both Dante® Network Interfaces to operate properly. For the list of ports and more detailed information, please refer directly to the Dante® website: [Audinate FAQ - Networks and Switches](#).



## Spectera WebUI

In order to use the Spectera WebUI, certain ports must be enabled (especially for the organization/enterprise firewall) for communication between software and devices.

**i** If necessary, please contact the local administrator to configure the required ports.

### Port requirements

| Address  | Port | Protocol    | Type    | Service                           | Usage                                    |
|--|------|-------------|---------|-----------------------------------|--|
| <b>Requests from host to ...</b>                                     |      |             |         |                                   |  |
| ANY IP of a Base Station   | 443  | HTTPS (TCP) | Unicast | SSCv2 - Spectera Base Station API | Monitor+Control communication to devices |
| Sennheiser User Insights addresses <sup>1</sup>                      | 443  | HTTPS (TCP) | Unicast | Sennheiser User Insights          | Analytics of usage and operational data  |
| <sup>1</sup> sennheiseruserinsights.matomo.cloud<br>cdn.matomo.cloud |      |             |         |                                   |  |



## Sennheiser LinkDesk

In order to use the Sennheiser LinkDesk software, certain ports must be enabled (especially for the organization/enterprise firewall) for communication between software and devices.

**i** If necessary, please contact the local administrator to configure the required ports.

### Port requirements

| Address   | Port  | Protocol    | Type      | Service                           | Usage  |
|---|-------|-------------|-----------|-----------------------------------|--|
| <b>Host Internal</b>                            |       |             |           |                                   |  |
| LOCALHOST                                       | 54352 | HTTPS (TCP) | Unicast   | LinkDesk backend                  | Internal backend communication                   |
| <b>Requests from host to ...</b>                |       |             |           |                                   |  |
| ANY IP of a Base Station                        | 443   | HTTPS (TCP) | Unicast   | SSCv2 - Spectera Base Station API | Monitor+Control communication to devices         |
| Sennheiser CIAM addresses <sup>1</sup>          | 443   | HTTPS (TCP) | Unicast   | Sennheiser CIAM                   | Sennheiser account Sign-in/Log-in                |
| Sennheiser User Insights addresses <sup>2</sup> | 443   | HTTPS (TCP) | Unicast   | Sennheiser User Insights          | Analytics of usage and operational data          |
| <b>Requests to host from ...</b>                |       |             |           |                                   |  |
| 224.0.0.251                                     | 5353  | mDNS (UDP)  | Multicast | mDNS, DNS-SD                      | (optional - if desired) Device/service discovery |

<sup>1</sup> accounts-pro-emea.sennheiser-cloud.com

b2c-config.sennheisercloud.com

<sup>2</sup> sennheiseruserinsights.matomo.cloud

cdn.matomo.cloud



## Best practice

### Sharing Internet connection in small network setups

It is possible to operate the Spectera offering without dedicated router networks e.g. in really small setups, but we do recommend to always use some kind of home network router for trouble-free usage.

Especially for providing Internet access to Spectera Base Station it is possible to use the builtin functionality of Windows and MacOS for Internet Connection Sharing.

**i** For enterprise networks we DO NOT RECOMMEND the usage of Internet Connection Sharing. Most of the times it is even prohibited by enterprise IT policy to use such service.

The network setup might look like this:

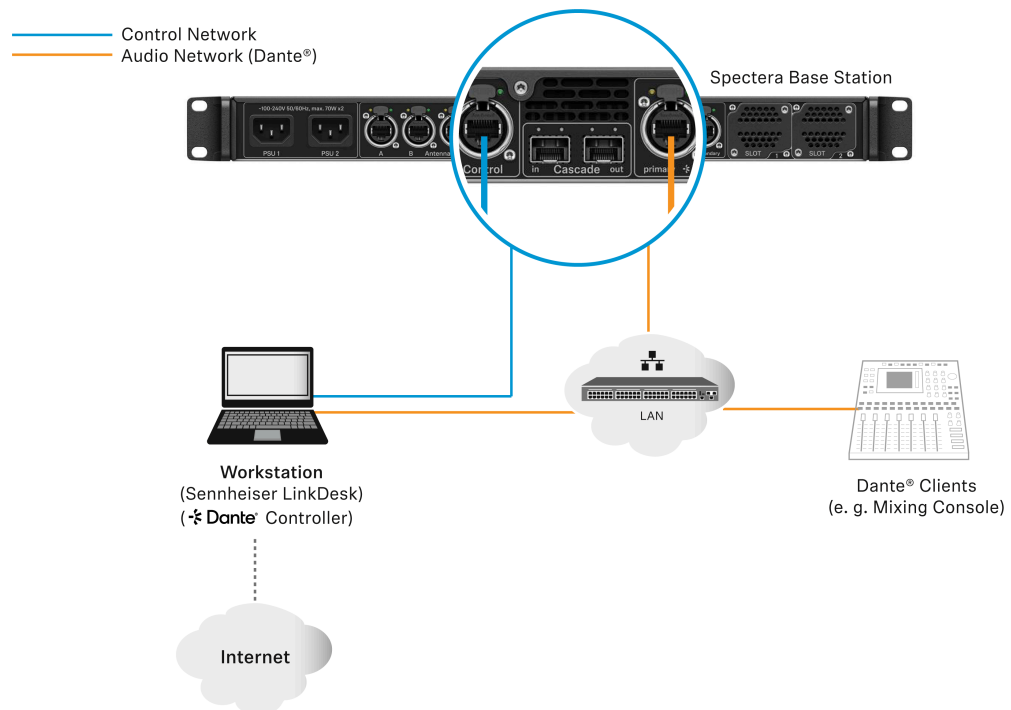

Inside this setup one workstation is used for all client software applications (Sennheiser LinkDesk, Spectera WebUI, Dante® Controller). Either two separated wired network interface are used for control and audio (Dante®) or one interface gets shared. Please be aware that in such setups (typically) no DHCP service is activated. Use either manual IP settings or ZeroConf configuration.

For Internet Connection Sharing typically an existing network connection (Wi-Fi or Ethernet) with Internet access gets shared with another selected network interface of the host.



**In order to share your Internet connection on Windows:**

- ▶ Connect your client device to your host PC using an Ethernet cable. If either device doesn't have a free Ethernet port, use a USB-to-Ethernet adapter.
- ▶ Go to the **Network Connections** menu. The easiest way to get there is by searching for "Network Connections" in the Windows Search box.
- ▶ Right-click on the network adapter connected to the Internet (for example, Wi-Fi or modem), and then select **Properties**.
- ▶ Toggle **Allow other network users to connect** to **ON** from the Sharing tab and select the relevant Ethernet port from the pull-down menu.

**i** Note that, if you have VPN software installed, you may see a lot of virtual Ethernet ports on your list and you'll need to pick the real one.

- ✓ After you click OK, Internet should flow to your client device over its Ethernet port. For more details on sharing an Internet connection please refer to the [Microsoft Support](#) page.

**In order to share your Internet connection on MacOS:**

- ▶ On your Mac, choose **Apple menu > System Settings**.
- ▶ Click on **General** in the sidebar and then on **Sharing** (you may need to scroll down).
- ▶ Turn on **Internet Sharing** and click on **Configure**.
- ▶ Click the **Share your connection** from pop-up menu.
- ▶ Choose the Internet connection you want to share ((For example, if you're connected to the Internet over Wi-Fi, choose Wi-Fi).
- ▶ Under **To devices using**, turn on the port other devices can use to access the shared internet connection. (For example, if you want to share your Internet connection over Ethernet, select Ethernet).

**i** If you're sharing to devices using Wi-Fi, configure the Internet-sharing network, then click **OK**.

- ▶ Click on **Done**.

**i** For more details on sharing an Internet connection please refer to the [Apple Support](#) page.



✓ Your Internet connection will be shared on MacOS/Windows.



## Security guide

This security guide provides essential information and best practices for IT administrators, system integrators, and event technicians to ensure robust security measures are implemented effectively.

Professional audio systems, extensively deployed in environments such as broadcasting, live events, and corporate settings, are increasingly integrated into enterprise networks — making them susceptible to threats like unauthorized access, data interception, and signal interference. To ensure secure deployment and system integrity, Sennheiser enforces the highest security standards across all products, supported by robust protective measures and comprehensive management practices.

- **Security Principles and System Design:**

Sennheiser embeds security from product development through regular risk assessments and secure configurations, following a “security by design” approach. Compliance with international standards ensures consistent protection and proactive threat mitigation.

- **Communication Security and Encryption:**

Industry-standard encryption protocols like AES-256 and TLS protect audio and control data from interception and unauthorized access. Secure methods such as HTTPS and REST APIs are used for networked and third-party integrations.

- **Authentication and Access Control:**

Role-based authentication and device claiming validate users and devices before granting access. Credentials and regular updates maintain system integrity and prevent unauthorized access.

- **Network Configuration and Interfaces:**

Enable only essential ports, segment networks, and apply firewall rules for secure operation. Proper configuration of protocols like Dante®, mDNS, and Bluetooth® is critical for a robust network infrastructure.

This guide provides comprehensive measures to protect professional audio systems from threats through secure design, encryption, authentication, and best practices throughout the system lifecycle.

## Introduction

This security guide provides essential information and best practices for IT administrators, system integrators, and event technicians to ensure robust security measures are implemented effectively.

Professional audio systems, extensively deployed in environments such as broadcasting, live events, and corporate settings, are increasingly integrated into enterprise networks — making them susceptible to threats like unauthorized access, data interception, and signal interference. To ensure secure deployment and system integrity, Sennheiser enforces the



highest security standards across all products, supported by robust protective measures and comprehensive management practices.

- **Security Principles and System Design:**

Sennheiser embeds security from product development through regular risk assessments and secure configurations, following a “security by design” approach. Compliance with international standards ensures consistent protection and proactive threat mitigation.

- **Communication Security and Encryption:**

Industry-standard encryption protocols like AES-256 and TLS protect audio and control data from interception and unauthorized access. Secure methods such as HTTPS and REST APIs are used for networked and third-party integrations.

- **Authentication and Access Control:**

Role-based authentication and device claiming validate users and devices before granting access. b credentials and regular updates maintain system integrity and prevent unauthorized access.

- **Network Configuration and Interfaces:**

Enable only essential ports, segment networks, and apply firewall rules for secure operation. Proper configuration of protocols like Dante®, mDNS, and Bluetooth® is critical for a robust network infrastructure.

This guide provides comprehensive measures to protect professional audio systems from threats through secure design, encryption, authentication, and best practices throughout the system lifecycle.



## Key product security features

Key security features of Spectera devices and software tools are detailed, emphasizing best practices for IT administrators to ensure secure communication and data protection.

Spectera devices (Base Station, DAD, and Mobile Devices (SEK)) and software tools such as **Spectera Base Station WebUI** and **Sennheiser LinkDesk** support enhanced security measures, ensuring both a secure connection between devices via radio and secure data transfer over the network. It offers the following security features:

- **AES-256 Link Encryption:**

The AES-256 Link Encryption protects audio and control communication between devices.

- **Control Protocol Encryption:**

The WebUI is always using encrypted HTTPS communication. The SSCv2 protocol secures the communication between devices and software tools via HTTPS.

- **Device Claiming & Authentication:**

The Device Claiming & Authentication feature ensures authorized control access using passwords.

- **Dante® Media Encryption:**

The Dante® Media Encryption is an optional channel encryption for Dante networks

## AES-256 Link Encryption

All wireless communication between the Spectera devices will be protected with AES-256, a top-tier encryption standard designed to safeguard sensitive data.

Link Encryption includes the following interfaces:

- The connection between the Base Station and Mobile Devices for audio transmission.
- The connection between the Base Station and Mobile Devices for device setting synchronization.

**i** The AES-256 Link Encryption is always enabled and can not be disabled.



## Control Protocol Encryption

All control communication over the network to the Base Station is encrypted and authenticated.

It offers end-to-end security, utilizing HTTPS (TLS 1.3). Communication to the Sennheiser license server is encrypted on application level.

The Protocol Encryption is always enabled and can not be disabled.



## Device Claiming & Authentication

Device claiming and authentication enhance security by requiring password protection for device access and ensuring only authorized users can modify settings through encrypted connections.

The device access via network control API and WebUI of Spectera Base Station and via Sennheiser LinkDesk is password protected, to avoid configuring the device by unauthorized actors inside the network.

The Device Authentication is always enabled and can not be disabled.

### Benefits of device claiming

- **Device Claiming Feature:**

Device claiming is a feature of the Sennheiser LinkDesk and Spectera Base Station WebUI that allows the user to claim ownership of their Sennheiser devices, providing an extra layer of security and control.

- **Device Assignment:**

It allows assigning a device to one or more remote installations, which prevents any unauthenticated device control within the network.

- **Initial Configuration:**

As part of the initial configuration, users claim a device by configuring a mandatory device password.

- **Usability:**

Within an installation, multiple software applications can be used simultaneously with this device password for optimal usability

- **Security Measures:**

Once a device is claimed, its settings can only be viewed and modified via an encrypted connection, which requires entry of the configuration password.



## Dante® Media Encryption (available as of Spectera Dante® firmware Brooklyn3 version 1.1.0)

Dante® Media Encryption extends the security benefits of using Dante® on your network by concealing the media content during transmission between devices.

Dante® utilizes the Advanced Encryption Standard (AES) with a 256-bit key to provide industry-leading media protection.

Concealing the contents of media packets prevents malicious or unauthorized users eavesdropping or interfering with Dante media traffic.

**i** By default, Dante Media Encryption is disabled, since encryption can only be configured by using the Dante Director application. Please refer to the Audinate documentation for detailed information on Dante® encryption, on how to enable and configure encryption and to update the Dante® firmware:

- Dante Media Encryption: [Audinate/Media Encryption](#)
- Updating Dante® firmware: [Dante Updater](#)



## How to use the security features

The following section explains how you can use the various security features both via the device itself and via supported software applications.

### Certificates

Spectera Base Station is using a self-signed certificate for network communication.

The certificate is generated in factory and will be renewed with every factory reset.

**i** Currently it is not possible to replace the certificate with a CA-signed certificate.

When accessing the Spectera WebUI with a browser for the first time you will get a security warning informing about an unknown certificate. The security warning depends on the browser you are using. Depending on your browser, click on Advanced or Show Details (Safari) and then on:

- Microsoft Edge: **Continue to localhost (unsafe)**
- Google Chrome: **Proceed to localhost (unsafe)**
- Firefox: **Accept the Risk and Continue**
- Apple Safari: **[...] visit this Website > Visit Website**
- or similar (other browsers)

In order to prevent man-in-the-middle (MITM) attacks, Sennheiser LinkDesk has some built-in security measures. Because of these measures, you might receive a certificate mismatch warning while working with a Base Station. In some cases, these can occur even though there is actually no security issue. These are:

- The Base Station has been factory reset since the last connect. In this case you can safely confirm the connection and proceed when encountering the mismatch warning.
- A different Base Station has been connected via the same IP address. In this case please verify if the IP Address you are using is indeed the correct IP Address of the intended Base Station.



## Device authentication

The devices access via network is password protected and the device must be claimed in the control software before use.

You can claim the Base Station via:

- LinkDesk (see [Claiming single device \(LinkDesk\)](#)) or
- WebUI (see [Claiming single device \(WebUI\)](#)).

**i** Please note that the new password must meet the following requirements:



- At least ten characters
- At least one lowercase letter
- At least one uppercase letter
- At least one number
- At least one special character: !#\$%&()\*+,-./:;<=>@[!^\_{}~
- Maximum length: 64 characters



## Claiming single device (LinkDesk)

Instructions for claiming a single device in Sennheiser LinkDesk.

### To claim your Base Station:

- ▶ In your production card, activate the function  **DEVICE SYNCHRONIZATION** on the left-hand side of the top bar.
- ▶ Click on the  symbol in the **BASE STATIONS** bar on the right.
- ▶ Enter the correct IP address of the Base Station and click on **Search**.
  - If the device is in a factory default state and the original password is still assigned, it will be automatically detected and applied. Next, a new password has to be set:

**Add base station** ×

**SELECTED DEVICE**

 AVAILABLE  
Spectera base station

Status: Claiming...

**AUTHENTICATION**

Set a new password to secure the device.

New password SHOW

Confirm password

× At least 10 characters  
× At least one lower case and one upper case letter  
× At least one digit and one special character

CANCEL SET PASSWORD

- If the device was previously claimed by another Sennheiser LinkDesk or Spectera WebUI instance, the previously set password must be entered:



**Add base station** [X]

SELECTED DEVICE

AVAILABLE  
Spectera base station

Status: Claiming...

AUTHENTICATION

Enter the device password to authenticate.

Password [SHOW]

[CANCEL] [ENTER]

**i** If you cannot remember the previously set password, please perform a factory reset of the device. After the reset, the default password for Spectera will be automatically applied by the software.

- ▶ Set a new device password (if you are logging in for the first time) or enter the password you have already assigned for authentication (if you have already logged in).

**i** Please note that the new password must meet the following requirements:

- At least ten characters
- At least one lowercase letter
- At least one uppercase letter
- At least one number
- At least one special character: !#\$%&()\*+,-./:;<=>?@[^\_{}~
- Maximum length: 64 characters

✓ Your Base Station has been claimed successfully.



## Claiming single device (WebUI)

Instructions for claiming a single device in Spectera WebUI.

### To claim your Base Station:

- ▶ Enter the following URL into your browser: `https://deviceIP/specterawebui/index.html`

**i** Since the certificate is unknown to your browser, a security warning is displayed the first time you run the application. The security warning depends on the browser you are using.

- ▶ Depending on your browser, click on **Advanced** and then on:
  - **Continue to localhost (unsafe)** (Microsoft Edge)
  - **Proceed to localhost (unsafe)** (Google Chrome)
  - **Accept the Risk and Continue** (Firefox)
  - or similar (other browsers).
- ✓ The WebUI displays the following options depending on the state of the device:
  - If the device is in a factory default state and the original password is still assigned, it will be automatically detected and applied. Next, a new password has to be set:

If the device was previously claimed by another Sennheiser LinkDesk or Spectera WebUI instance, the previously set password must be entered:

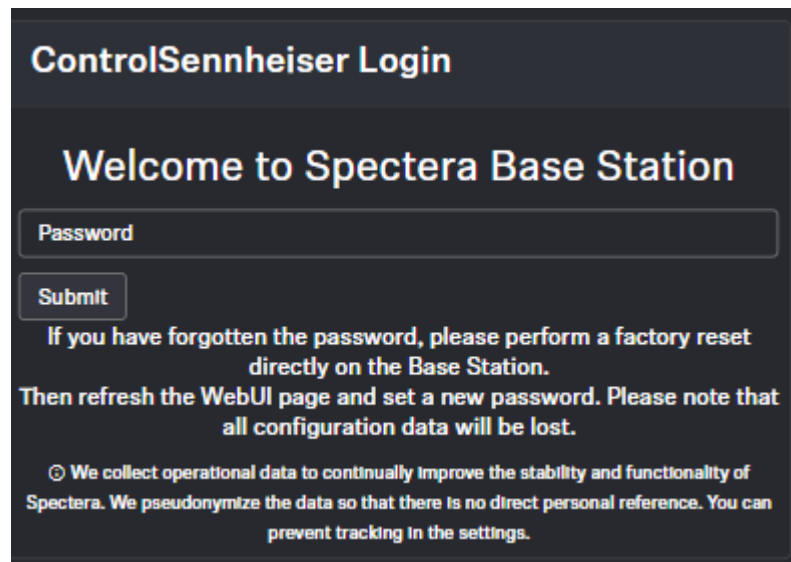

**i** If you cannot remember the previously set password, please perform a factory reset of the device. After the reset, the default password for Spectera will be automatically applied by the software.

- ▶ Set a new device password (if you are logging in for the first time) or enter the password you have already assigned for authentication (if you have already logged in).
- ▶ Click on **Submit**.

✓ Your Base Station has been claimed successfully.



## Resetting the device password (Spectera Base Station)

The device password can only be reset through a factory reset (either performed directly on the device or remotely via WebUI):

**To reset the Base Station remotely:**

- ▶ In the top bar, navigate to **Configuration > Base Station**.
- ▶ Click on **Settings** and then on **Factory Reset**.
- ✓ A countdown timer will be displayed (highlighted in blue).

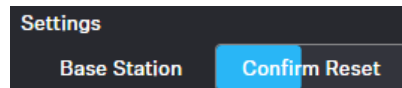

- ▶ Press **Confirm Reset** to confirm the factory reset.

**To reset the Base Station to its factory default settings using the device:**

- ▶ On the Base Station, rotate the jog-dial and navigate to the menu **Reset**.
- ▶ Press the jog-dial to enter the menu.
- ✓ A warning will appear.

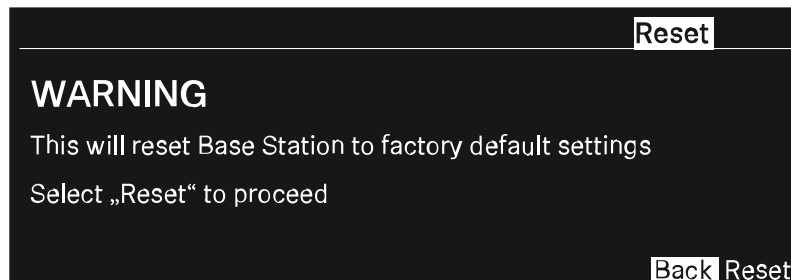

- ▶ Rotate the jog-dial to **Reset**.
- ▶ Press the jog-dial again.
- ✓ The Base Station will be set back to factory settings and reboot.

**i** After rebooting, check the IP address as it may have changed.



## Troubleshooting

This chapter provides a systematic approach for identifying and resolving issues that may occur during the startup or operation of Spectera.

Depending on the specific problem, click on the relevant chapter to identify possible causes and apply potential solutions.

### License activation fails

#### Condition

An error occurs during license activation.

#### Causes

The three most common causes of activation errors are as follows:

1. The Base Station was not connected properly and has no Internet connection (see [Solution 1: Establish a proper connection of the Base Station to the Internet](#)).
2. The license server and/or NTP time server are/is unreachable due to missing port permissions, preventing license key authorization and system clock synchronization (see [Solution 2: Open required ports for license activation and system clock synchronization](#)).
3. The license key was entered incorrectly or has already been activated and is in use with another Base Station (see [Solution 3: Check the activation code and contact support if necessary](#)).

#### Solution 1: Establish a proper connection of the Base Station to the Internet

- ▶ Please connect the Base Station directly to a network with Internet access via a switch or router.

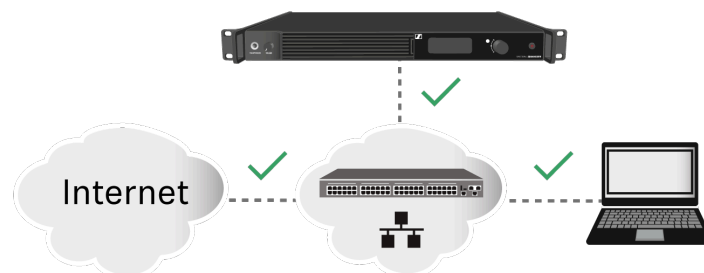



- ▶ Direct connections via laptop etc. are only supported in certain network configuration (see [Sharing Internet connection in small network setups](#)). To eliminate this issue, please avoid a direct connection with your device for license activation.

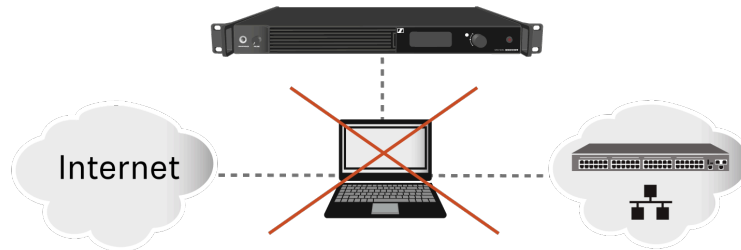

### Solution 2: Open required ports for license activation and system clock synchronization

- ▶ Please contact your IT administrator to provide Internet access to the License Server and any NTP server by opening the required network ports and to provide DNS settings via DHCP to the device.

| Address  | Port | Protocol    | Type    | Service                   | Usage                   |
|--|------|-------------|---------|---------------------------|-------------------------|
| my.nalpeiron.com                               | 80   | HTTPS (TCP) | Unicast | Sennheiser License Server | Activation of devices   |
| ANY (see list of <a href="#">NTP servers</a> ) | 123  | NTP         | Unicast | NTP Time Server           | Synchronize system time |

**i** You can find the complete overview of all ports at [Ports, protocols and services](#).

### Solution 3: Check the activation code and contact support if necessary

- ▶ Please verify that you have correctly entered the Activation Code, or check if someone else has already used the code to activate another Base Station.
- ▶ If the code has already been used for activation, please reach out to Sennheiser Customer Support.



## No device access via the WebUI

### Condition

The device cannot be accessed via the self-hosted WebUI.

### Cause

The wrong device IP or URL schema is being used in the browser.

### Solution

- ▶ Find out the correct IP of the Base Station (see [Network](#)).
- ▶ Enter the correct IP using the correct URL schema depending on the initial firmware version:
  - Firmware  $\leq$  0.8.x use `https://deviceIP/specteracontrol/index.html` .
  - Firmware  $\geq$  1.x.x use `https://deviceIP/` .
- ✔ In some cases the internet browser might have trouble showing the page. Please use the LinkDesk software [sennheiser.com/linkdesk](https://sennheiser.com/linkdesk).



## The Base Station cannot be found

### Condition

The Base Station cannot be found via LinkDesk / WebUI / Dante Manager.

### Cause

The required ports for communication with the Base Station have not been made accessible.

### Solution

- ▶ Depending on the use case, please make the necessary ports available for the Base Station, so that data traffic can flow unrestricted:
  - [Spectera Base Station](#)
  - [Sennheiser LinkDesk](#)
  - Dante®



## 6. Specifications

All technical data and system requirements at a glance.

### Spectera System

#### Transmission scheme

- Multicarrier, TDMA, TDD

#### RF channel

- Bandwidth: 6 or 8 MHz countrywise limited
- Mobiles devices: up to 128 per RF channel
- Audio links: up to 128 per RF channel

#### Radio frequency range

- UHF: 470 - 608 MHz, 630 - 698 MHz
- 1G4: 1350 - 1400 MHz, 1435 - 1525 MHz
- countrywise limited

#### Audio frequency response

- 20 Hz to 20,000 Hz ( $\pm 1$  dB) (Audio link modes with SeDAC and PCM audio codecs only)

#### Encryption

- AES 256 CTR Mode exp. >10k years

#### Audio link modes

| MIC/LINE          | Mono | Max links per RF carrier | Utilized % of RF carrier | Audio codec | La-tency | Range    |
|-------------------|------|--------------------------|--------------------------|-------------|----------|----------|
| Raw Low Latency   | Mono | 8                        | 12.5 %                   | PCM         | 1.0 ms   | Reduced  |
| Raw               | Mono | 16                       | 6.25 %                   | PCM         | 1.6 ms   | Reduced  |
| Live Low Latency  | Mono | 8                        | 12.5 %                   | SeDAC       | 1.0 ms   | Extended |
| Live              | Mono | 16                       | 6.25 %                   | SeDAC       | 1.6 ms   | Extended |
| Live Link Density | Mono | 32                       | 3.13 %                   | SeDAC       | 2.7 ms   | Standard |



| <b>MIC/LINE</b>  | <b>Mono</b> | <b>Max links per RF carrier</b> | <b>Utilized % of RF carrier</b> | <b>Audio codec</b> | <b>La-tency</b> | <b>Range</b> |
|------------------|-------------|---------------------------------|---------------------------------|--------------------|-----------------|--------------|
| Max Range        | Mono        | 16                              | 6.25 %                          | OPUS               | 9.9 ms          | Maximum      |
| Max Link Density | Mono        | 128*                            | 0.78 %                          | OPUS               | 15.2 ms         | Reduced      |

| <b>IEM/IFB</b>         | <b>Mono/ Stereo</b> | <b>Max links per RF carrier</b> | <b>Utilized % of RF carrier</b> | <b>Audio codec</b> | <b>La-tency</b> | <b>Range</b> |
|------------------------|---------------------|---------------------------------|---------------------------------|--------------------|-----------------|--------------|
| Live                   | Mono                | 16                              | 6.25 %                          | SeDAC              | 1.6 ms          | Extended     |
| Live Link Density      | Mono                | 32                              | 3.13 %                          | SeDAC              | 2.7 ms          | Standard     |
| Max Range              | Mono                | 16                              | 6.25 %                          | OPUS               | 9.9 ms          | Maximum      |
| Max Link density       | Mono                | 128*                            | 0.78 %                          | OPUS               | 15.2 ms         | Reduced      |
| Live Ultra Low Latency | Stereo              | 4 (8 ch)                        | 25 %                            | SeDAC              | 0.7 ms          | Extended     |
| Live Low Latency       | Stereo              | 8 (16 ch)                       | 12.5 %                          | SeDAC              | 1.1 ms          | Extended     |
| Live                   | Stereo              | 16 (32 ch)                      | 6.25 %                          | SeDAC              | 1.6 ms          | Standard     |
| Live Link Density      | Stereo              | 32 (64 ch)**                    | 3.13 %                          | SeDAC              | 2.7 ms          | Reduced      |

\* Base Stations have 32 audio outputs, for 128 links in a single RF channel, 4 Base Stations and firmware update with cascade port function are required (future release)

\*\* Base Stations have 32 audio inputs, for 32 stereo links (64 ch) in a single RF channel, 2 Base Stations and firmware update with cascade port function are required (future release)



## Base Station

### General

#### RF channels

- 2

#### Audio inputs and outputs

- Input: up to 32 channels
- Output: up to 32 channels
- Individually selectable from digital audio interfaces

#### Digital audio inputs and outputs

- Dante®
  - Ethernet, 1 Gbit/s
  - 2× ruggedized RJ45 (Primary and Secondary)
  - 32 In, 32 Out, 48 kHz or 96 kHz, 16/24/32 bit
- MADI (AES10)
  - 2× Expansion Slots for MADI Card OM (optical fiber multimode) or MADI Card BNC (separate accessories)
  - 32 In, 32 Out, 48 kHz or 96 kHz, 16/24 bit
- Individual sample rate for each interface

#### Headphone output

- 6.3 mm jack
- 2x 50 mW at 32  $\Omega$  -40 dB THD (1%) at 1 kHz

#### Antenna connections

- 4 × ruggedized RJ45, PoE supply for up to 4 DAD UHF/1G4

#### Antenna cable

- Category 5e or higher, S/UTP (maximum 100 m)

#### Word clock input

- Input: BNC, 75  $\Omega$
- Output: BNC, 75  $\Omega$
- Sampling rates: 48 kHz, 96 kHz

#### Control

- Ethernet, 1 Gbit/s, ruggedized RJ45



**Cascade in / out\***

- 2 × SFP+ cages (to be equipped with 10 Gbit/s modules)

**Power supply**

- 2 x internal redundant
- 100 to 240 V AC, 50/60 Hz

**Power consumption**

- 70 W

**Power plug**

- 3-pin, protection class I as per IEC/EN 60320-1

**Dimensions (H × W × D with mounting elements)**

- 44 × 483 × 373 mm (1.73" x 19.02" x 14.69")

**Weight**

- Approx. 6.3 kg (13.89 lbs) (without accessories)

**Temperature**

- Operation: -10 °C to +50 °C (14 °F to 122 °F)
- Storage: -25 °C to +70 °C (-13 °F to 158 °F)

**Relative air humidity**

- 25 % to 95 % (non-condensing)

**Dripping and splashing liquids**

- The product must not be exposed to dripping and splashing liquids (IP2X)

\*Software update with cascade port function required (future release)

**Ports - Base Station Control Network Interface**

| Address  | Port | Protocol    | Type    | Service                   | Usage                 |
|--|------|-------------|---------|---------------------------|-----------------------|
| <b>Requests from device to ...</b>             |      |             |         |                           |                       |
| Sennheiser License Server address <sup>1</sup> | 80   | HTTPS (TCP) | Unicast | Sennheiser License Server | Activation of devices |



| Address   | Port | Protocol    | Type      | Service                           | Usage  |
|---|------|-------------|-----------|-----------------------------------|--|
| ANY address of time server (see list of <a href="#">NTP time server pools</a> ) | 123  | NTP         | Unicast   | NTP Time Server                   | Synchronize system time                          |
| 224.0.0.251   | 5353 | mDNS (UDP)  | Multicast | mDNS, DNS-SD                      | (optional - if desired) Device/Service Discovery |
| <b>Requests to device from ...</b>  |      |             |           |                                   |  |
| ANY IP of SSCv2 client  | 443  | HTTPS (TCP) | Unicast   | SSCv2 - Spectera Base Station API | Monitor+Control communication from clients       |
| <sup>1</sup> my.nalpeiron.com   |      |             |           |                                   |  |

### NTP time server pools

- pool.ntp.org
- time.nist.gov
- time.aws.com
- time.cloudflare.com

### Ports - Base Station Dante® Network Interfaces

Spectera Base Station requires several ports to be opened for both Dante® Network Interfaces to operate properly. For the list of ports and more detailed information, please refer directly to the Dante® website: [Audinate FAQ - Networks and Switches](#).



## SEK

### RF transmission power

- up to 50 mW; countrywise limited

### RF channels

- 1

### Headphone output

- 3.5 mm TRS jack
- 2 × 300 mW RMS (32 Ω, -40 dB THD, 1 kHz)

### Microphone / Instrument / Command input

- 3-pin audio socket

Solder side

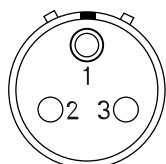

| Assignment | Function              |
|------------|-----------------------|
| Pin 1      | Ground & housing      |
| Pin 2      | Line In / command*    |
| Pin 3      | Mic In & bias voltage |
| Housing    | Ground                |

\*for auto line detection short pin 1 and 3

### Power supply

- BA 70 rechargeable battery pack

### Battery operating time

- up to 7 h (unidirectional microphone use)
- up to 6 h (unidirectional IEM use)
- up to 5 h (bidirectional use)

### Dimensions

- approx. 83 x 62 x 21 mm (3.39" x 2.44" x 0.83") (without antenna)



**Weight**

- approx. 178 g (0.39 lbs) (with BA 70)
- approx. 144 g (0.32 lbs) (without BA 70)

**Temperature**

- Operation: -10 °C to +50 °C (14 °F to 122 °F)
- Storage: -25 °C to +70 °C (-13 °F to 158 °F)

**Relative air humidity**

- 25 % to 95 % (non-condensing)



## DAD

### RF transmission power

- up to 100 mW; countrywise limited

### RF channels

- 1

### Base Station connection

- Ruggedized RJ45 including PoE, max. 100 m cable, CAT5e or better, 1 Gbit/s

### Power consumption

- PoE class 2 (< 6.5 W)

### Apex angle vertical

- vertical
  - UHF: 65 °
  - 1G4: 62 °
- horizontal
  - UHF: 109 °
  - 1G4: 93 °

### Front to back ratio

- UHF: 15 dB
- 1G4: 17 dB

### Gain

- UHF: 5 dB
- 1G4: 6.5 dB

### Threads for tripod mounting

- Yes / Adapter 3/8" to 5/8"

### Dimensions

- UHF: 349 x 292 x 39 mm (13.74" x 11.5" x 1.54")
- 1G4: 231 x 205 x 39 mm (9.09" x 8.07" x 1.54")

### Weight

- UHF: 676 g (1.49 lbs)
- 1G4: 534 g (1.18 lbs)



**Temperature**

- Operation: -10 °C to +50 °C (14 °F to 122 °F)
- Storage: -25 °C to +70 °C -13 °F to 158 °F)

**Relative air humidity**

- 25 % to 95 % (non-condensing)

**IP class**

- IP54



## Specifications

System requirements and ports requirements for inbound and outbound traffic.

### System requirements

- Intel i5 Dual Core processor/M1 Mac/or similar
- 16 GB RAM
- Gigabit LAN interface
- Windows® 10 or higher
- Mac OS Big Sonoma or later
- IPv4 network

### Supported web browsers for Spectera WebUI

- Google Chrome: 125 or later
- Microsoft Edge: 125 or later
- Mozilla Firefox: 128 or later
- Apple Safari: 17 or later
- JavaScript must be activated

### Port requirements

| Address   | Port | Protocol    | Type    | Service                           | Usage                                    |
|---|------|-------------|---------|-----------------------------------|--|
| <b>Requests from host to ...</b>                |      |             |         |                                   |  |
| ANY IP of a Base Station                        | 443  | HTTPS (TCP) | Unicast | SSCv2 - Spectera Base Station API | Monitor+Control communication to devices |
| Sennheiser User Insights addresses <sup>1</sup> | 443  | HTTPS (TCP) | Unicast | Sennheiser User Insights          | Analytics of usage and operational data  |

<sup>1</sup> sennheiseruserinsights.matomo.cloud  
cdn.matomo.cloud



## CHG 70N-C charger

### Power supply

- 12 V DC (single unit or cascade of up to 5 units)
- PoE IEEE 802.3af Class 0 (CAT5e or higher), single unit only

### Current consumption

max. 3.5 A for a cascade of up to 5 units

### Ethernet

- RJ-45 socket, IEEE802.3
- 100Base-TX (half+full duplex)
- 10Base-T (half+full duplex)

### Dimensions

Approx. 200 x 104 x 116 mm

### Weight

Approx. 640 g, without power supply unit

### Charging slots

2

### Charging capacity per slot

- BA 70 rechargeable battery **or**
- EW-DX SK with BA 70 **or**
- EW-DX SKM with BA 70**or**
- SPECTERA SEK UHF/1G4

### Charging voltage

4.35 V

### Charging current

min. 344 mA

max. 860 mA

### Full charging time

Max. 3.5 h

### Temperature range

- Charging: -10 °C to +50 °C
- Storage: -20 °C to +70 °C



**Relative humidity**

Max. 95% (non-condensing)



## BA 70 rechargeable battery

### Rated capacity

1720 mAh

### Nominal voltage

3.8 V

### Charging voltage

max. 4.35 V

### Charging time

Typically 3 h @ room temperature

### Dimensions

Approx. 54 x 30 x 15

### Weight

Approx. 33 g

### Temperature range

- Charging: 0 °C – +55 °C (32 °F – 131 °F)
- Discharging: -10 °C to +55 °C
- Storage: -10 °C to +45 °C

### Relative humidity

- Charging/discharging: 25% to 95%, non-condensing
- Storage: 30% to 70%, non-condensing



## L 70 USB charger

### **Charging capacity**

2 Sennheiser BA 70 rechargeable battery packs

2x Sennheiser battery BA 62 with 2x L 70 adapter BA 62

### **Input voltage**

Typically 5 V

### **Input current**

max. 2 A

### **Charging voltage**

nominally 4.35 V

### **Charging current**

max. 860 mA per battery pack

### **Charging time**

max. 3.5 h with NT 5-20 UCW power supply unit

### **Temperature range**

- Charging: 0 °C to +55 °C
- Storage: -20 °C to +70 °C

### **Relative humidity**

Max. 95% (non-condensing)

### **Dimensions**

100 × 35 × 70 mm (1 3/4" x 3 7/8" x 7 3/16")

### **Weight**

Approx. 86 g



## Modular L 6000 charger

### Charging capacity

- Up to 8 rechargeable batteries (BA 60, BA 61, BA 62 and BA 70) across 4 exchangeable charging modules (LM 6060, LM 6061, LM 6062 and LM 6070)

### Charging times at 20° C

- BA 60
  - 80%: approx. 1:15 h (approx. 4:45 h operating time)
  - Full: approx. 2:30 h
- BA 61
  - 80%: approx. 1:45 h (approx. 5:00 h operating time)
  - Full: approx. 3:15 h
- BA 62
  - 80%: approx. 1:15 h (approx. 9:30 h operating time)
  - Full: approx. 2:45 h
- BA 70
  - 80%: approx. 1:45 h
  - Full: approx. 3:30 h

### Charging temperature range

- 0 to 50 °C (32 °F to 122 °F)

### Charging status display

- Multi-colored

### Network

- IEEE 802.3-2002 (10/100 Mbit/s), shielded RJ-45 connection

### Power supply

- AC 100 – 240 V, 50/60 Hz

### Maximum power consumption

- 85 W

### Minimum power consumption

- 1 W

### Power plug

- 3-pin, protection class I as per IEC/EN 60320-1



**Dimensions (H × W × D with mounting elements)**

- 44 x 483 x 373 mm

**Weight**

- 5.1 kg



## LM 6060 | LM 6061 | LM 6062 | LM 6070 charging modules

### Dimensions (H × W × L)

- 44 x 99 x 182 mm

### Weight

- 144 g

### Rechargeable battery type

- LM 6060: 2× BA 60
- LM 6061: 2× BA 61
- LM 6062: 2× BA 62
- LM 6070: 2× BA 70

