

SpeechLine Digital Wireless

PDF Export of the Original HTML Manual



Contents

1. Preface.....	7
2. System information.....	8
SpeechLine Digital Wireless: System informationen.....	8
Focus on the spoken word.....	10
SpeechLine Digital Wireless – the professional solution for speakers, lecturers and presenters.....	11
Typical applications.....	12
What are the features of SpeechLine Digital Wireless?.....	15
The Products of the SpeechLine Digital Wireless Series.....	18
The SL Rack Receiver DW receiver.....	18
SL Multi-Channel Receiver DW.....	19
The handheld transmitter.....	20
The bodypack transmitter.....	21
The wireless SL Tablestand 133-S DW.....	22
The wireless SL Tablestand 153-S DW.....	23
The wireless SL Boundary 114-S DW.....	24
The CHG 2 charger.....	25
The CHG 2N charger.....	26
The CHG 4N charger.....	27
The CHG 2W charging base.....	28
Accessories.....	29
The clip-on and headset microphones.....	29
GA 4 mounting kit.....	30
The AWM 2 antenna wall mount.....	31
The AWM 4 antenna wall mount.....	32
The SL PASC 2 passive antenna splitter.....	33
The SL PASC 4 passive antenna splitter.....	34
Antenna cables.....	35
3. System planning.....	36
Planning.....	36
Country-Specific Variants.....	37
Number and size of the rooms.....	40
Shared use of the 1.9 GHz frequency band.....	41
Analysis of the environmental conditions.....	44
Recommendations on antenna mounting.....	45



Antenna setup and planning for SpeechLine Digital Wireless.....	45
Antenna mounting options.....	46
Option 1: Connecting the AWM 2 or AWM 4 antenna wall mount directly to the receiver(s).....	47
Option 2: Combining multiple links to one AWM 2/AWM 4.....	50
Option 3: Rack mounting - front.....	54
Option 4: Rack mounting - rear.....	55
Further important information on antenna usage.....	56
Multi-room mode.....	58
Single-room setup with SL Rack Receiver DW only.....	58
Single-room setup with SL Multi-Channel Receiver DW only.....	60
Single-room setup with both SL Rack Receiver DW and SL Multi-Channel Receiver DW.....	61
Multi-Room Mode setup with SL Rack Receiver DW only.....	62
Multi-Room Mode setup with SL Multi-Channel Receiver DW only.....	63
Multi-Room Mode setup with both SL Rack Receiver DW and SL Multi-Channel Receiver DW.....	65
4. User Manual.....	67
SL Rack Receiver DW.....	67
Product overview and operating elements – front panel.....	67
Product overview and connections – rear panel.....	69
Meaning of the Status LED.....	70
Connecting the receiver.....	73
Controlling and monitoring the receiver via the network.....	76
Updating the firmware.....	79
Setting up the receiver.....	80
Installing receivers in a rack.....	82
Switching the receiver on and off.....	86
Displays on the receiver’s display panel.....	87
Using the operating menu of the receiver.....	90
SL MCR DW.....	95
Product overview and operating elements.....	95
Directivity of the integrated antennas.....	96
Connecting the receiver.....	99
Mounting the receiver.....	102
Putting the receiver into operation.....	109
Controlling and monitoring the receiver via the network.....	110



Meaning of the status LEDs.....	111
Updating the firmware.....	117
The SL Handheld DW.....	118
Product overview.....	118
Displays on the display panel.....	120
Removing/inserting the accupack.....	121
Switching the handheld transmitter on and off.....	122
Meaning of the status LED.....	123
Using the handheld transmitter.....	126
MUTE switch.....	128
Updating the firmware.....	129
The SL Bodypack DW.....	130
Product overview.....	130
Displays on the display panel.....	132
Removing/inserting the accupack.....	133
Connecting the clip-on microphone or the headset microphone to the bodypack transmitter.....	135
Switching the bodypack transmitter on and off.....	136
Meaning of the status LED.....	137
MUTE switch.....	140
Updating the firmware.....	141
The SL Tablestand 133-S DW.....	142
Product overview.....	142
Removing/inserting the BA 40 accupack.....	144
Charging the table stand.....	145
Meaning of the charge level LEDs on the table stand.....	147
Connecting the goose neck microphone.....	148
Switching the table stand on/off.....	149
Muting the table stand.....	150
Updating the firmware.....	151
The SL Tablestand 153-S DW.....	152
Product overview.....	152
Removing/inserting the BA 40 accupack.....	154
Charging the table stand.....	155
Meaning of the charge level LEDs on the table stand.....	157
Connecting the goose neck microphone.....	158
Switching the table stand on/off.....	159



Muting the table stand.....	160
Updating the firmware.....	161
The SL Boundary 114-S DW.....	162
Product overview.....	162
Removing/inserting the BA 40 accupack.....	164
Charging the boundary microphone.....	165
Meaning of the charge level LEDs.....	168
Switching the boundary microphone on/off	169
Muting the boundary microphone.....	170
Updating the firmware.....	171
Pairing.....	172
Identifying paired devices.....	172
Pairing a receiver with a transmitter.....	174
Performing a walk test (reception quality).....	177
Performing a walk test with the SL MCR DW in the Control Cockpit.....	177
Performing a walk test with the SL Rack Receiver DW in the Control Cockpit	179
Performing a walk test with the SL Rack Receiver DW on the device.....	180
The Headmic 1 headset microphone.....	182
Preparing the headset microphone for use.....	182
Changing the microphone position (left/right).....	183
Adjusting the microphone boom and the neckband.....	185
Using the frequency response caps.....	187
Using the windshield.....	188
Attaching the connection cable to clothing.....	189
Connecting the microphone to the SL Bodypack DW.....	190
The MKE 1 clip-on microphone.....	191
Treble boost.....	191
Attaching the microphone.....	192
Connecting the microphone to the SL Bodypack DW.....	193
The CHG 2 charger.....	194
Product overview.....	194
Connecting the charger to the power supply system.....	195
Charging the accupack in the charger.....	196
The CHG 2N charger.....	197
Product overview.....	197
Connecting the charger to the power supply system.....	199
Charging the accupack in the charger.....	201



Meaning of the charging slot status LEDs.....	202
Controlling and monitoring the charger over the network.....	203
Activating power saving mode.....	210
Updating the firmware.....	211
The CHG 4N charger.....	212
Product overview.....	212
Connecting the charger to the power supply system.....	214
Charging the accupack in the charger.....	216
Meaning of the charging slot status LEDs.....	217
Controlling and monitoring the charger over the network.....	218
Activating power saving mode.....	225
Updating the firmware.....	226
The CHG 2W charging base.....	227
Product overview.....	227
Connecting the charging base to the power supply system.....	228
Charging a device using the charging base.....	229
Meaning of the status LEDs on the charging surfaces.....	231
AWM 2 / AWM 4 remote antennas.....	232
Product overview.....	232
Attaching the antennas	233
Connecting the antenna cables.....	234
Mounting the antenna on a stand or on the wall.....	236
The SL PASC 2 passive antenna splitter/combiner.....	237
Connectors on the rear of the device.....	237
The SL PASC 4 passive antenna splitter/combiner.....	238
Connectors on the rear of the device.....	238
Installing antenna splitters in a rack.....	239
5. Regulatory Information.....	242
6. Contact.....	252



1. Preface

PDF Export of the Original HTML Manual

This PDF document is an automatic export of an interactive set of HTML manuals. Some content and interactive elements may not be included in the PDF because they cannot be displayed in this format. In addition, automatically generated page breaks may cause related content to be slightly shifted. We can therefore only guarantee the completeness of the information in the HTML manual and recommend using it. You can find it in the Documentation Portal at www.sennheiser.com/documentation.



2. System information

All information about the product and available accessories at a glance.

SpeechLine Digital Wireless: System informationen

For more information about the individual **products** in the SpeechLine Digital Wireless series, see [The Products of the SpeechLine Digital Wireless Series](#).

For information about the available accessories, see [Accessories](#).

For information about **planning** a complete SpeechLine Digital Wireless system, see [System planning](#).

You can find **instruction manuals** for all products in the SpeechLine Digital Wireless series under [User Manual](#).



SpeechLine Digital Wireless is the first digital wireless microphone system designed specifically for the spoken word. SpeechLine Digital Wireless is a future-proof solution that's easy to set up, use and manage and that lets the presenter concentrate on their words, not on the technology.

SpeechLine Digital Wireless comprises mobile transmitters (handheld or bodypack) tailored for speech applications, speech optimized condenser microphones (a microphone capsule for the handheld transmitter, a clip-on or headset microphone for the bodypack transmitter) and a rack receiver. The transmitters are powered by rechargeable lithium-ion accupacks with a battery life of more than 15 hours. The accupacks can be recharged with the charger or via USB. SpeechLine Digital Wireless has an automatic frequency management feature that automatically searches for free frequencies on site, thus eliminating the need for time-consuming frequency planning in advance. In addition, the automatic interference management function always ensures a stable wireless connection, and thus provides maximum transmission reliability. The automatic microphone sensitivity adjustment makes the setup even more convenient since there is no need for manual level adjustment. What



is more, network integration enables SpeechLine Digital Wireless to be remote controlled and monitored using a media control system (e.g. AMX, Crestron) or the browser-based Sennheiser Control Cockpit software.



Focus on the spoken word



The spoken word is and remains the most personal and powerful instrument of communication we know. It allows us to convince people, to impart knowledge and to voice opinions, thoughts and views as well as emotions. That is why it is so important that none of the content is lost when audio devices such as wireless microphones and the associated receivers are used.



SpeechLine Digital Wireless – the professional solution for speakers, lecturers and presenters



The best wireless microphones and receivers are those which the speaker does not need to think about because they are ready for immediate use, automatically establish the most reliable radio link and provide maximum transmission reliability in every application and all day long. The microphones and the receiver of the SpeechLine Digital Wireless series are designed for optimum speech intelligibility, offer maximum security thanks to encrypted transmission, and provide for seamless integration into an existing conference system, a media control system or a telephone system. The unobtrusive design blends in perfectly with your conference or training room, the auditorium or the presentation stage.



Typical applications

Excellent speech intelligibility, easy handling and convenient control are to the fore at all times, regardless of whether SpeechLine Digital Wireless is used in presentations, meetings or telephone conferences.

Presentations



In the case of a presentation held before a large audience, such as in an auditorium or a large conference room, it is essential that every word can be understood. If active speakers walk around during the presentation or turn away from the audience, they are completely intelligible at all times thanks to SpeechLine Digital Wireless.



Meetings



Good speech intelligibility and easy handling of the microphone system are important requirements for professional meetings. The larger the conference or training room, the more helpful is an audio system which enhances speech intelligibility. In large conference rooms in particular, a speaker seated at one end is difficult to understand at the other end. When the speaker turns in different directions, for example in order to address individual participants, he is difficult to understand in the other direction in each case. SpeechLine Digital Wireless does not restrict the freedom of movement of active speakers.



Teleconferences



In modern office life, teleconferences are becoming more and more important for the cooperation of international teams. As a telephone alone can only offer inadequate speech transmission for all participants in the room, the SpeechLine Digital Wireless system can easily be connected to an existing teleconference unit such as the Sennheiser TeamConnect system. This processes the audio signals and establishes the connection to the remote participants.



What are the features of SpeechLine Digital Wireless?

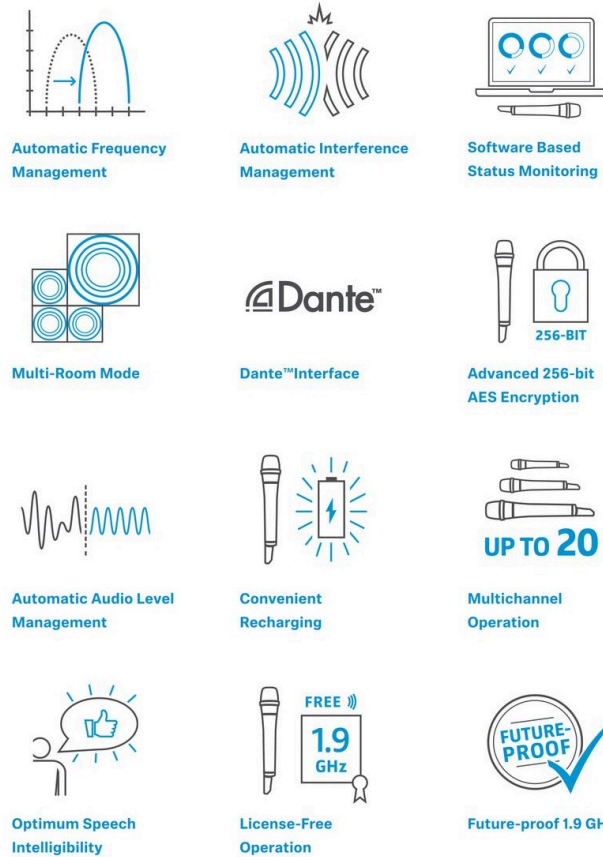

Automatic frequency management

SpeechLine Digital Wireless finds free transmission frequencies reliably and fully automatically. Manual intervention is not necessary in the search for a free frequency. This means that your wireless microphone and the receiver are ready for use within an extremely short time: connect them, switch them on – and that’s all.

The transmitter and the receiver are pre-paired at the factory and immediately work together. If necessary, this pairing can be changed at any time, for example in order to switch from a clip-on microphone to a handheld transmitter. It is also possible to use several transmitters, such as when each lecturer at a university uses their own microphone.

Automatic microphone sensitivity adjustment

It is not necessary to manually adapt the input sensitivity to the microphone used, and the audio level is automatically adjusted for different speakers. In addition, different sound profiles are defined for male and female voices. In this way, the high-quality microphones of the SpeechLine Digital Wireless series can unleash their full potential without distortion.



Automatic level management

The level of the audio signal is automatically optimally adjusted so that the speaker's voice can be heard loud and clear. If necessary, the receiver's output level can be manually adapted to the input of the mixing console or amplifier.

Automatic interference management

The system immediately reacts to interfering signals such as those coming from DECT telephones by automatically changing the frequency. This prevents interference and audio dropouts and ensures an uninterrupted connection. The automatic frequency change is not noticed by the user of the microphone or by the audience. If several radio links are active for different speakers at the same time, the respective frequencies are automatically selected so that they cannot interfere with each other. The frequencies are immediately adapted to newly added radio links without interfering with the ongoing transmission or even interrupting it.

Future-proof, license-free audio transmission

SpeechLine Digital Wireless operates in the future-proof 1.9 GHz frequency band. Transmission in this band is not affected by regulatory changes of the digital dividend or by the auctioning of frequencies. In addition, the frequencies in this band can be used without a license. With SpeechLine Digital Wireless, you don't have to fear changes to the frequency band used which could possibly mean having to buy new audio equipment. The acquisition of a SpeechLine Digital Wireless system is a future-proof investment.

To allow optimum use of the 1.9 GHz frequency band, SpeechLine Digital Wireless offers two operating modes: For up to 20* links used in parallel, the **Adaptive Power Mode** ensures extremely easy startup and a reliable maximum range. The **Multi-Room Mode** allows you to adjust the transmission power to allow for a considerably larger number of links. These adjustment options make SpeechLine Digital Wireless the optimum solution for a great variety of projects with widely differing installation sizes at the same location.

* depending on the locally approved variant

Tap-proof audio transmission

The encrypted, tap-proof transmission of information is especially important in the corporate environment. This is why we decided to use 256-bit AES encryption when developing the SpeechLine Digital Wireless series. Here the security of wireless transmission is ensured by the generation of a new key each time a new connection is made between transmitter and receiver. At every meeting and every conference, this guarantees that only the receiver paired with the transmitter is able to decode the audio signal. Encryption cannot be deactivated – making SpeechLine Digital Wireless secure at all times.



Extremely long battery life

It is not necessary to replace or recharge the accupack during operation. The battery life is about 15 hours – enough for even a very long conference day. Intelligent energy management using adaptive transmission power maximizes the battery life.

To charge the accupacks, it is not necessary to remove them from the transmitters. They can be recharged using the optional CHG 2 charger for handheld and pocket transmitters or directly via the supplied USB charging cable.

Easy control using the Sennheiser Control Cockpit software

Sennheiser Control Cockpit is the central software for easy handling, control and maintenance of the entire SpeechLine Digital Wireless system. The easy-to-use Sennheiser Control Cockpit software provides a global overview of all network enabled SpeechLine Digital Wireless devices at all times. It shows all status information at a glance and makes setting adjustments for one or multiple devices at the same time very easy. The room overview connects the locations of all components to their respective status information, so the user always knows the location and status of a specific device. The Sennheiser Control Cockpit is accessible everywhere in the intranet via a web browser across all platforms. As a result, the software allows you to manage even huge setups with hundreds of devices with minimal effort.

sennheiser.com/control-cockpit-software



The Products of the SpeechLine Digital Wireless Series

i For information about the available accessories, see [Accessories](#).

The SL Rack Receiver DW receiver



The 9.5" rack receiver (SL Rack Receiver DW) is the core of the SpeechLine Digital Wireless system. Thanks to the bi-directional communication between the rack receiver and the transmitter, all transmitter settings can be adjusted on the receiver. The receiver's automatic frequency management eliminates the need for manual frequency setting and the automatic interference management guarantees maximum transmission reliability. The user-friendly pairing function ensures a reliable connection between transmitter and receiver. Network integration enables the receiver to be remote controlled and monitored using a media control system (e.g. AMX, Crestron) or the Sennheiser Control Cockpit software. The antenna can either be mounted to the rear of the receiver or to the front of a rack. Antenna cables of different lengths also allow mounting the antenna remotely from the receiver. The antenna cables are available as accessories.

i For information about installation and operation, see the instruction manual: [SL Rack Receiver DW](#)



SL Multi-Channel Receiver DW

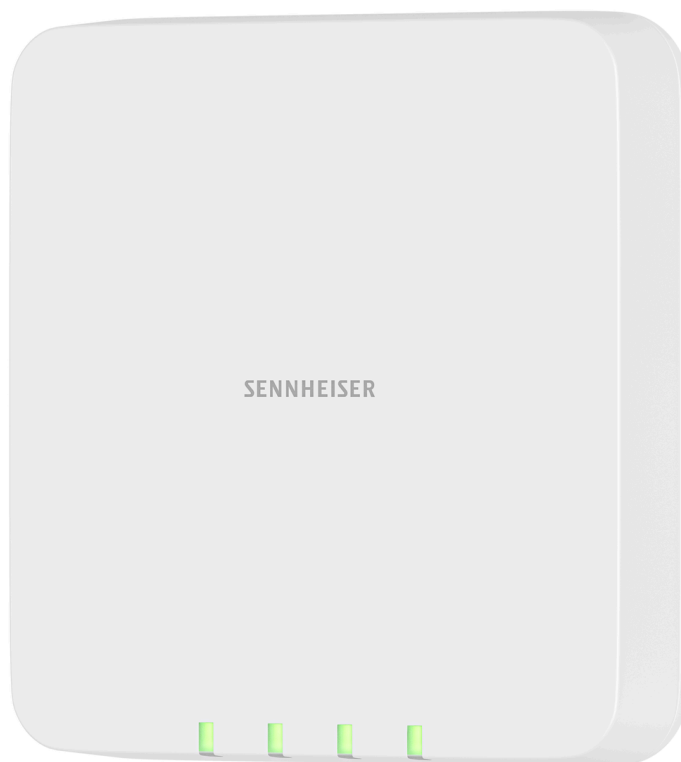

The SpeechLine Multi-Channel Receiver with its 2 or 4 channels is the perfect addition to the SpeechLine series. Thanks to its unobtrusive design, the Multi-Channel Receiver can be installed quickly and easily in any room, whether on the wall or ceiling. The device can be operated with a single network cable, thanks to PoE and Dante. Complex analog audio cabling is a thing of the past. The Multi-Channel Receiver also offers a convenient solution for existing installations. Thanks to an integrated auto mixer and the analog mix output, all audio channels can be used simply as a sum signal. The audio mix is also available digitally via Dante, which allows an extension of the existing setup without exchanging the DSP. Due to the bidirectional communication between receiver and transmitter, all settings of the mobile transmitters can easily be made in the Sennheiser Control Cockpit. The receiver's automatic frequency management eliminates the need for manual frequency setting and the automatic interference management guarantees maximum transmission reliability. The user-friendly pairing function ensures a reliable connection between transmitter and receiver. Network integration also makes it possible to remotely control and monitor the receiver via a media control system (e.g. AMX, Crestron). Due to the integrated antennas, a complex antenna installation is no longer necessary.

i For information about installation and operation, see the instruction manual: [SL Rack Receiver DW](#)



The handheld transmitter



The handheld transmitter (SL Handheld DW) is ideal when several persons are speaking at the same time, such as in interviews or when queries come from the audience. You can replace the microphone capsule if necessary. The handheld transmitter is supplied with the high-quality MME 865-1 microphone capsule. The MME 865-1 has excellent presence and high feedback rejection and is specially designed for speech applications.

Thanks to its easy handling, the handheld transmitter is available to the speaker for immediate use, and no further instruction is necessary. The functions of the handheld transmitter have been reduced to a minimum to allow stress-free speaking during the presentation and to ensure that the speaker is not distracted by unnecessary operating options.

i For information about installation and operation, see the instruction manual: [The SL Handheld DW](#)



The bodypack transmitter



The compact, robust bodypack transmitter (SL Bodypack DW) is compatible with all Sennheiser headset and clip-on microphones (e.g. Headmic 1 or MKE 1). Thanks to the bi-directional communication between the transmitter and the receiver, no settings need to be adjusted on the transmitter. The transmitter's LC display indicates the link name, the battery status and the reception quality. The functions of the bodypack transmitter have been reduced to a minimum to allow stress-free speaking during the presentation and to ensure that the speaker is not distracted by unnecessary operating options. With the easy-to-access mute switch, the transmitter can be muted if necessary.

i For information about installation and operation, see the instruction manual: [The SL Bodypack DW](#)



The wireless SL Tablestand 133-S DW



The wireless SL Tablestand 133-S DW is designed for your speech. It is compatible with all Sennheiser XLR-3 goose neck microphones, making it ideal for podium discussions, speeches and presentations.

Because it is completely cable free, the SL Tablestand 133-S DW is extremely versatile and suited for a wide range of applications.

The SL Tablestand 133-S DW can be charged either wirelessly or via USB. The CHG 2W wireless charging base for two mobile devices is available separately. The SL Tablestand 133-S DW is delivered with a rechargeable battery that lasts up to 10 hours.

The Sennheiser Control Cockpit software can be used to monitor and control the wireless table stand remotely.

i For information about installation and operation, see the instruction manual: [The SL Tablestand 133-S DW](#)



The wireless SL Tablestand 153-S DW



The wireless SL Tablestand 153-S DW is designed for your speech. It is equipped with an XLR-5 socket to provide a hardwired connection to the MEG 14-40-L-II B goose neck microphone.

Because it is completely wireless, the SL Tablestand 153-DW is the perfect solution for ad hoc press conferences or panel discussions in any environment.

The SL Tablestand 153-S DW can be charged either wirelessly or via USB. The CHG 2W wireless charging base for two mobile devices is available separately. The SL Tablestand 153-S DW is equipped with dedicated charging status LEDs to clearly show the battery life.

The Sennheiser Control Cockpit software can be used to monitor and control the SL Tablestand 153-S DW remotely.

i For information about installation and operation, see the instruction manual: [The SL Tablestand 153-S DW](#)



The wireless SL Boundary 114-S DW



The wireless SL Boundary 114-S DW boundary microphone is designed for your speech.

Because it is completely cable free, the SL Boundary 114-S DW is extremely versatile and suited for a wide range of applications.

The SL Boundary 114-S DW can be charged either wirelessly or via USB. The CHG 2W wireless charging base for two mobile devices is available separately. The SL Boundary 114-S DW is delivered with a rechargeable battery that lasts up to 10 hours.

The Sennheiser Control Cockpit software can be used to monitor and control the wireless boundary microphone remotely.

i For information about installation and operation, see the instruction manual: [The SL Boundary 114-S DW](#)



The CHG 2 charger



The CHG 2 charger allows you to simultaneously charge up to two transmitters of the SpeechLine Digital Wireless series. A bi-color LED at each charging slot provides information on the current charge status. The charger has universal charging slots for charging both handheld and bodypack transmitters.

- i** For information about installation and operation, see the instruction manual: [The CHG 2 charger](#)



The CHG 2N charger



The CHG 2N is a network-compatible charger with two separate charging slots. These ports can be used for the SL Bodypack DW and the SL Handheld DW. The four LEDs on each charging slot indicate the current charging status. The versatile network interface is compatible with IPv4 and IPv6 for seamless integration. The Sennheiser Control Cockpit software can be used to monitor and remotely control the settings and status messages.

- i** For information about installation and operation, see the instruction manual: [The CHG 2N charger](#)



The CHG 4N charger



The CHG 4N is a network-compatible charger with four separate charging slots. These ports can be used for the SL Bodypack DW and the SL Handheld DW. The four LEDs on each charging slot indicate the current charging status. The versatile network interface is compatible with IPv4 and IPv6 for seamless integration. The Sennheiser Control Cockpit software can be used to monitor and remotely control the settings and status messages.

- i** For information about installation and operation, see the instruction manual: [The CHG 4N charger](#)



The CHG 2W charging base



The CHG 2W is a wireless charging base that provides convenient wireless charging.

The CHG 2W charging base is compatible with the SL Tablestand 133-S DW, the SL Tablestand 153-S DW and the SL Boundary 114-S DW.

i For information about installation and operation, see the instruction manual: [The CHG 2W charging base](#)



Accessories

Various accessory parts are available for the SpeechLine Digital Wireless series.

The clip-on and headset microphones



The MKE 1 clip-on microphone is attached to clothing by means of a microphone clip or with adhesive tape, the Headmic 1 headset microphone is a head-worn microphone with an adjustable frame that wraps around the neck. The unobtrusive design of the microphones lets the audience focus on the speaker. The microphones are connected to the bodypack transmitter and thus offer the speaker complete freedom of movement.

i For information about installation and operation, see the instruction manual: [The Headmic 1 headset microphone](#) and [The MKE 1 clip-on microphone](#)



GA 4 mounting kit

You need the GA 4 mounting kit to install the receiver in a rack (see [Installing receivers in a rack](#)). The GA 4 mounting kit is available separately as an accessory and is also supplied with the following sets:

- SL Handheld-Set R
- SL Headmic-Set R
- SL Lavalier-Set R

The GA 4 mounting kit consists of:

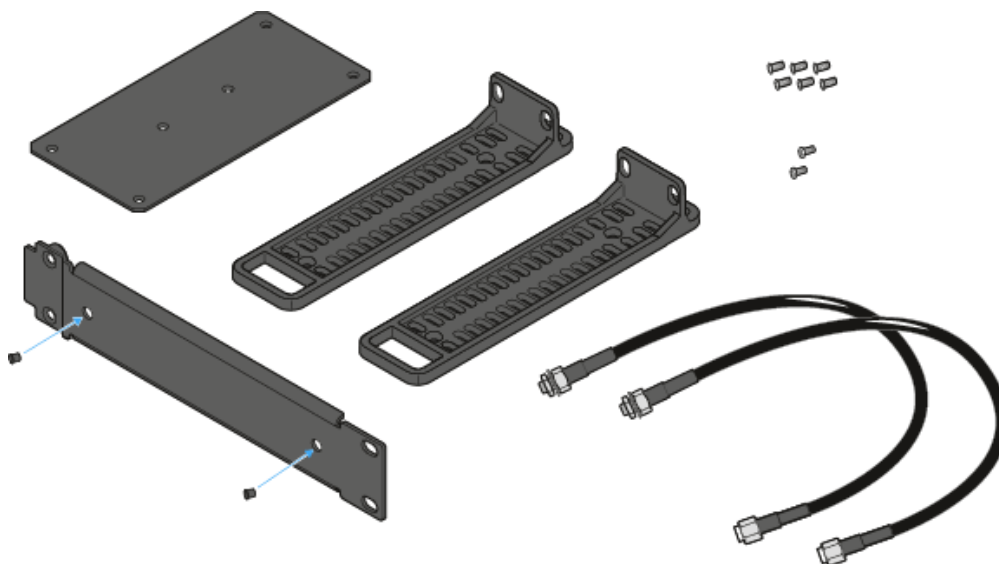



The AWM 2 antenna wall mount

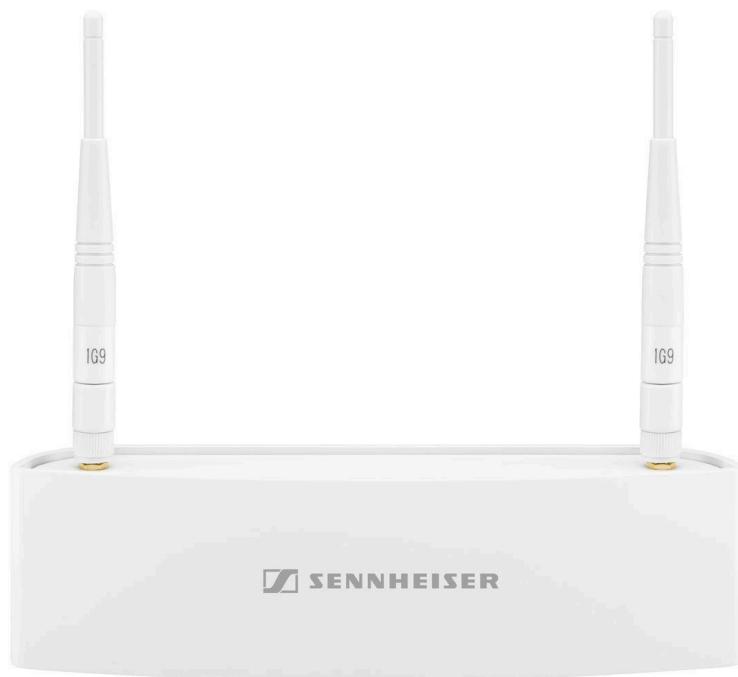

With the AWM 2 antenna wall mount, the antenna can be remote mounted – optimally positioned and nearly invisible – from the receiver (e.g. when the receiver has to be installed invisibly or when the receiver position is not the best antenna position for optimum reception). The AWM 2 can be easily mounted on a microphone stand or permanently installed on a wall.

i For information about installation and operation, see the instruction manual: [AWM 2 / AWM 4 remote antennas](#)



The AWM 4 antenna wall mount

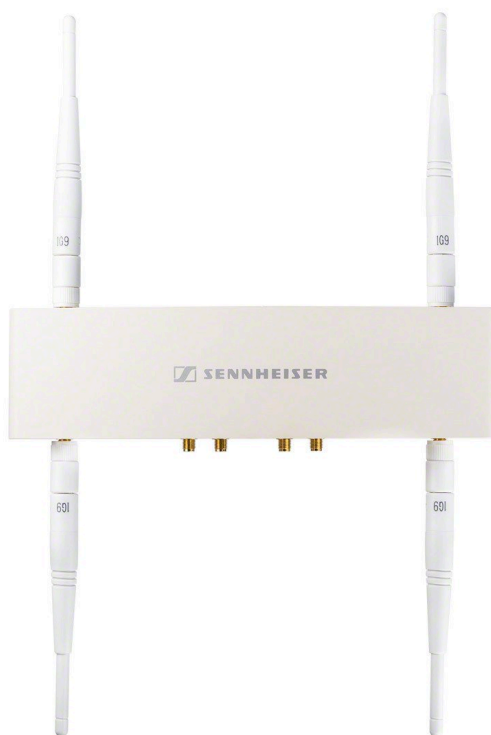

With the AWM 4 antenna wall mount, the antenna can be remote mounted – optimally positioned and nearly invisible – from the receivers (e.g. when the receivers have to be installed invisibly or when the receiver position is not the best antenna position for optimum reception). The AWM 4 can be easily mounted on a microphone stand or permanently installed on a wall.

i For information about installation and operation, see the instruction manual: [AWM 2 / AWM 4 remote antennas](#)



The SL PASC 2 passive antenna splitter



The SL PASC 2 is a passive two-way true diversity antenna splitter/combiner for the SpeechLine Digital Wireless microphone series. It is used to distribute the antenna signals from up to 2 SpeechLine Digital Wireless radio links. In combination with the AWM 2 or AWM 4 remote antennas, the number of required antenna cables is reduced to a minimum. The rack receivers are connected to the SL PASC 2 using the supplied SMA-R cables.

- i** For information about installation and operation, see the instruction manual: [The SL PASC 2 passive antenna splitter/combiner](#)



The SL PASC 4 passive antenna splitter



The SL PASC 4 is a passive four-way true diversity antenna splitter/combiner for the SpeechLine Digital Wireless microphone series. It is used to distribute the antenna signals from up to 4 SpeechLine Digital Wireless radio links. In combination with the AWM 2 or AWM 4 remote antennas, the number of required antenna cables is reduced to a minimum. The rack receivers are connected to the SL PASC 4 using the supplied SMA-R cables.

- i** For information about installation and operation, see the instruction manual: [The SL PASC 4 passive antenna splitter/combiner](#)



Antenna cables

- **CL 1 PP**, R-SMA antenna cable for AWM 2/4, 1 m, article no. 507425
- **CL 5 PP**, R-SMA antenna cable for AWM 2/4, 5 m, article no. 507426
- **CL 10 PP**, R-SMA antenna cable for AWM 2/4, 10 m, article no. 507427
- **CL 20 PP**, R-SMA antenna cable for AWM 2/4, 20 m, article no. 507428



3. System planning

This section of the documentation contains information to help you with system planning.

- Planning Preparation: important information about country-specific frequency variants, correct use of transmission power and recommendations for space usage. -> [Planning](#)
- Using Antennas: important information that you need to take into account when installing and using antennas. -> [Recommendations on antenna mounting](#)
- Multi-Room Mode: important information if you intend to use SpeechLine Digital Wireless in multiple rooms within one building. -> [Multi-room mode](#)

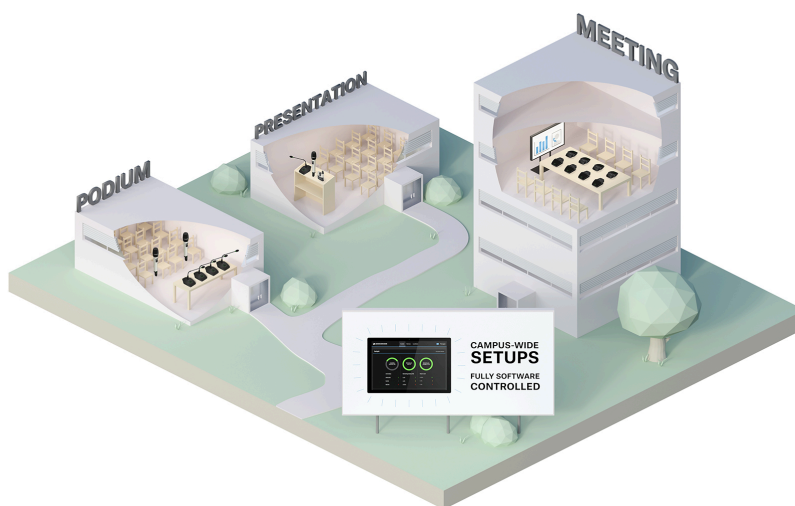

When planning the installation of a wireless audio system, there are some aspects to be considered such as the number and size of the rooms to be equipped or the number of the wireless microphone links you plan to install.

These aspects are crucial for any project regardless of size. In this part of the documentation, we would like to offer some advice on how to proceed when planning a SpeechLine Digital Wireless installation.

i **Planning Tool**

To make planning even easier, we offer a planning tool available on the SpeechLine Digital Wireless product page:

sennheiser.com/speechline-wireless

Planning

At the start of planning, the following aspects are to be considered.



Country-Specific Variants

Check which country variant of SpeechLine Digital Wireless is suitable for your location. The following eight country variants are available.

The country variant to be used determines the maximum number of links per range which can be used in the 1.9 GHz frequency band.

Variante -3:

Main countries and regions:

- Europe
- UK
- Hong Kong
- Singapore
- Malaysia
- Australia

Frequency range:

- 1,880 - 1,900 MHz

Available power supply units:

- EU
- UK
- AU

Wireless links per reception range:

- up to 20

Variante -4:

Main countries and regions:

- USA
- Canada
- Latin America (without Brazil)

Frequency range:

- 1,920 - 1,930 MHz

Available power supply units:

- EU
- US



Wireless links per reception range:

- up to 10

Variante -5:

Main countries and regions:

- Japan

Frequency range:

- 1,893 - 1,906 MHz

Available power supply units:

- US

Wireless links per reception range:

- up to 4

Variante -6:

Main countries and regions:

- Taiwan

Frequency range:

- 1,880 - 1,895 MHz

Available power supply units:

- US

Wireless links per reception range:

- up to 12

Variante -7:

Main countries and regions:

- Brasilien

Frequency range:

- 1,910 - 1,920 MHz



Available power supply units:

- EU

Wireless links per reception range:

- up to 12



Number and size of the rooms

- ▶ Determine the number of rooms needed for the installation.
- ▶ Determine how each individual room is to be equipped and used.
- ▶ Determine the audio equipment for each room, i.e. the desired number of SpeechLine Digital Wireless links.
- ▶ Check if there are other devices (e.g. DECT devices) using the 1.9 GHz frequency band.
- ▶ Double-check that the number of 1.9 GHz devices used on-site does not exceed the available spectrum (see [Shared use of the 1.9 GHz frequency band](#)).



Shared use of the 1.9 GHz frequency band

When SpeechLine Digital Wireless is used in combination with other devices using the 1.9 GHz frequency band (e.g. Sennheiser TeamConnect Wireless or DECT telephones), the maximum number of SpeechLine Digital Wireless links depends on the number of other devices used.

The following charts indicate the possible combinations of systems depending on country-specific conditions (see also [Country-Specific Variants](#)).

Europe, UK, Hong Kong, Singapore, Malaysia, Australia

SpeechLine Digital Wireless Links - per range (adjustable)

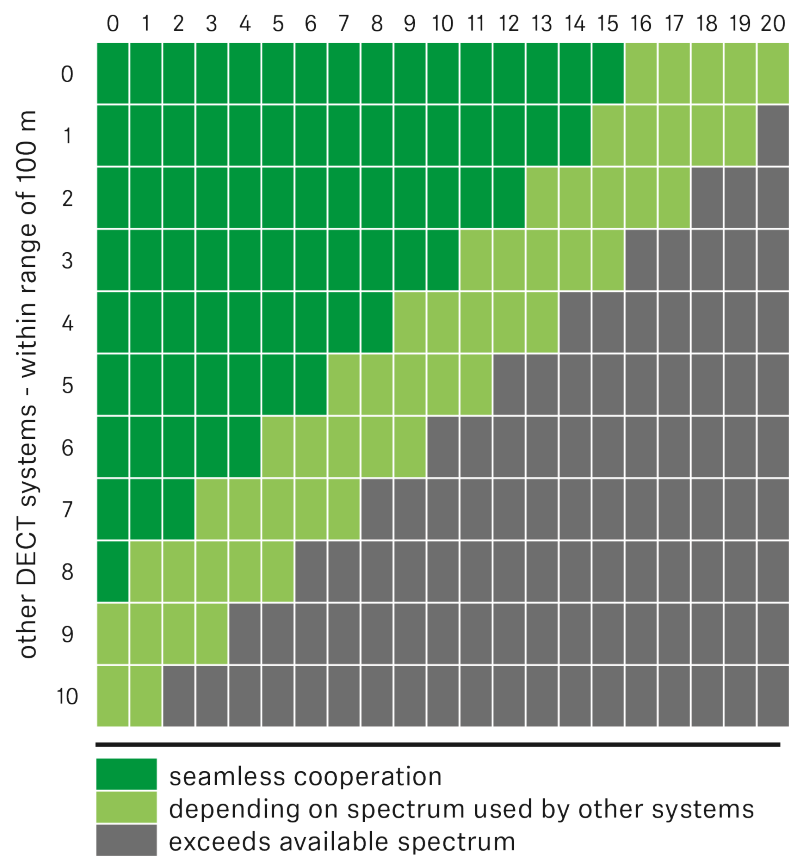



USA, Canada, Latin America, Brazil, Taiwan

SpeechLine Digital Wireless Links -
per range (adjustable)

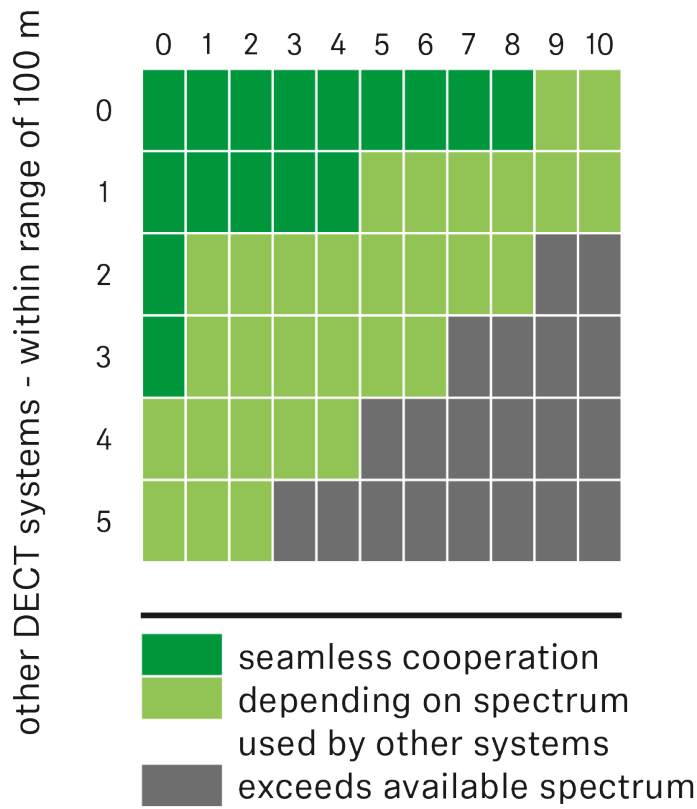



Japan

SpeechLine Digital Wireless Links -
per range (adjustable)

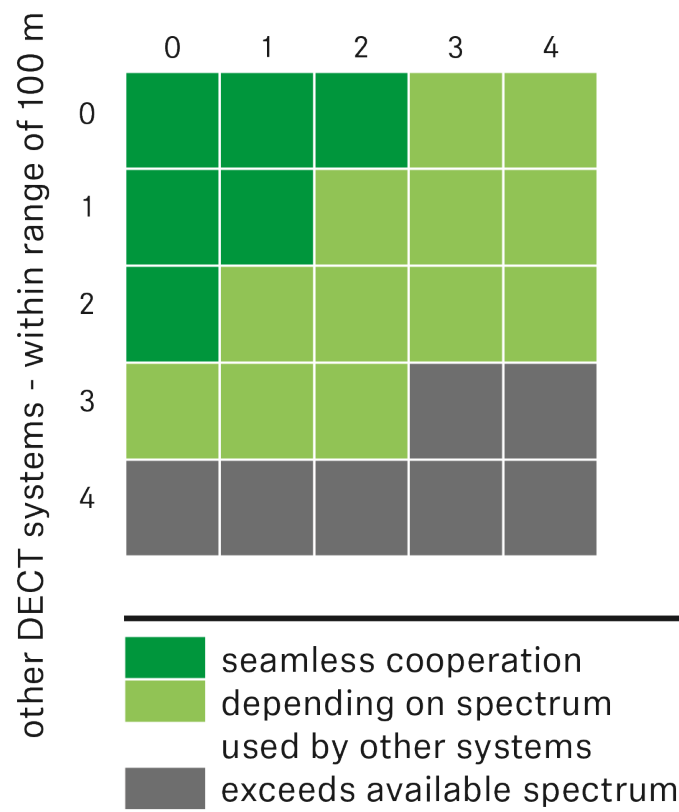



Analysis of the environmental conditions

When planning the installation of a SpeechLine Digital Wireless system, you should also carefully analyze the environmental conditions. Are there any other 1.9 GHz devices (e.g. DECT telephones or DECT access points) already installed?

Observe the following aspects when planning an installation

- ▶ Identify the locations of DECT access points (e.g. for DECT telephone systems). Also observe the information provided under [Shared use of the 1.9 GHz frequency band](#).
- ▶ Determine the type of installation, i.e. where and how the microphone receivers are to be installed.
- ▶ Determine whether the antenna are to be mounted remotely from the receivers. When remote mounting the antenna, also take into account possible losses due to long cable runs. Also see [Recommendations on antenna mounting](#).
- ▶ When installing remote antenna, observe a minimum distance of 3 m to the next DECT access point.
- ▶ To make network control very simple, we recommend using a network switch to connect the receivers in the network.



Recommendations on antenna mounting

There are different factors to consider when mounting antennas. This chapter provides instructions and recommendations that you should follow when mounting antenna.

Antenna setup and planning for SpeechLine Digital Wireless

When planning the installation of SpeechLine Digital Wireless devices for each room, observe the following guidelines.

- ▶ Mount all SpeechLine Digital Wireless receivers together in one rack.
- ▶ Make sure to have a direct line of sight between the transmitters and the receiving antennas.
- ▶ Depending on the room characteristics there are several options how to install the receiving antennas. We recommend the following options in this order:
 - Option 1: remotely mounted using the AWM 2 for one receiver or the AWM 4 for two receivers. [Option 1: Connecting the AWM 2 or AWM 4 antenna wall mount directly to the receiver\(s\)](#)
 - Option 2: remotely mounted using the AWM 2 or AWM 4 and multiple receivers combined using an antenna splitter (passive splitters SL PASC 2 or SL PASC 4). [Option 2: Combining multiple links to one AWM 2/AWM 4](#)
 - Option 3: mounted in a rack (front) [Option 3: Rack mounting - front](#)
 - Option 4: mounted in a rack (rear). [Option 4: Rack mounting - rear](#)
- ▶ When mounting antennas remotely, observe the minimum distance to possibly existing DECT access points and also take into account the cable lengths.
- ▶ Always switch all receivers on and off with a common power supply (e.g. a multi-outlet power strip with a central on/off switch) in order to achieve the best performance of a system.

i You can find detailed information about the four antenna mounting options under [Antenna mounting options](#).



Antenna mounting options

There are different options for remote mounting the antennas. We recommend the following four options in the specified order.

- [Option 1: Connecting the AWM 2 or AWM 4 antenna wall mount directly to the receiver\(s\)](#)
- [Option 2: Combining multiple links to one AWM 2/AWM 4](#)
- [Option 3: Rack mounting - front](#)
- [Option 4: Rack mounting - rear](#)



Option 1: Connecting the AWM 2 or AWM 4 antenna wall mount directly to the receiver(s)

You can connect one receiver directly to one AWM 2 antenna wall mount or you can connect two receivers directly to one AWM 4 antenna wall mount.

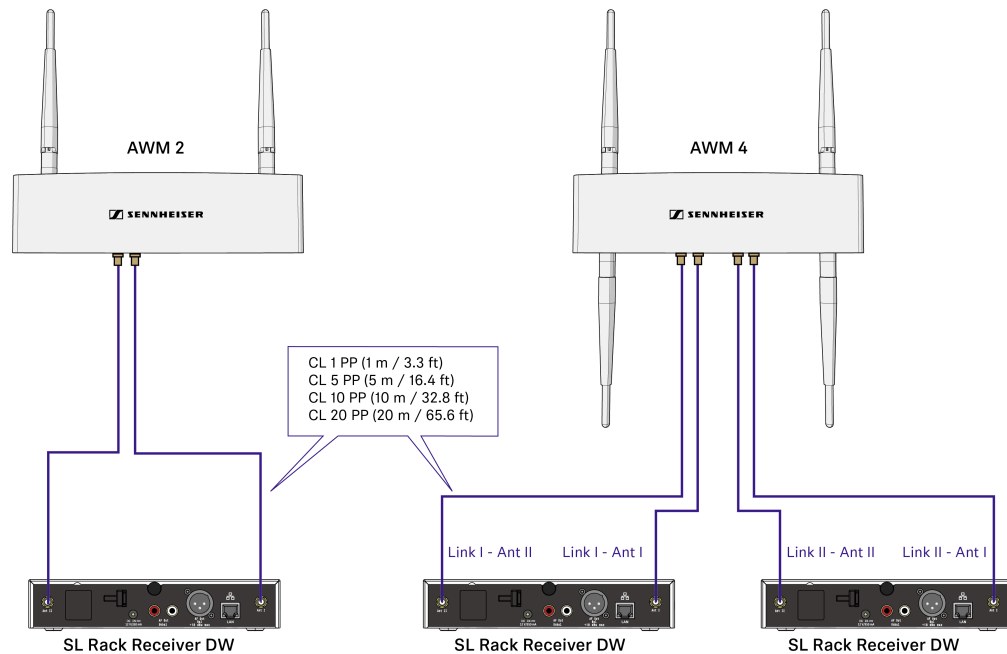

Observe the following information when using extension cables:

Signal loss due to extension cables

In this scenario, using extension cables for remote antenna mounting results in a loss of transmission power, depending on the cable length.

You can compensate this signal loss by configuring the transmission power of the receiver accordingly.

Observe the following minimum transmission power settings (SL Rack Receiver DW: **System Settings menu -> RF Power**) for the respective cable lengths:

- Cable length of 5 m -> at least level 1
- Cable length of 10 m -> selected level +1, at least level 2
- Cable length of 20 m -> selected level +1, at least level 3
- Cable length of 25 m and longer -> selected level +2, at least level 4



Remote antenna distances and line of sight

If you are using multiple antenna wall mounts (AWM 2/AWM 4) in one room or if individual installation and mounting of the antennas is desired, please observe the following aspects:

- Position all antennas as close as possible to each other.
- Make sure that the distances between all antennas are all equal and the same as on the back of the receiver or on the AWM 2 antenna wall mount.

If possible, group the antennas as follows:

- All A antenna from the receivers' ANT I sockets in one group according to the aforementioned requirements
- All B antenna from the receivers' ANT II sockets in one group according to the aforementioned requirements

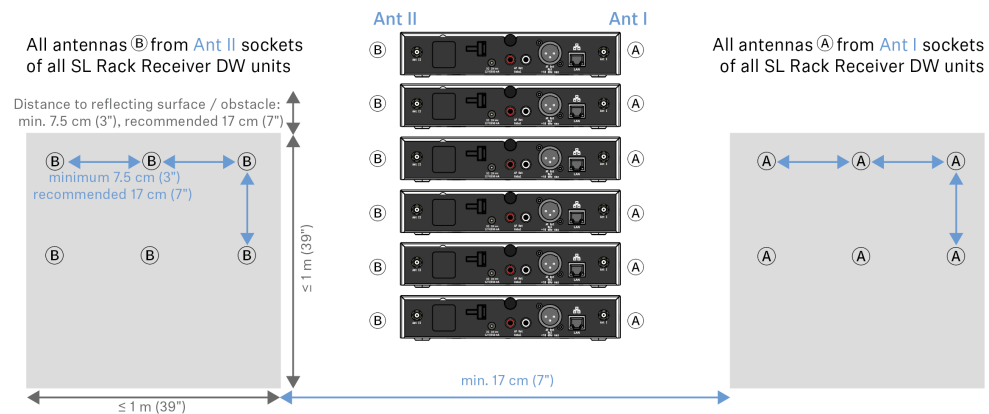

- When using multiple AWM 2/AWM 4 antenna wall mounts, make sure that the distances between all antennas are equal:

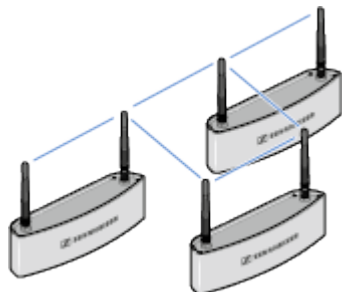

- If possible, position the antennas so that there is a direct line of sight (without obstacles) between the transmitters and the antennas.

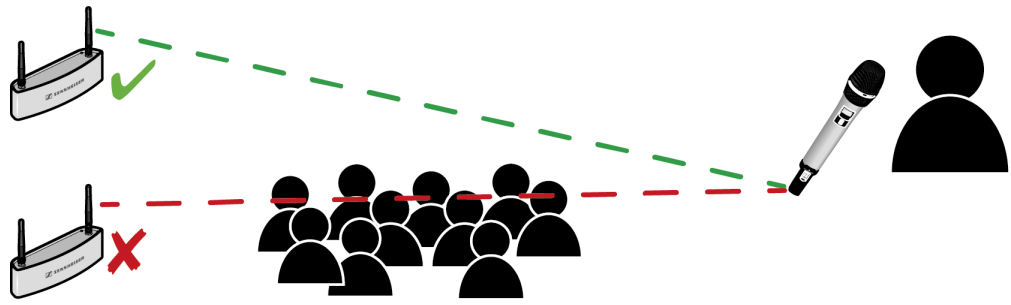



Option 2: Combining multiple links to one AWM 2/AWM 4

With this variant, you can use passive antenna splitters (SL PASC 2 or SL PASC 4) together with the AWM 2 or AWM 4 to combine the antenna signals from multiple receivers. This reduces the number of antenna cables required to a minimum.

Combining up to 2 links using the AWM 2 and the SL PASC 2

The following illustration shows an example of how to combine up to 2 links with one AWM 2 antenna wall mount. This reduces the number of antenna cables required from 4 to 2.

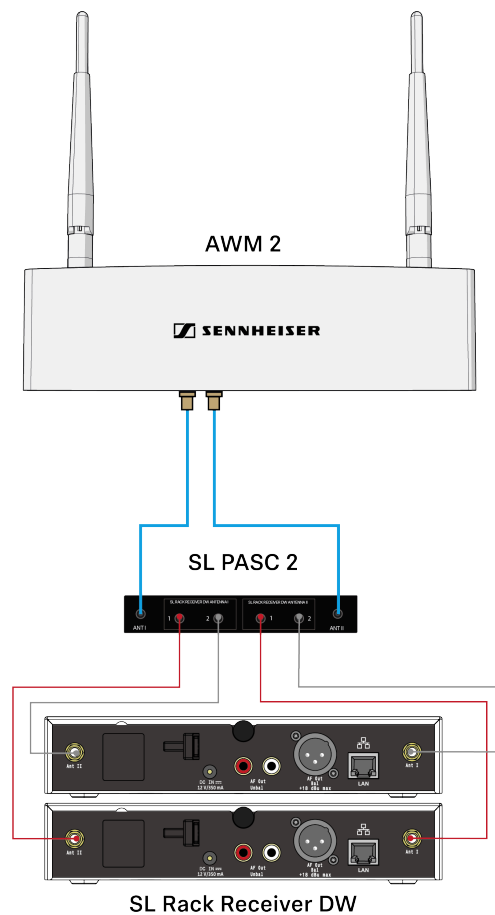

Use the following Sennheiser cables for connecting the AWM 2 to the SL PASC 2:

CL 1 PP (1 m / 3.3 ft)
art. no. 507425

CL 5 PP (5 m / 16.4 ft)
art. no. 507426

CL 10 PP (10 m / 32.8 ft)
art. no. 507427

Cables for connecting the SL PASC 2 to the SL Rack Receiver DW are supplied with the SL PASC 2.

- Please observe the information below on the length of the extension cables ([Signal loss due to extension cables and antenna splitters](#)).

Combining up to 4 links using the AWM 2 and the SL PASC 4

The following illustration shows an example of how to combine up to 4 links with one AWM 2 antenna wall mount. This reduces the number of antenna cables required from 8 to 2.

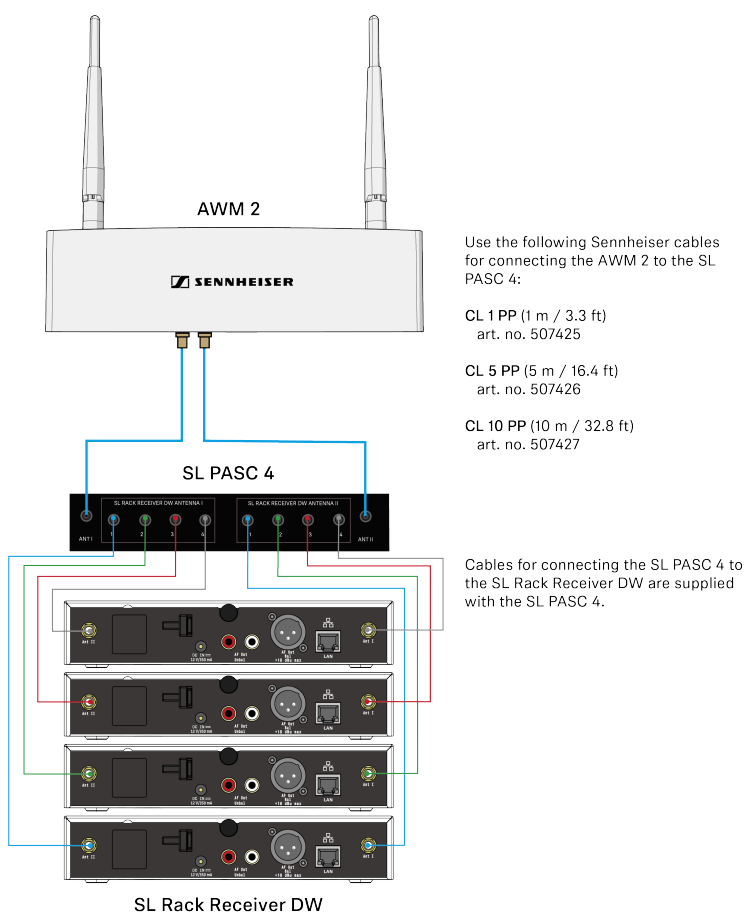

- Please observe the information below on the length of the extension cables ([Signal loss due to extension cables and antenna splitters](#)).

i Always combine all antenna sockets ANT I of all receivers and all antenna sockets ANT II of all receivers respectively to one of the two antennas of the AWM 2. If you are using only 3 of the 4 connections on the antenna splitter, you should close the unused connection with a terminating resistor (50 Ω) to minimize interfering signals and maximize transmission power.

Combining up to 8 links using the AWM 4 and two SL PASC 4 units

The following illustration shows an example of how to combine up to 8 links with one AWM 4 antenna wall mount. This reduces the number of antenna cables required from 16 to 4.

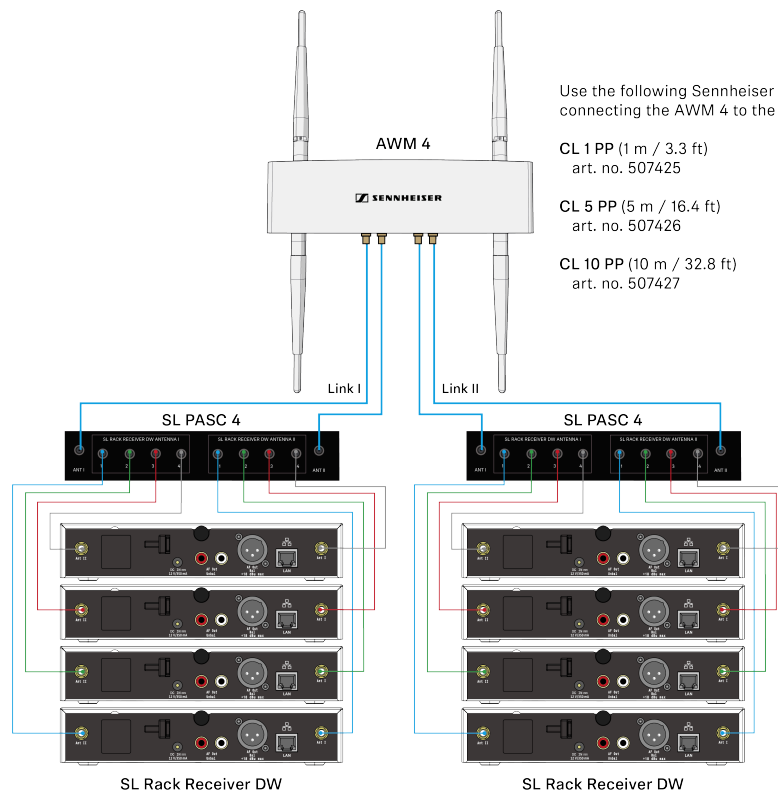

Use the following Sennheiser cables for connecting the AWM 4 to the SL PASC 4:

CL 1 PP (1 m / 3.3 ft)
art. no. 507425

CL 5 PP (5 m / 16.4 ft)
art. no. 507426

CL 10 PP (10 m / 32.8 ft)
art. no. 507427

Cables for connecting the SL PASC 4 to the SL Rack Receiver DW are supplied with the SL PASC 4.

- Please observe the information below on the length of the extension cables ([Signal loss due to extension cables and antenna splitters](#)).

i Always combine all antenna sockets ANT I of up to four receivers and all antenna sockets ANT II of up to four receivers respectively to the two sockets of one link of the AWM 4. If you are not using all connections on the antenna splitter, you should close the unused connections with a terminating resistor (50 Ω) to minimize interfering signals and maximize transmission power.

Signal loss due to extension cables and antenna splitters

In this scenario, the use of extension cables and antenna splitters with a remotely mounted antenna may result in loss of transmission power, depending on the cable length.

You can compensate this signal loss by configuring the transmission power of the receiver accordingly. Observe the following minimum transmission power settings (SL Rack Receiver DW: **System Settings menu** -> **RF Power**) for the respective cable lengths. The antenna splitter causes about as much signal loss as a cable length of 15 m. These losses must be included in the calculation of the transmission power level.



We **recommend** the following **cable lengths** in combination with the antenna splitter:

- Receiver to splitter: 1 m -> splitter to AWM 2/4: 1 m
- Receiver to splitter: 1 m -> splitter to AWM 2/4: 5 m
- Receiver to splitter: 1 m -> splitter to AWM 2/4: 10 m
- Receiver to splitter: 5 m -> splitter to AWM 2/4: 1 m
- Receiver to splitter: 5 m -> splitter to AWM 2/4: 5 m
- Receiver to splitter: 10 m -> splitter to AWM 2/4: 1 m

i Cables longer than 10 m are not recommended for this variant.

This results in the following transmission power levels to be set in the menu of the receiver or simultaneously for all receivers in the Sennheiser Control Cockpit software:

- 5 m cable length plus splitter -> at least level 2
- 10 m cable length plus splitter -> at least level 3

Direct line of sight

- If possible, position the antennas so that there is a direct line of sight (without obstacles) between the transmitters and the antennas.

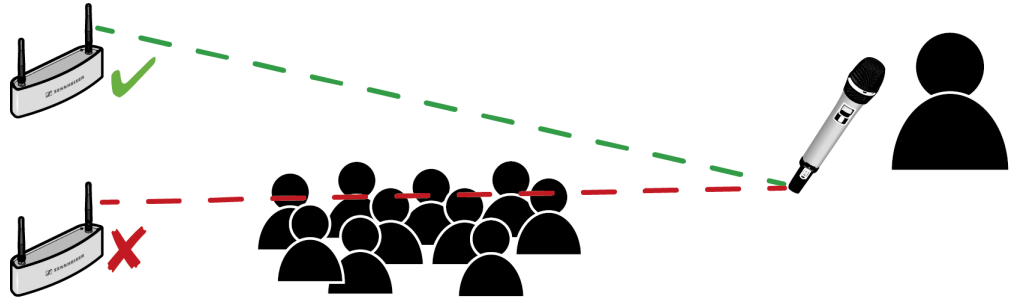



Option 3: Rack mounting - front

If you wish to install the antenna together with the receivers in a rack, we recommend mounting the antenna on the front side of the rack using the GA 4 mounting kit.

- ▶ Always leave 1 U of space between receivers and antenna.
- ▶ Position the antennas at an angle of about 45°.

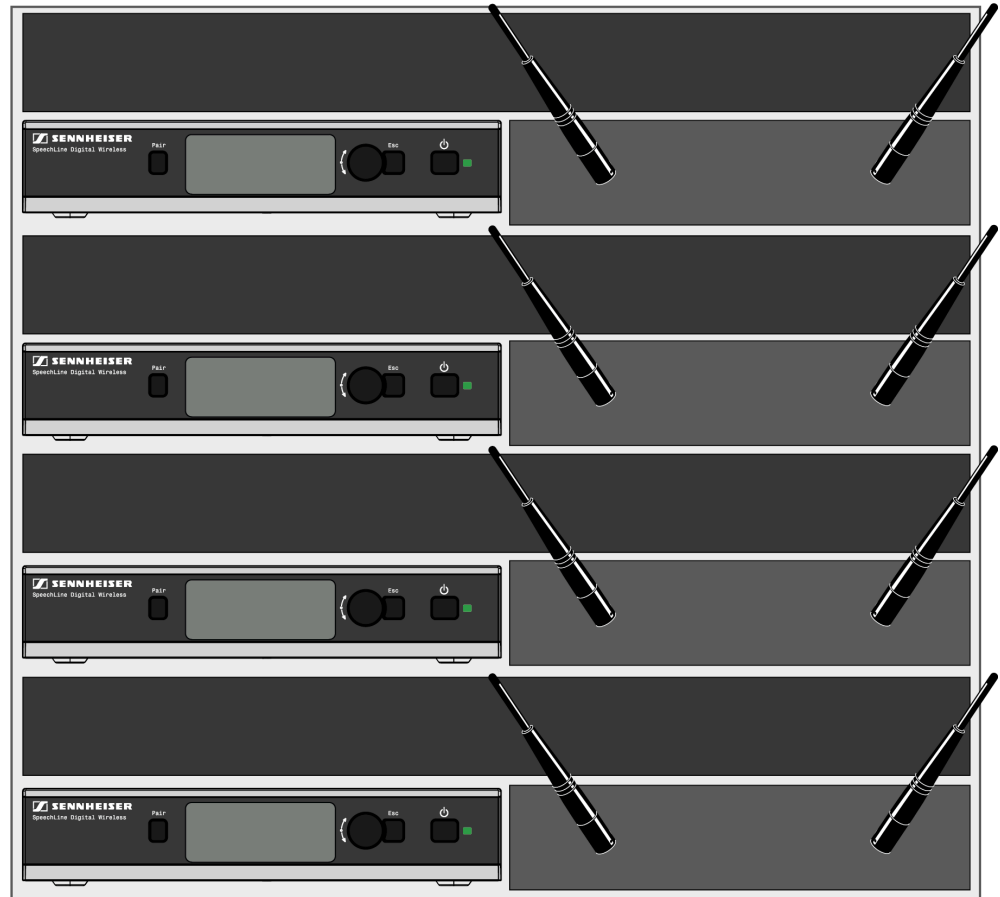



Option 4: Rack mounting - rear

If you cannot mount the antennas at the front of the rack (option 3), you can also mount them at the rear of the receiver in the rack. When mounting, observe the following information.

- ▶ Position the antennas so that they point at a 180-degree angle away from the receiver.
- ▶ Run all cables close to the receivers to prevent the cables from interfering with the antenna reception. Use the cable grip.
- ▶ For best system performance, make sure that the antennas are not covered or shielded by blocking obstacles such as cables, metal plates, or cases.
- ▶ In this case, and if possible, make sure that there is a direct line of sight between the transmitters and the receivers for best possible RF performance.

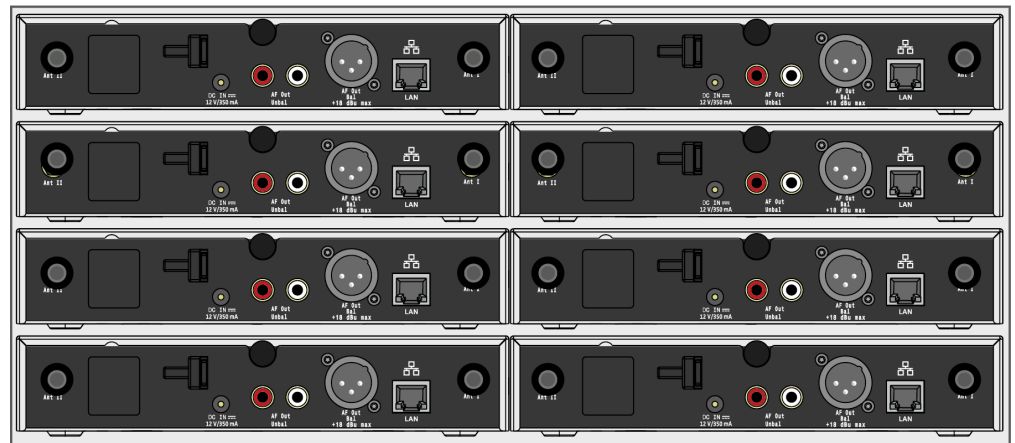



Further important information on antenna usage

Reflecting surfaces

Electrically conducting surfaces (e.g. ceilings with metal constructions) can reflect the RF signal.

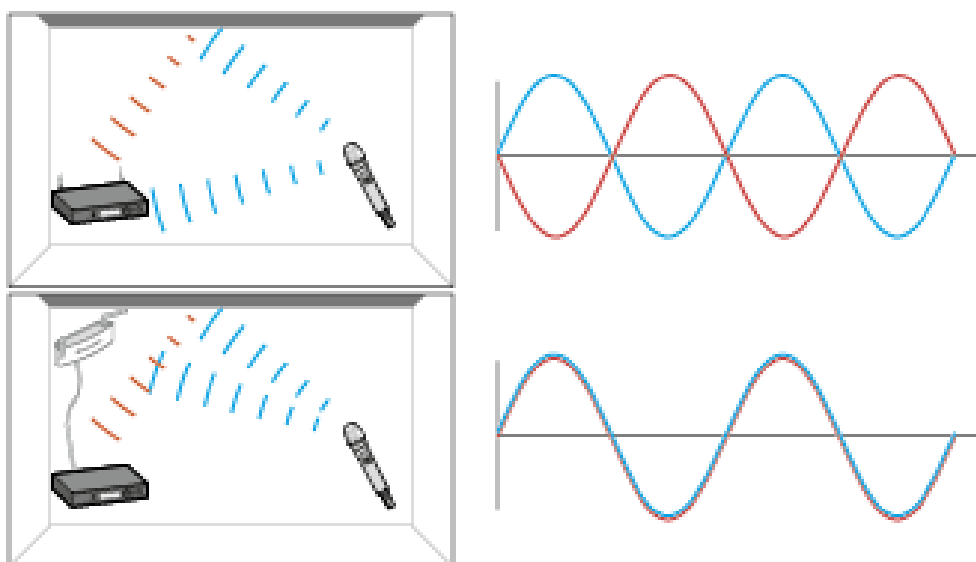

The signal is reflected by the electrically conducting surface. At worst, the blue signal and the red reflected signal are out of phase when they reach the receiver so that the two signals cancel each other out.

- ▶ If you have electrically conducting surfaces in a room, make sure to position the receiver or the antenna wall mounts so that such reflection effects are avoided.
- ✓ If you have a reflecting ceiling, this can be achieved by positioning the antenna closer to the ceiling.

Blocking effects from other transmitters

i As with all wireless microphone systems, suboptimal positioning of transmitters can lead to blocking effects. To avoid this, please follow these recommendations:

- ▶ Position DECT telephone or DECT access points at least 7 m from the antenna.
- ▶ Position other wireless devices such as mobile phones at least 1 to 2 m from the antenna.
- ▶ When transmitters are currently in use, **you must not position any other transmitters in the blocking area.** If you must position them there, switch them off.



Rule of thumb for distance from the blocking area:

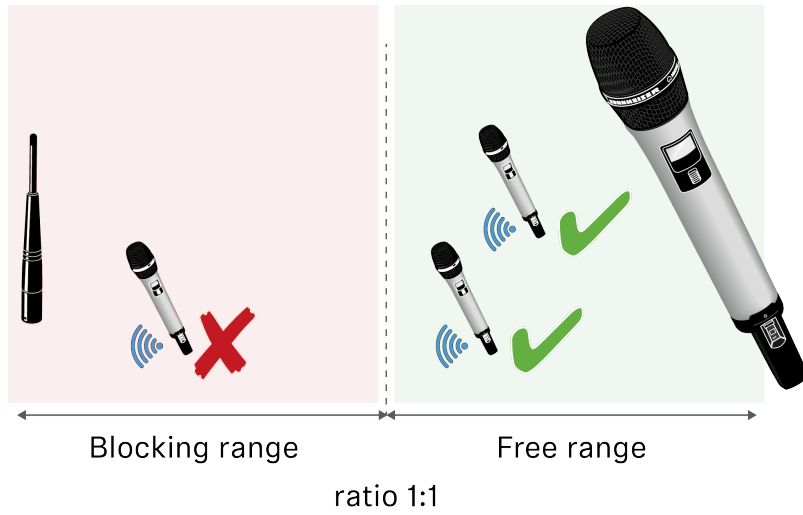

Example:

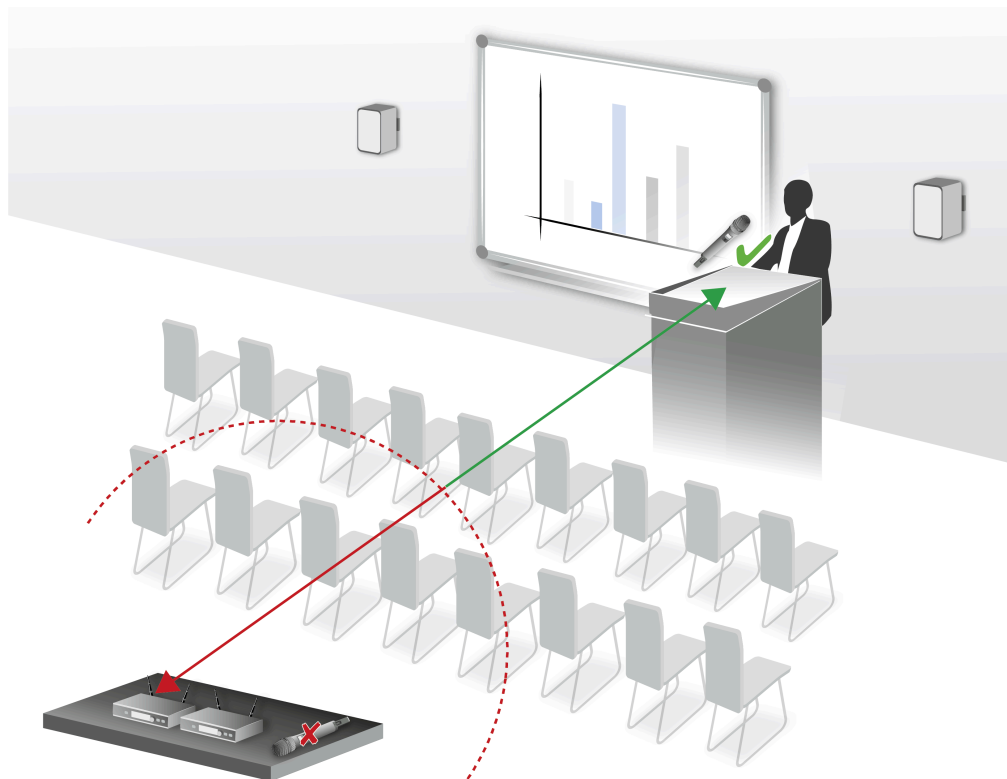



Multi-room mode

SpeechLine Digital Wireless, by taking into account the installation size as well as country-specific regulations, allows to optimally use the 1.9 GHz frequency band.

SpeechLine Digital Wireless offers two operating modes for different types of installation: the **automatic mode** with adaptive transmission power for single-room installations (**Adaptive Power Mode**) and the **manual mode** for multi-room installations, which is known as **Multi-Room Mode**.

For up to 20* links used in parallel, the Adaptive Power Mode ensures extremely easy startup and a reliable maximum range.

The **Multi-Room Mode** allows you to adjust the transmission power to allow for a considerably larger number of links.

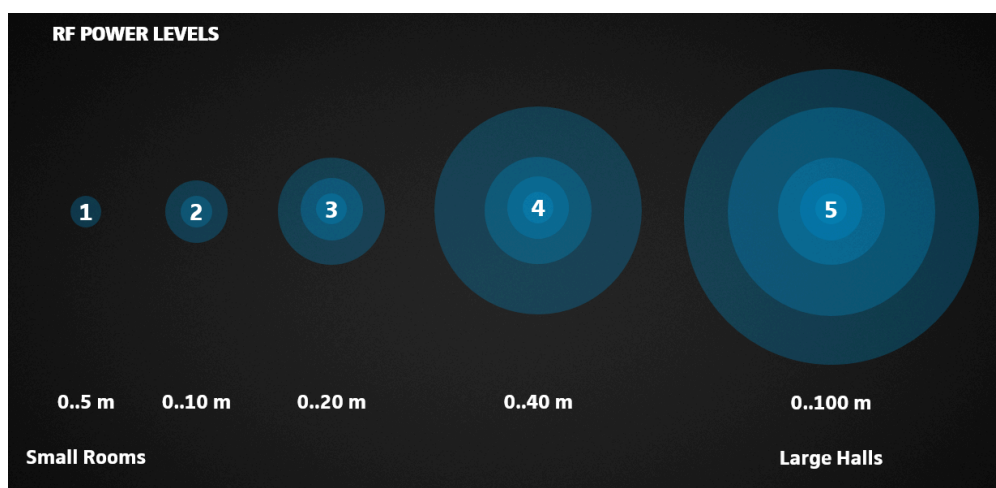

These adjustment options make SpeechLine Digital Wireless the optimum solution for a great variety of projects with widely differing installation sizes at the same location.

* depending on the locally approved variant (see [Country-Specific Variants](#)).

When installing and starting up SpeechLine Digital Wireless systems in projects of different sizes, observe the following steps.

Single-room setup with SL Rack Receiver DW only

- ▶ Install all receivers in one rack (see [Installing receivers in a rack](#)).
- ▶ Connect all cables for the receivers (see [Connecting the receiver](#)).
- ▶ Mount all antennas as recommended and feasible (see [Recommendations on antenna mounting](#)).
- ▶ Ensure that all receivers are switched off.
- ▶ Switch on the first receiver. This receiver will become the Master.
- ▶ If necessary, pair a transmitter. Only if necessary, as the sets are delivered already paired.
- ▶ Wait until both the LED of the receiver and the LED of the transmitter light up green.



- ▶ Perform a walk test to ensure the best reception coverage (see [Performing a walk test \(reception quality\)](#)).
- ▶ Switch on all other receivers. They will synchronize with the Master. Make sure to leave the Master receiver switched on during this step.



Single-room setup with SL Multi-Channel Receiver DW only

- ▶ Install the SL Multi-Channel Receiver DW on a wall or the ceiling with the front side of the receiver facing into the room (see [Mounting the receiver](#)).
- ▶ Connect a LAN cable supplying PoE to the **Dante I / PoE / Ctrl RJ-45** socket of the first SL Multi-Channel Receiver DW (see [Connecting the receiver](#)).
 - ✓ This receiver will become the Master.
- ▶ Wait until the LEDs of the receiver light up red.
- ▶ Connect a LAN cable supplying PoE to the respective **Dante I / PoE / Ctrl RJ-45** sockets of all other SL Multi-Channel Receiver DW units (see [Connecting the receiver](#)).
 - ✓ They will synchronize with the Master.

i When you are using multiple SL Multi-Channel Receiver DW units, it is possible to daisy-chain the network and audio signals by using the “Single-Cable Mode” (factory default setting, see [Connecting the receiver](#)). PoE will not be daisy-chained, so a PoE injector is required for any additional SL Multi-Channel Receiver DW.



Single-room setup with both SL Rack Receiver DW and SL Multi-Channel Receiver DW

- ▶ Install the SL Multi-Channel Receiver DW on a wall or the ceiling with the front side of the receiver facing into the room (see [Mounting the receiver](#)).
- ▶ Install the SL Multi-Channel Receiver DW to a wall or the ceiling with the front side of the receiver facing into the room (see [Installing receivers in a rack](#) and [Connecting the receiver](#)).
- ▶ Mount all antennas for the rack receivers as recommended and feasible (see [Recommendations on antenna mounting](#)).
- ▶ Connect a LAN cable supplying PoE to the **Dante I / PoE / Ctrl RJ-45** socket of the first SL Multi-Channel Receiver DW (see [Connecting the receiver](#)).
 - ✔ This receiver will become the Master.
- ▶ Wait until the LEDs of the receiver light up red.
- ▶ Connect a LAN cable supplying PoE to the **Dante I / PoE / Ctrl RJ-45** sockets of all other SL Multi-Channel Receiver DW units (see [Connecting the receiver](#)).
- ▶ Schalten Sie alle Rack-Empfänger ein.
 - ✔ They will synchronize with the Master.

i When you are using multiple SL Multi-Channel Receiver DW units, it is possible to daisy-chain the network and audio signals by using the “Single-Cable Mode” (factory default setting, see [Connecting the receiver](#)). PoE will not be daisy-chained, so a PoE injector is required for any additional SL Multi-Channel Receiver DW.



Multi-Room Mode setup with SL Rack Receiver DW only

When installing SpeechLine Digital Wireless in several rooms, it is crucial that you perform the following steps one after the other and room by room. When installing SpeechLine Digital Wireless devices in one room, all devices in all other rooms must be switched off.

- ▶ Install all receivers in a room in one rack (see [Installing receivers in a rack](#)).
- ▶ Connect all cables for the receivers (see [Connecting the receiver](#)).
- ▶ Make sure to power all receivers via a multiple socket with a central power switch.
- ▶ Mount all antennas as recommended and feasible (see [Recommendations on antenna mounting](#)).
- ▶ Ensure that all receivers are switched off.
- ▶ Switch on the first receiver. This receiver will become the Master.
- ▶ If necessary, pair a transmitter. Only if necessary, as the sets are delivered already paired.
- ▶ Set the RF power of the receiver to the recommended RF power level according to the room size as indicated on the receiver UI or in the Sennheiser Control Cockpit.
- ▶ Power cycle (switch off and on again) the receiver to verify the selected value.
- ▶ Perform a walk test to ensure the best reception coverage (see [Performing a walk test \(reception quality\)](#)).
- ▶ If necessary adjust the RF power level and repeat the walktest for verification.
- ▶ Make sure to leave the Master receiver switched on for all following steps.
- ▶ Then, switch on all other receivers. They will synchronize with the Master.
- ▶ Set all other receivers to the same RF power level as the Master receiver.
- ▶ Power cycle the other receivers. The Master receiver must be switched on all the time.
- ▶ Once the rack is configured, all devices must be switched off/on together every time via the central power switch of the multiple socket.
- ▶ Make sure not to switch any receiver on or off individually.



Multi-Room Mode setup with SL Multi-Channel Receiver DW only

When installing SpeechLine Digital Wireless in several rooms, it is crucial that you perform the following steps one after the other and room by room. When installing SpeechLine Digital Wireless devices in one room, all devices in all other rooms must be switched off.

- ▶ Install all SL Multi-Channel Receiver DW units of one room to a wall or the ceiling with the front sides of the receivers facing into the room.

i Note: to ensure the Master/Follower functionality the receivers should be installed side to side and not back to back, as indicated in the following illustration.

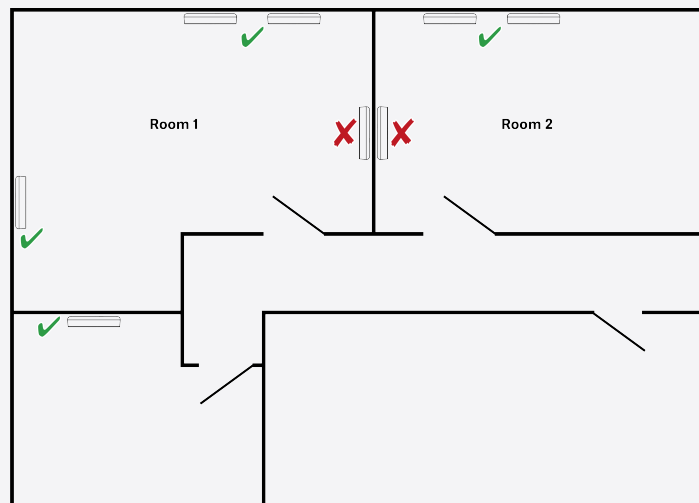

- ▶ Connect a LAN cable supplying PoE to the **Dante I / PoE / Ctrl RJ-45** socket of the first SL Multi-Channel Receiver DW (see [Connecting the receiver](#)).
 - ✓ This receiver will become the Master.
- ▶ Pair all transmitters.
- ▶ Set the RF power level of the receiver to the recommended RF power level according to the room size as indicated in the Sennheiser Control Cockpit.
- ▶ Perform a walk test to ensure the best reception coverage.
- ▶ If necessary adjust the RF power level and repeat the walktest for verification.
- ▶ Connect a LAN cable supplying PoE to the **Dante I / PoE / Ctrl RJ-45** sockets of all other SL Multi-Channel Receiver DW units of the room (see [Connecting the receiver](#)).
 - ✓ They will synchronize with the Master.



- ▶ Set all other receivers to the same RF power level as the Master receiver.
- ▶ Switch off all devices in this room before setting up the devices in the next room.



Multi-Room Mode setup with both SL Rack Receiver DW and SL Multi-Channel Receiver DW

When installing SpeechLine Digital Wireless in several rooms, it is crucial that you perform the following steps one after the other and room by room. When installing SpeechLine Digital Wireless devices in one room, all devices in all other rooms must be switched off.

- ▶ Install all SL Multi-Channel Receiver DW units of one room to a wall or the ceiling with the front sides of the receivers facing into the room.

i Note: to ensure the Master/Follower functionality the receivers should be installed side to side and not back to back, as indicated in the following illustration.

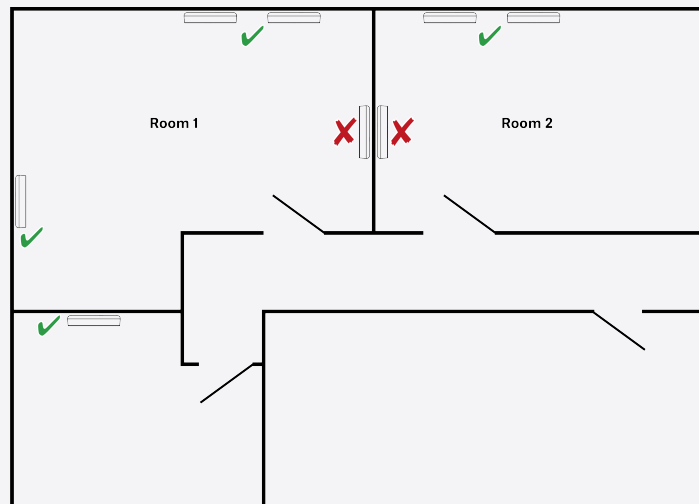

- ▶ Install all SL Rack Receiver DW units in one rack and connect all cables (power, audio and LAN) (see [Installing receivers in a rack](#) and [Connecting the receiver](#)).
- ▶ Mount all antennas for the rack receivers as recommended and feasible (see [Recommendations on antenna mounting](#)).
- ▶ Connect a LAN cable supplying PoE to the **Dante I / PoE / Ctrl RJ-45** socket of the first SL Multi-Channel Receiver DW (see [Connecting the receiver](#)).
- ✔ This receiver will become the Master.
- ▶ Pair all transmitters.
- ▶ Set the RF power level of the receiver to the recommended RF power level according to the room size as indicated in the Sennheiser Control Cockpit.
- ▶ Perform a walk test to ensure the best reception coverage.



- ▶ If necessary adjust the RF power level and repeat the walktest for verification.
- ▶ Connect a LAN cable supplying PoE to the **Dante I / PoE / Ctrl RJ-45** sockets of all other SL Multi-Channel Receiver DW units of the room (see [Connecting the receiver](#)).
- ▶ Set all other multi-channel receivers to the same RF power level as the Master receiver.
- ▶ Then, switch on all SL Rack Receiver DW units.
 - ✔ They will synchronize with the Master receiver.
- ▶ Power cycle (switch off and on again) the rack receivers. The Master receiver must be switched on all the time.
- ▶ Switch off all devices in this room before setting up the devices in the next room.



4. User Manual

This manual provides detailed information about installation and usage of the individual products in the SpeechLine Digital Wireless series.

SL Rack Receiver DW

The 9.5" rack receiver (SL Rack Receiver DW) is the core of the SpeechLine Digital Wireless system. Thanks to the bi-directional communication between the rack receiver and the transmitter, all transmitter settings can be adjusted on the receiver. The receiver's automatic frequency management eliminates the need for manual frequency setting and the automatic interference management guarantees maximum transmission reliability. The user-friendly pairing function ensures a reliable connection between transmitter and receiver. Network integration enables the receiver to be remotely controlled and monitored using a media control system (e.g. AMX, Crestron) or the Sennheiser Control Cockpit software. The antenna can either be mounted to the rear of the receiver or to the front of a rack. Antenna cables of different lengths also allow mounting the antenna remotely from the receiver. The antenna cables are available as accessories.

Product overview and operating elements – front panel

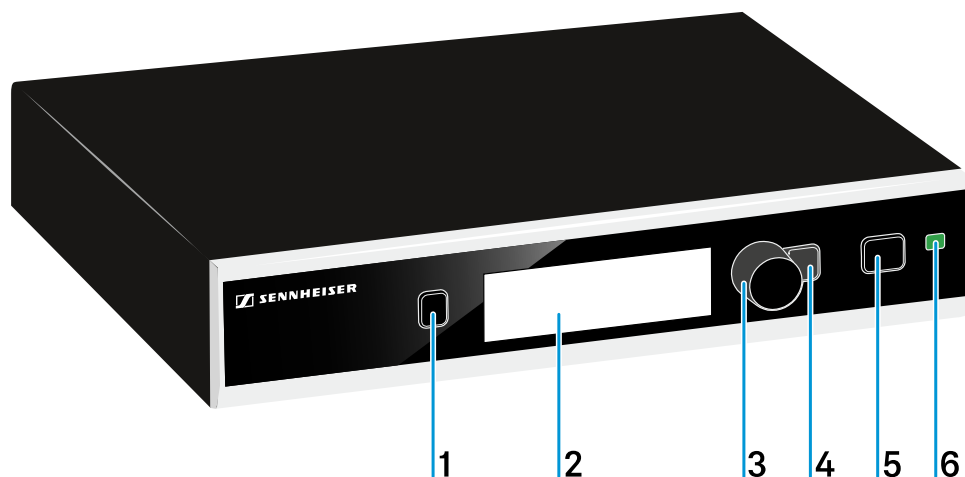

1 PAIR button

Short-press to identify the paired transmitter.

Long-press to pair with a different transmitter.

see [Pairing](#)

2 Display panel

see [Displays on the receiver's display panel](#)



3 Jog dial

Turn to navigate through the menu, to change settings or to change from the home screen to the secondary home screen.

Press to open the menu or to confirm the entry or selection.

4 ESC button

Short-press to navigate to the next higher level in the menu or to exit a menu item without confirming new settings or entries.

Long-press to exit the menu and to return to the home screen.

5 STANDBY button

see [Switching the receiver on and off](#)

6 Status LED

see [Meaning of the Status LED](#)



Product overview and connections – rear panel

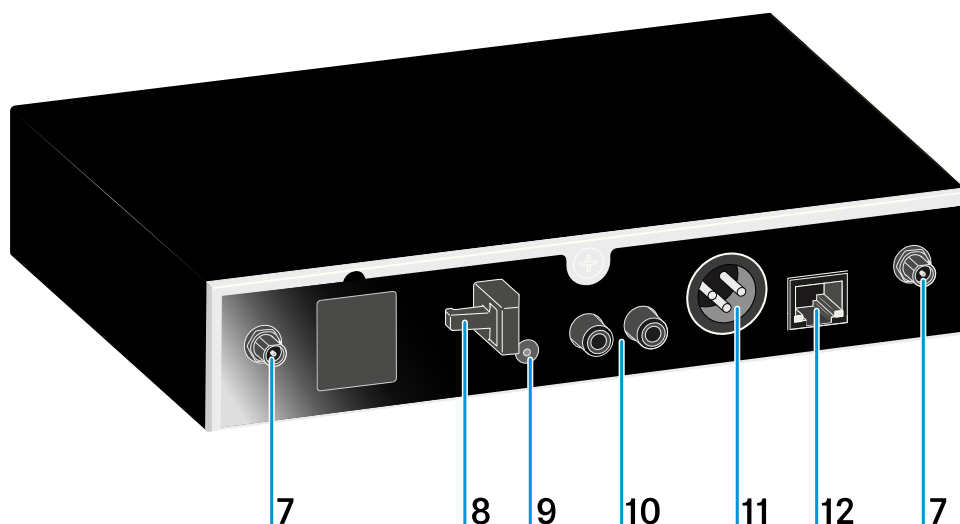

7 ANT I and ANT II antenna sockets (R-SMA)

Antenna inputs for connecting the supplied rod antenna

Alternatively, the antenna can be mounted using extension cables and the AWM 2 antenna wall mount or using the GA 4 mounting kit.

see [GA 4 mounting kit](#) and [AWM 2 / AWM 4 remote antennas](#)

8 Strain relief grip

For the cable of the power supply unit.

see [Connecting the receiver to the power supply system](#)

9 DC IN socket

For the power supply's hollow jack plug.

see [Connecting the receiver to the power supply system](#)

10 AF OUT UNBAL sockets (RCA)

Unbalanced audio output

see [Connecting an amplifier or mixing console to the receiver](#)

11 AF OUT BAL socket (XLR-3)

Balanced audio output (XLR)

see [Connecting an amplifier or mixing console to the receiver](#)

12 LAN Ethernet socket

For connecting to a router or a switch in order to simultaneously control and monitor several devices in the network.

see [Connecting receivers in a network](#)



Meaning of the Status LED

lights up green



A radio link to the transmitter is established. The accupack of the received transmitter is sufficiently charged.

flashes green

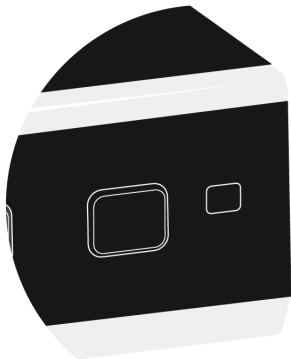

The PAIR button has been short-pressed. Paired devices are being identified.

flashes alternately green and red



The PAIR button has been long-pressed. The receiver establishes a radio link to a transmitter whose PAIR button has also been long-pressed.

lights up yellow

The received transmitter has been muted with the MUTE switch. In addition, **Muted** is displayed on the display panel.

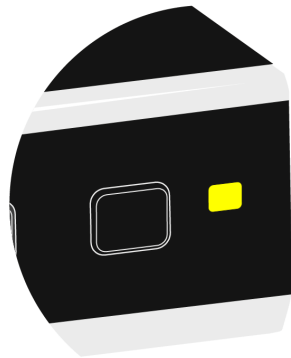

flashes yellow

The firmware is being updated.

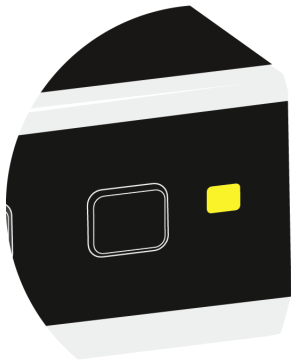

lights up red

No radio link to a transmitter. In addition, the background of the display panel changes back and forth between light and dark and **No Link** appears on the display panel.

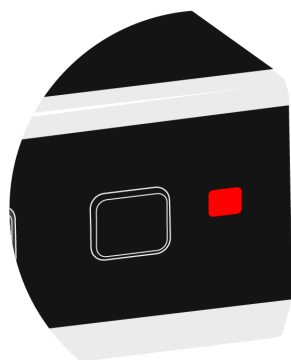

flashes red

The accupack capacity of the received transmitter is only sufficient for max. 30 minutes of operation.

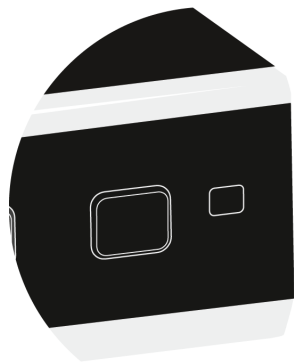



Connecting the receiver

Connecting the receiver to the power supply system

Only use the included power supply unit (NT 12-4 C or NT 2-3) to connect the receiver to the power supply system.

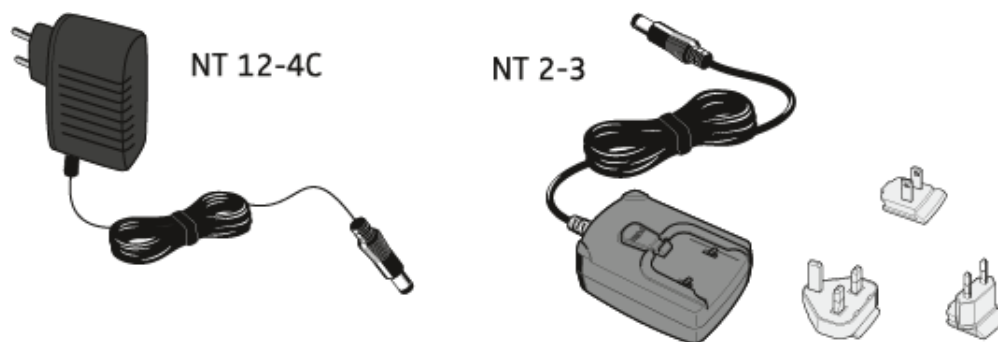

If you use the NT 2-3 power supply unit:

- ▶ Slide the supplied country adapter onto the power supply unit.

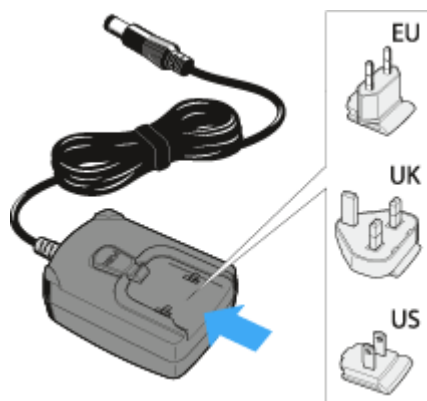

- ▶ Pass the cable of the power supply unit through the strain relief grip as shown.

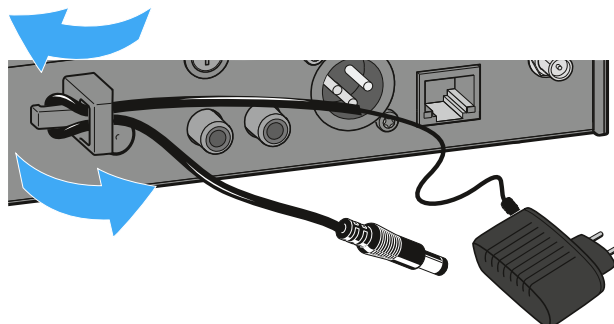

- ▶ Connect the hollow jack plug of the power supply unit to the DC IN socket of the receiver.

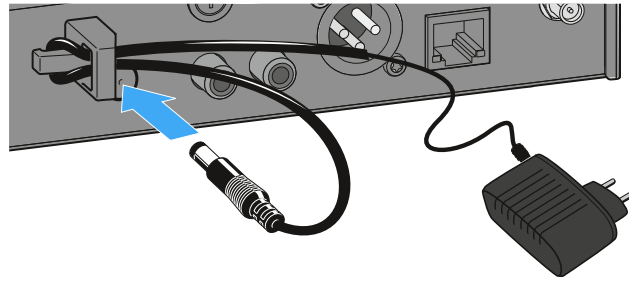

- ▶ Plug the power supply unit into the wall socket.

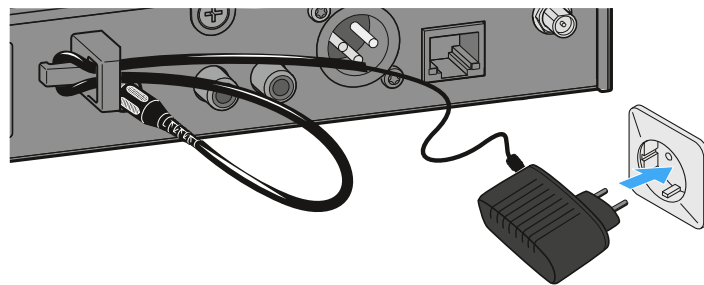

Connecting an amplifier or mixing console to the receiver

- i** The unbalanced audio output (RCA) and the balanced audio output (XLR) at the rear of the receiver are connected in parallel, allowing you to simultaneously connect two devices (e.g. amplifier and mixing console) to the receiver.

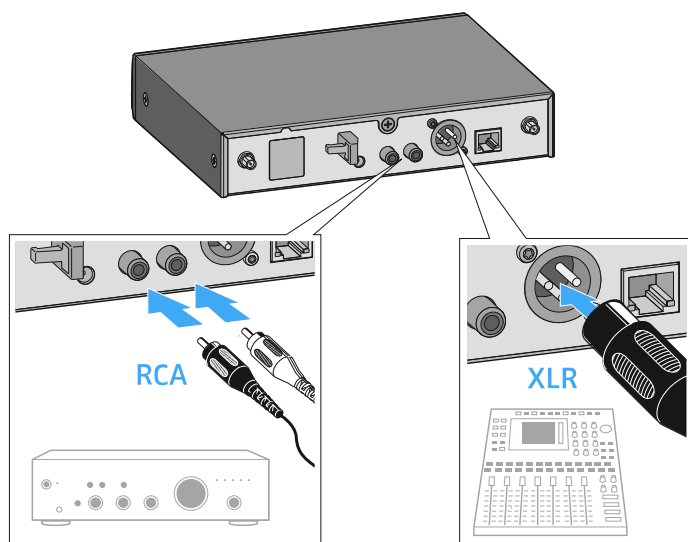

- ▶ Use a suitable audio cable to connect the amplifier or the mixing console to the appropriate audio output of the receiver.

i We recommend using the balanced audio output (XLR) because balanced cables are less prone to interference than unbalanced cables.



Controlling and monitoring the receiver via the network

You can connect several receivers in a network using a router or a switch. This allows you to control and monitor a larger SpeechLine Digital Wireless system using the **Sennheiser Control Cockpit** software.

For more information on controlling a system in the network using the **Sennheiser Control Cockpit** software, refer to the instruction manual of the software.

Please note that the host PC on which the **Sennheiser Control Cockpit** Service is installed must be in the same network as the devices that are to be monitored and controlled.

Connecting receivers in a network

- ▶ Connect a standard network cable (at least Cat 5) to the Ethernet socket LAN of your receiver.

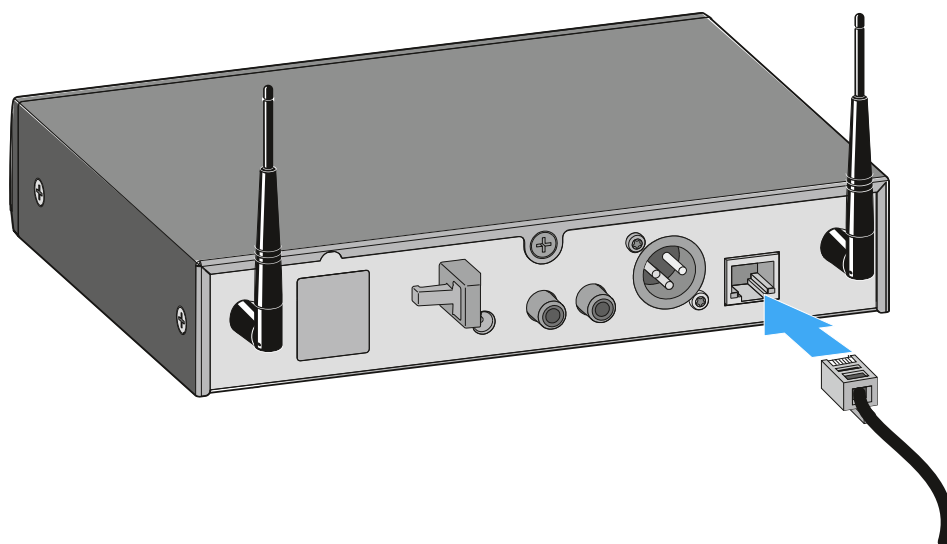

- ▶ Connect the other end of the network cable to a router or a switch.
- ✓ The **yellow LED** next to the LAN Ethernet socket of the receiver indicates the connection status:
 - On -> The receiver is connected to the network
 - Off -> The receiver is not connected to the network



Integrating the receiver into a network with DHCP

i The receiver obtains the IP address from the DHCP server.

- ▶ You can see this address in the **Network Settings** menu on the receiver (see [Using the operating menu of the receiver](#)).
- ▶ [Add the receiver in the Sennheiser Control Cockpit](#).

Integrating the receiver into a network without DHCP using Auto IP

i If there is no DHCP server in the network and you are working with automatically generated IP addresses, please observe the following information.

- ▶ Set the **Mode** to **Automatic** in the receiver's **Network Settings** menu.
- ▶ Ensure that the host PC on which the **Sennheiser Control Cockpit** service is installed is configured so that the IP address is assigned automatically, rather than a static configuration.
 - ✓ After several minutes, all receivers in the network will receive a link-local address in the range of 169.254.x.x. You can see this address in the **Network Settings** menu on the receiver (see [Using the operating menu of the receiver](#)).
- ▶ [Add the receiver in the Sennheiser Control Cockpit](#).

Integrating the receiver into a network without DHCP using Fixed IP

i If there is no DHCP server in the network and you are working with fixed IP addresses, please observe the following information.

- ▶ Set the **Mode** to **Fixed** in the receiver's **Network Settings** menu.
- ▶ Manually enter an IP address in the **IP** option in the receiver's **Network Settings** menu.
- ▶ [Add the receiver in the Sennheiser Control Cockpit](#).

To add the receiver in the Sennheiser Control Cockpit:

- ▶ Use the **Add Device** function in the **Sennheiser Control Cockpit** and enter the IP address you saw in the settings menu.
Or
- ▶ Activate the **mDNS** function in the receiver's **Network Settings** menu (factory setting: deactivated).



- ▶ Restart the receiver.
 - ✓ Once restarted, the receiver is automatically detected in the **Sennheiser Control Cockpit**.

i **mDNS = multicast Domain Name System:** resolves host names to IP addresses within small networks that do not include a local name server. Used for automatic device discovery.



Updating the firmware

The firmware of the receiver is updated using the **Sennheiser Control Cockpit** software.

You can find more information about this procedure in the software help within the software itself or the **download area** of the Sennheiser website.

[Control Cockpit](#)

sennheiser.com/download



Setting up the receiver

This sections describes how to set up the receiver.

You can also install the receiver in a fixed location, e.g. in a 19" rack. You can find more information about installing the receiver in a fixed location under: [Installing receivers in a rack](#).

Affixing the device feet

- i** Only affix the device feet if you are setting the receiver up in the stand-alone position instead of installing it in a 19" rack. The device feet will get in the way if the receiver is installed in a rack.

NOTICE



Risk of staining furniture surfaces

The device feet may cause marks if they come into contact with furniture surfaces.

- ▶ Do not place the device on sensitive surfaces.

- ▶ Clean the recesses for the device feet at the base of the receiver.
- ▶ Affix the device feet to the recesses of the receiver.
- ▶ Place the receiver on a flat, horizontal surface.
- ✔ The device feet will adhere reliably to the receiver only after some time. Avoid moving the receiver during this time.

Attaching the mounting angles

- i** The mounting angles are designed to help protect the operating elements from damage or deformation, e.g. if the receiver is dropped. We therefore recommend always attaching the mounting angles, even if you do not want to mount the receiver into a rack.

- ▶ Unscrew and remove the two recessed head screws on each side of the receiver.
- ▶ Secure the mounting angles to the sides of the receiver using the previously removed recessed head screws.



- ✓ Make sure that the angled ends of the mounting angles point forward.

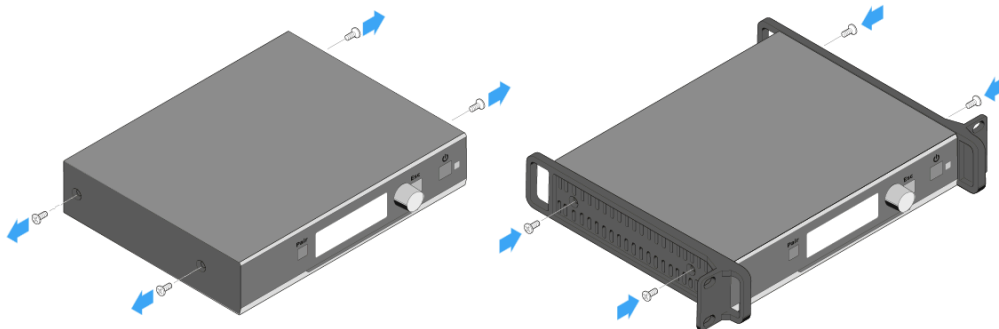

Connecting the rod antenna to the receiver

- ▶ Screw the two rod antennas into the receiver's two antenna sockets ANT I and ANT II, as shown.
- ▶ Align the rod antenna vertically.

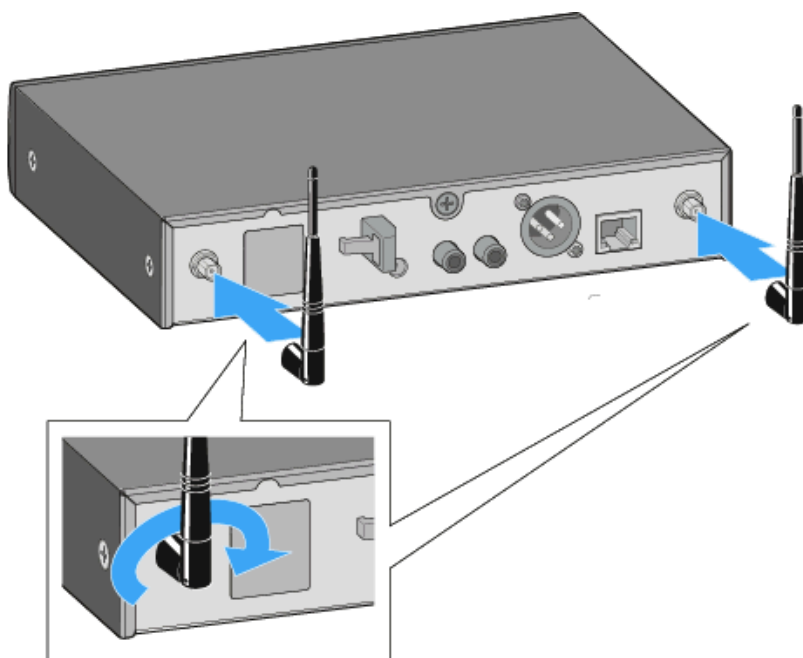

Connecting the AWM 2 / AWM 4 remote antenna to the receiver

i Instead of the supplied rod antenna, you can also connect a remote antenna to the receiver. For more information, see [AWM 2 / AWM 4 remote antennas](#).

- ▶ Pay attention to the notes about antenna installation under [Recommendations on antenna mounting](#).



Installing receivers in a rack

This chapter describes how to install a single receiver or two receivers side by side in a rack.

You can also set up the receiver without installing it in a fixed location. You can find more information about setting up the receiver under: [Setting up the receiver](#).

NOTICE

Danger due to high temperature, mechanical loading or electric leakage currents

When rack mounted, a receiver can be damaged by excessive heat or mechanical stress.

- ▶ Make sure that the temperature within the rack does not exceed the permissible temperature limit specified in the specifications.
- ▶ Make sure that the receivers in the rack are not subject to mechanical stress.
- ▶ Make sure that circuits are not overloaded by providing overcurrent protection if necessary.
- ▶ Make sure that the sum of the leakage currents of all power supply units do not exceed the allowable limit values by grounding the rack via an additional ground connection, if necessary.

You need the GA 4 mounting kit to install the receiver in a rack, see [GA 4 mounting kit](#).

Fastening the mounting angles (to install a receiver)

- ▶ Unscrew and remove the two recessed head screws on each side of the receiver.
- ▶ Secure the mounting angles to the sides of the receiver using the previously removed recessed head screws.
- ✓ Make sure that the angled ends of the mounting angles point forward.

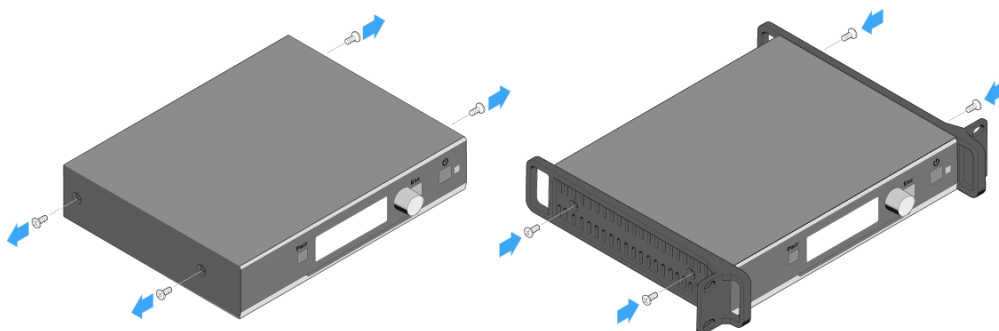



Installing the receiver in a rack

- ▶ Use the two supplied recessed head screws to secure the blanking plate from the GA 4 mounting kit to the mounting angle of the receiver as shown.
- ✓ Make sure to use the correct side (the one with the round holes) of the blanking plate to secure it to the mounting angle.

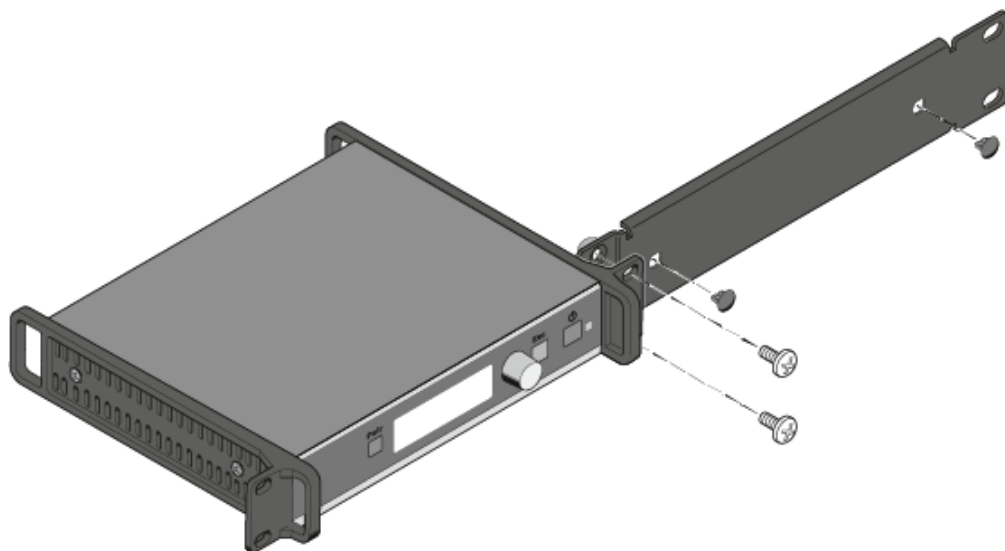

- ▶ Only insert the two small covering caps into the antenna holes if you do not wish to install the rod antenna at the front of the rack.
- ▶ Slide the receiver with the attached mounting accessories into a 19" rack.



Mounting the rod antenna to the front of the rack

- ▶ Connect the included antenna cables to the antenna sockets at the rear of the receiver.
- ▶ Pass the other ends of the antenna cables through the antenna holes in the blanking plate and screw them to the rod antenna as shown.

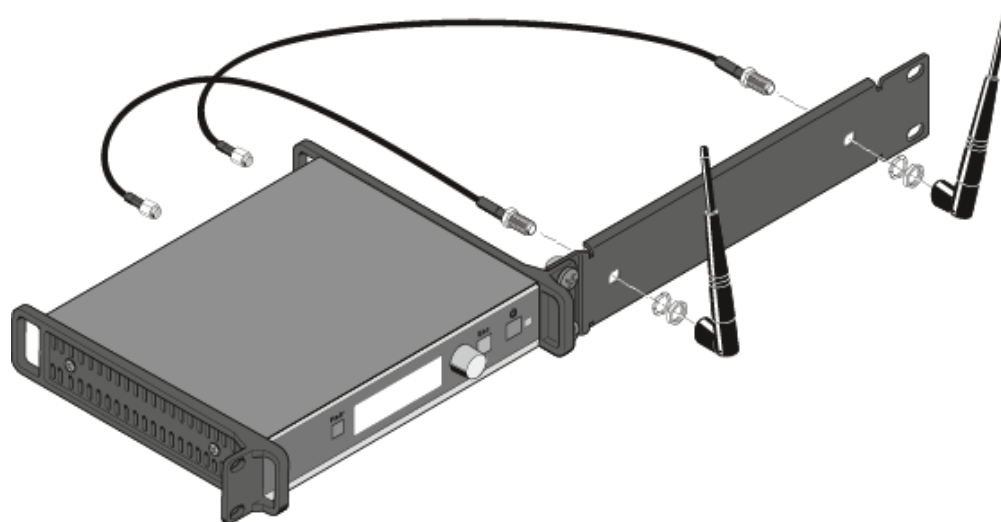

Mounting the jointing plate and fastening the mounting angles (to install two receivers side by side)

- ▶ Unscrew and remove the two recessed head screws on the outward-facing sides of the receiver.
- ▶ Secure the mounting angles to the outward-facing sides of the receiver using the previously removed recessed head screws.
- ▶ Place the two receivers side by side upside-down onto a flat surface.



- ▶ Secure the jointing plate to the receiver using the six recessed head screws as shown.

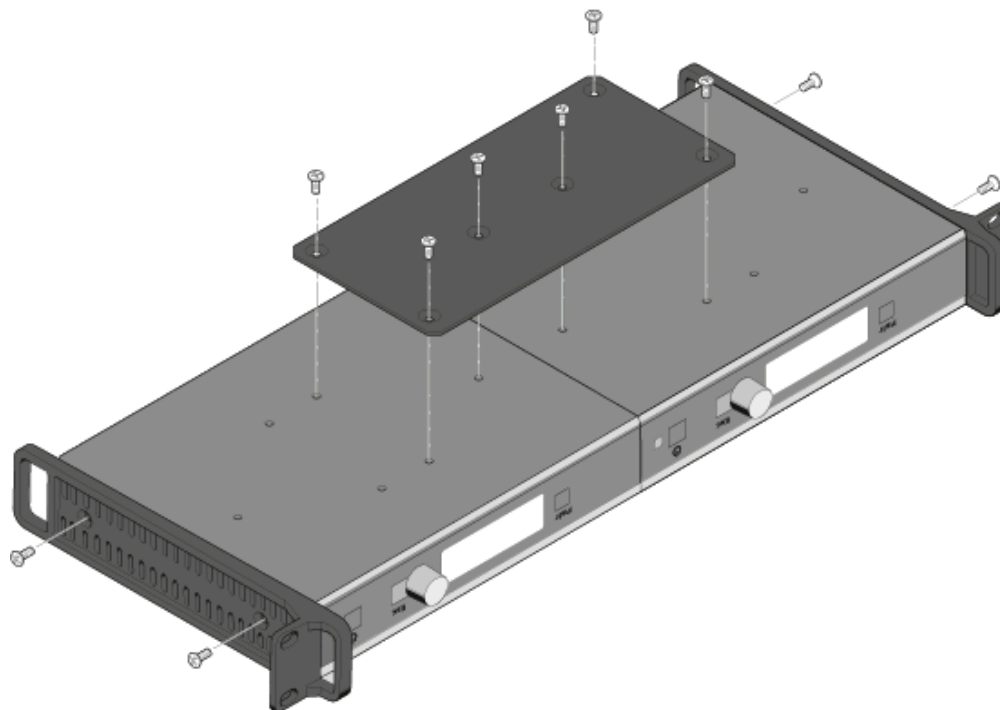

Connecting the AWM 2 / AWM 4 remote antenna to the receiver

i Instead of the supplied rod antenna, you can also connect a remote antenna to the receiver. For more information, see [AWM 2 / AWM 4 remote antennas](#).

- ▶ Pay attention to the notes about antenna installation under [Recommendations on antenna mounting](#).



Switching the receiver on and off

To switch the receiver on:

- ▶ Short-press the STANDBY button.

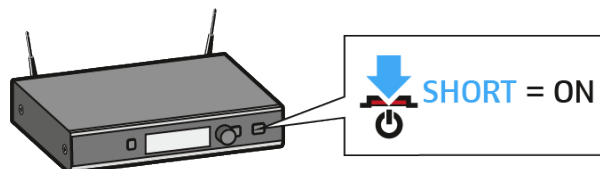

- ✓ The display panel first shows a logo and then the home screen appears. The status LED indicates the current status of the receiver. The radio link to the last paired transmitter is established automatically as soon as the transmitter is switched on.

To switch the receiver off:

- ▶ Long-press the STANDBY button.

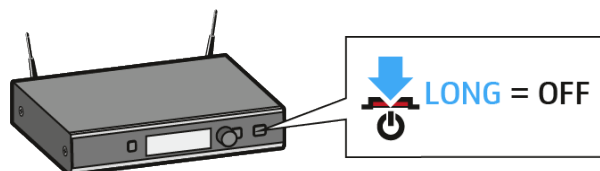

- ✓ The display panel and the status LED go off.



Displays on the receiver's display panel

Home Screen

The home screen appears automatically after switch-on or when no button has been pressed on the receiver for a long period of time.

If there is no radio link between the receiver and a transmitter, **No Link** appears on the display panel and the display brightness is automatically dimmed.

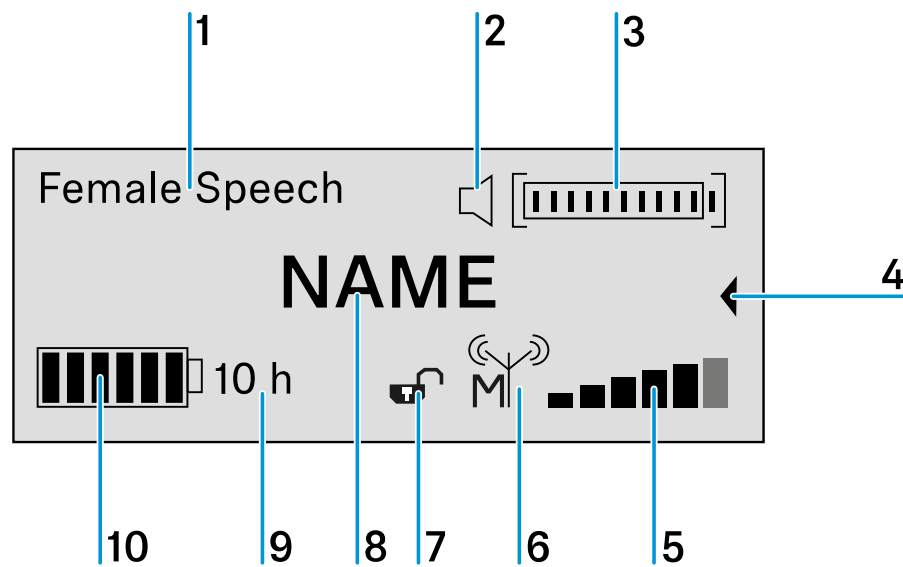

1 Selected sound profile

Displays the name of the selected sound profile. If no sound profile is selected, nothing is displayed here.

2 MUTE status display



The received transmitter is not muted, but can be muted at any time.



The received transmitter is muted. In addition, the status LED lights up yellow.



The received transmitter cannot be muted because its MUTE switch is deactivated. see [The System Settings menu](#).

3 Audio level display

The audio level is automatically adjusted.



4 Secondary home screen

The secondary home screen appears when you turn the jog dial to the left.

The above shown home screen appears again after 10 seconds or when you turn the jog dial to the right.

5 6-step display for the RF signal level

Displays the current level of the RF signal

6 RF output power of the transmitter, indicating master or follower

Displays the RF output power of the received transmitter.

Indicates whether the device is a master or a follower:



The device is the master.



The device is a follower.



The device is a follower, but is not synchronized.



The synchronization status is unknown.

7 Lock mode



The lock mode function is activated. The lock mode is currently deactivated and the receiver can be operated.



The lock mode function is activated. The lock mode is currently activated. Long-press the jog dial to temporarily deactivate the lock mode.

If no padlock icon is displayed, the lock mode function is deactivated.

see [The System Settings menu](#).

8 Name of the radio link

The name of the radio link can be configured freely. See [The Device Identification menu](#).

9 Expected remaining battery life of the received transmitter

Displays the remaining battery life of the received transmitter in hours (only when the original Sennheiser BA 10, BA 30 and BA 40 accupacks are used).

The remaining battery life is not displayed when batteries or rechargeable AA size batteries are used.



10 7-step display of the accupack or battery capacity

Graphically displays the current charge status of the accupack or the batteries.

Secondary Home Screen

When you turn the jog dial to the left from the home screen, the secondary home screen appears.

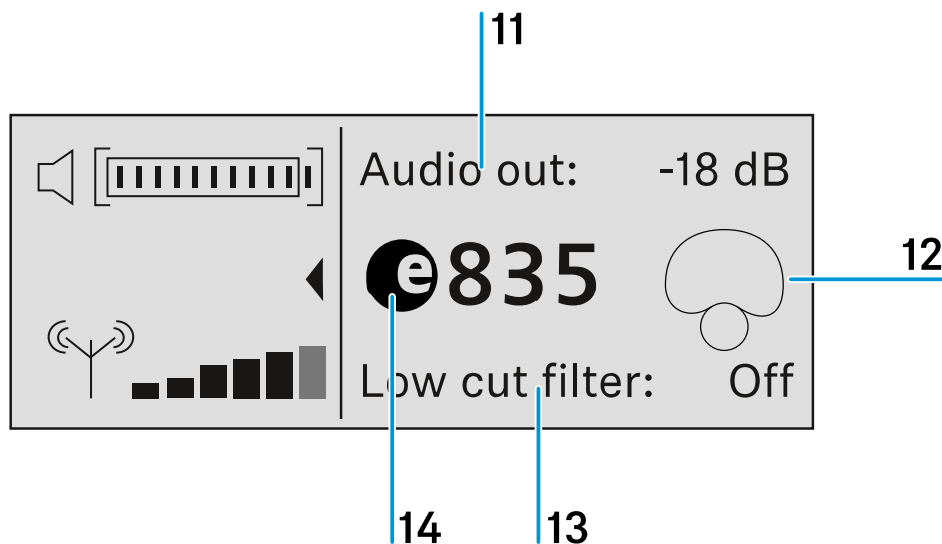

11 Audio output level of the receiver

12 Pick-up pattern of the microphone used

13 Status of the low-cut filter (ON/OFF)

14 Product name of the microphone capsule used



Using the operating menu of the receiver

Using the buttons for navigation

Press the **STANDBY** button



- Short-press: Switches the receiver on
- Long-press: Switches the receiver off

Short-press the **ESC** button



- Navigates to the next higher level in the menu
- Exits the menu item without storing changes to the settings

Press the **ESC** button for 3 seconds



- Returns to the home screen

Press the jog dial



- Changes from the home screen to the operating menu
- Calls up the selected menu item
- Changes to the selected submenu
- Confirms the selection or the changed setting

Turn the jog dial



- Switches between the home screen and the secondary home screen
- Changes to the previous or next menu item
- Changes the settings of a menu item

The menu structure of the receiver

Version: Firmware Version 2.6.10

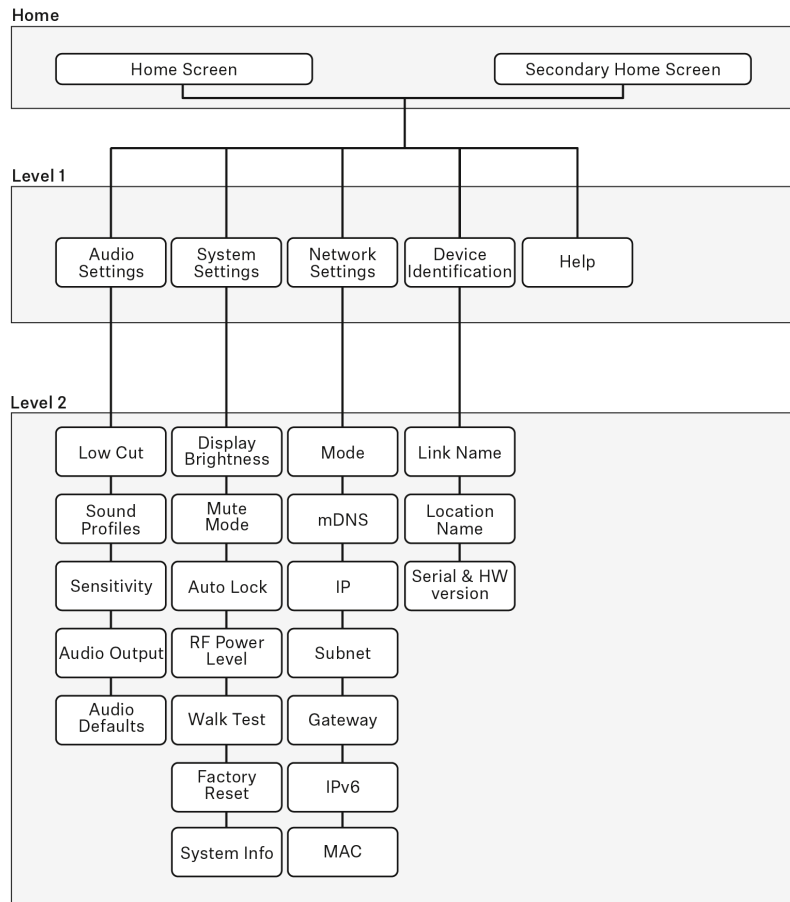

The Audio Settings menu

The **Audio Settings** menu at menu level 1 allows you to adjust the following settings.

Low Cut

- On: The low cut filter is activated. Low-frequency noise is filtered out.
- Off: The low cut filter is deactivated.

Sound Profiles

- Off: No sound profile is activated.
- Female Speech: Recommended sound profile for female speakers.
- Male Speech: Recommended sound profile for male speakers.
- Media: Recommended sound profile for other audio devices.
- Custom: 7-band equalizer for manually adjusting the sound settings.

Sensitivity

- Automatic: The audio sensitivity is automatically adjusted during speech.
- 0 dB ... -30 dB: The audio sensitivity can be manually adjusted in increments of 6 dB between 0 dB and -30 dB.



Audio Output

- Level: Slider for adjusting the audio output level of the XLR socket between **Mic Level** and **Line Level**.
- This setting does not affect the RCA output. This output always issues a line signal.

Audio Default

- Yes: Resets the audio settings (Low Cut and Sound Profiles) to the factory defaults.
- No: Keeps the current audio settings.

The System Settings menu

The **System Settings** menu at menu level 1 allows you to adjust the following settings.

Display Brightness

- Level: Slider for adjusting the display brightness.

Mute Mode

- Active: The MUTE switch of the paired transmitter is activated and can be used.
- Deactivated: The MUTE switch of the paired transmitter is deactivated and cannot be used.
- Push to talk: Press and hold the MUTE switch of the paired transmitter to activate the audio signal (for SL Boundary 114-S DW and SL Tablestand 133/153-S DW only).
- Push to mute: Press and hold the MUTE switch of the paired transmitter to mute the audio signal (for SL Boundary 114-S DW and SL Tablestand 133/153-S DW only).

Auto Lock

- On: The automatic lock mode is activated. If no button is actuated on the receiver for approx. 10 seconds, the lock mode is automatically activated.
 - Long-press the jog dial to temporarily deactivate the lock mode.
- The automatic lock mode is deactivated.

RF Power

- Automatic: The transmission power is automatically adjusted.
- Level 1 ... 5: The transmission power can be manually reduced in 5 steps. This function is required for operation in Multi-Room Mode.

Walk Test

- Starts the walk test. See [Performing a walk test \(reception quality\)](#)

Factory Reset

- Yes: All settings are reset to the factory defaults.
- No: The settings are retained.



System Info

- Displays the serial number and the current firmware version of the receiver.

The Network Settings menu

The **Network Settings** menu at menu level 1 allows you to adjust the following settings.

Mode

- Automatic: The IP address is automatically assigned using DHCP. If no DHCP server is available, the IP address is assigned by the SL Rack Receiver DW itself.
- Fixed IP: The IP address has to be entered manually.

mDNS

- Disabled: Deactivates mDNS to reduce the data volume transferred across the network. This option is recommended for larger systems.
- Enabled: Activates mDNS to allow for automatic device detection. This option is recommended for smaller systems with up to 30 devices.

IP

- Input of the IP address in **Fixed IP** mode

Subnet

- Input of the subnet mask in **Fixed IP** mode

Gateway

- Input of the gateway in **Fixed IP** mode

IPv6

- Displays the IPv6 address

MAC

- Displays the MAC address

The Device Identification menu

The **Device Identification** menu at menu level 1 allows you to adjust the following settings.

Link Name

- Input of the name of the radio link between the transmitter and the receiver. This name is also shown on the transmitter's display panel.



Location Name

- Input of the name of the room in which the receiver is set up.

Serial Number

- Displays the serial number and the hardware version of the receiver.

The Help menu

The **Help** menu at menu level 1 allows you to adjust the following settings.

Product Information

- QR Code with link to the product page of SpeechLine Digital Wireless.

User Manual

- QR Code with link to download the instruction manual.



SL MCR DW

The SpeechLine Multi-Channel Receiver with its 2 or 4 channels is the perfect addition to the SpeechLine Digital Wireless series. Thanks to its unobtrusive design, the Multi-Channel Receiver can be installed quickly and easily in any room, whether on the wall or ceiling.

Product overview and operating elements

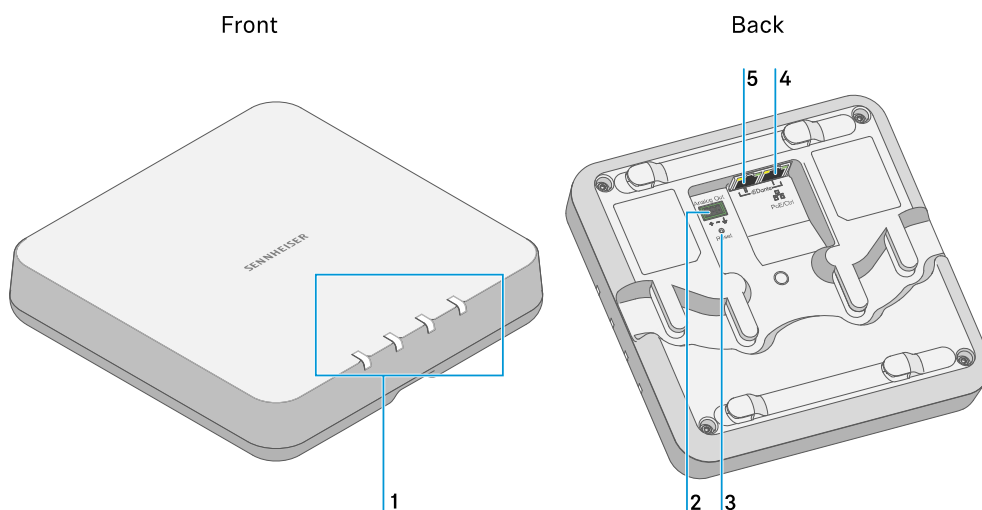

1 Status LEDs

See [Meaning of the status LEDs](#)

2 Analog Out 3-pin socket

Analog audio output (see [Connecting the receiver](#))

passend für Phoenix Contact MCVW 1.5-3-ST-3.81

3 Reset button

To restore the factory settings

Hold for 5 seconds

4 Dante I / PoE / Ctrl RJ-45 socket

Digital audio output (see [Connecting the receiver](#))

PoE supply (Power over Ethernet) (Power over Ethernet) (see [Putting the receiver into operation](#))

Configuration via the **Sennheiser Control Cockpit** or a media control system (see [Controlling and monitoring the receiver via the network](#))

5 Dante II RJ-45 socket

Digital audio output (see [Connecting the receiver](#))



Directivity of the integrated antennas

The receiver has eight integrated antennas.

The directivity of the antennas is as follows.

Directivity: total

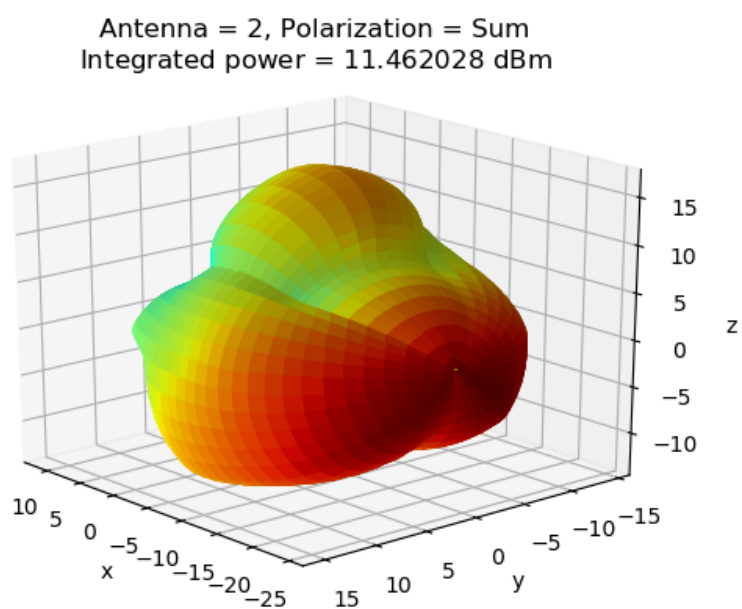



Polar diagram: total

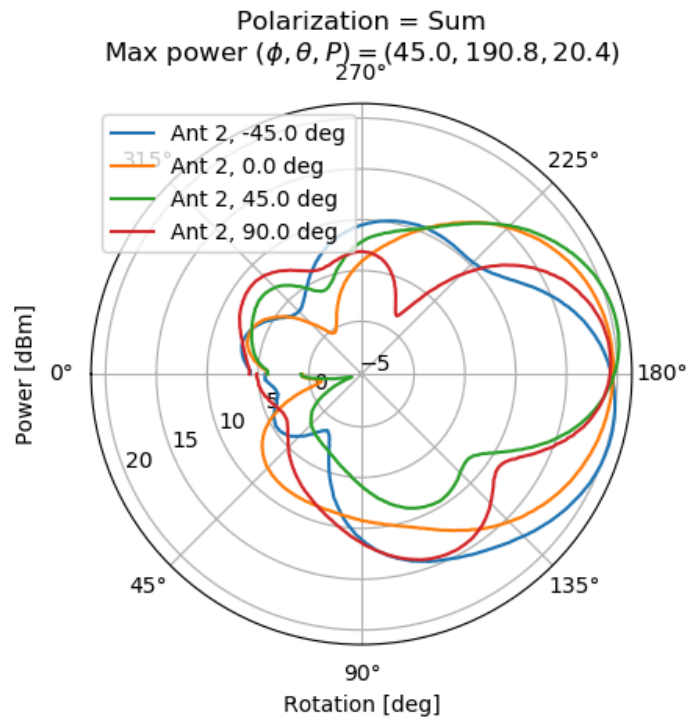

Polar diagram: horizontal

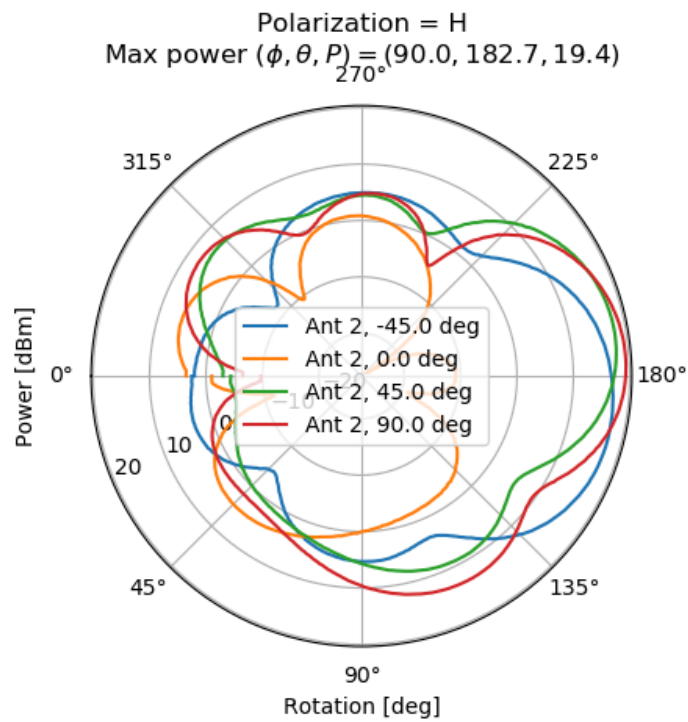



Polar diagram: vertical

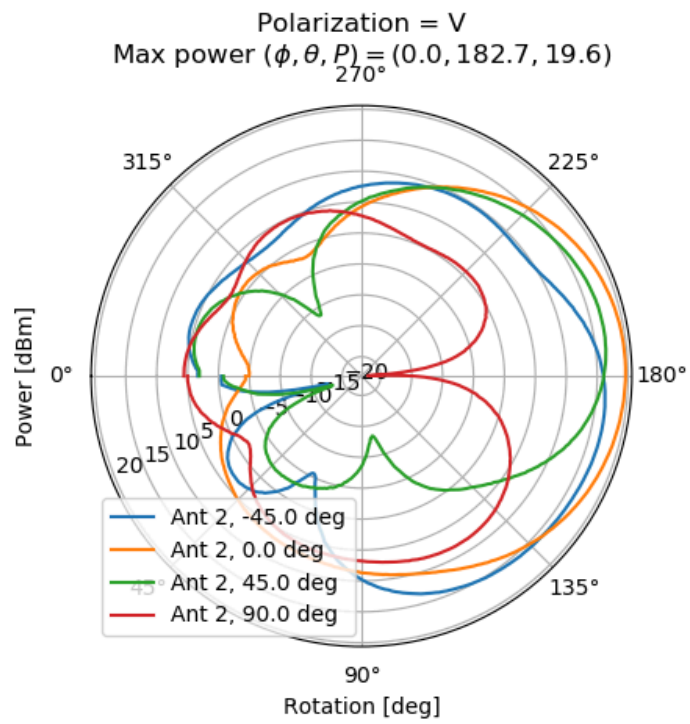



Connecting the receiver

The receiver can output analog and digital audio signals.

The analog audio signal is output via the 3-pin **Analog Out** terminal.

Digital audio signals are output via the **Dante** interface with two RJ-45 sockets. This interface is also used for control and configuration via the network and for **Power over Ethernet** supply.

The following variants are possible:

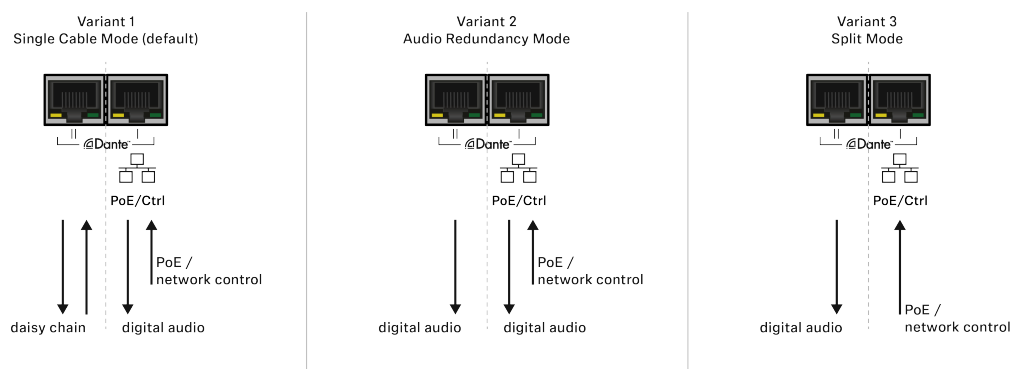

i To configure the variants you need the **Audinate Dante Controller** software: audinate.com.

Connecting to the network (power supply and configuration)

The **PoE/Ctrl** RJ-45 socket (**Dante I**) is used to both power the receiver via **Power over Ethernet** and configure it using the **Sennheiser Control Cockpit** software (see [Controlling and monitoring the receiver via the network](#)).

- In your network you can either use a switch that provides **PoE** or a **PoE** injector.

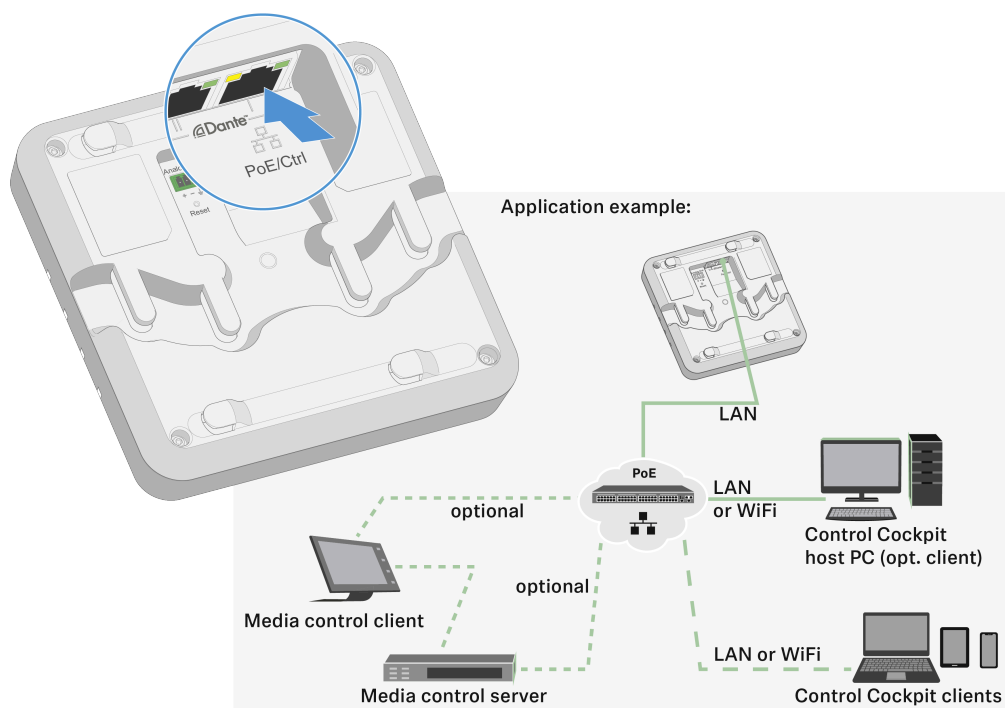

Outputting digital audio signals

The Dante® interface with two RJ-45 sockets, **Dante I** and **Dante II**, is used for outputting digital audio signals. The interface supports redundant output and daisy-chaining (see above for details).

- i** The digital audio output provides the signals from the individual channels (4 for the SL MCR 4 DW and 2 for the SL MCR 2 DW) as well as the sum signal of the channels. You can configure in the **Sennheiser Control Cockpit** whether the sum signal is mixed automatically or manually (see [Controlling and monitoring the receiver via the network](#)).

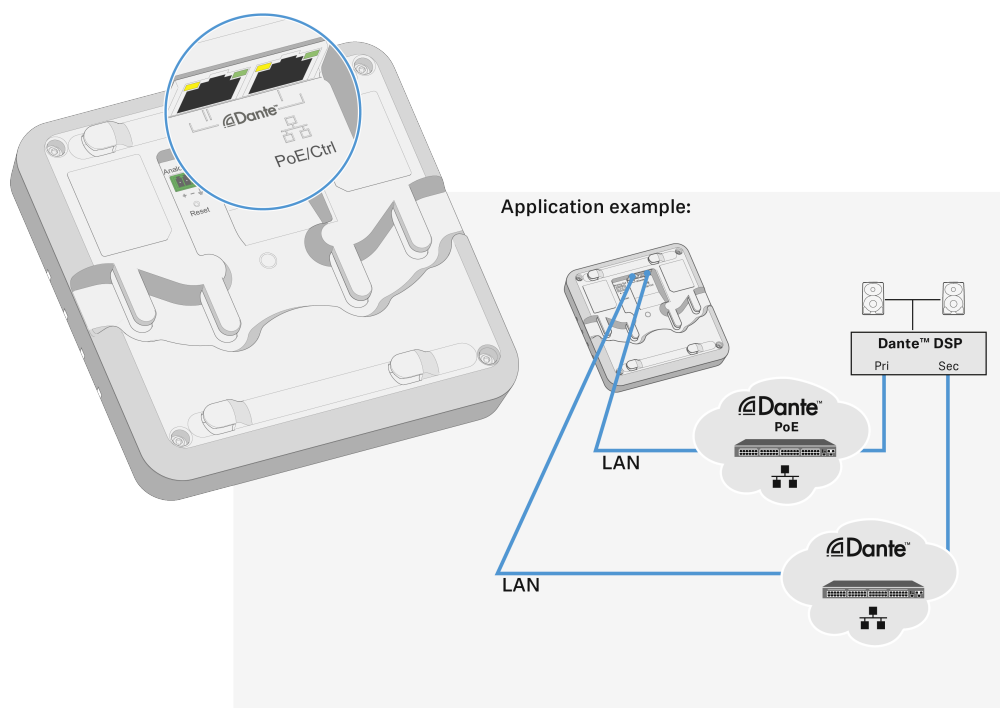

Outputting analog audio signals

The sum signal of all receiver channels is output from the **Analog Out** output.

- i** You can configure in the **Sennheiser Control Cockpit** whether the sum signal is mixed automatically or manually (see [Controlling and monitoring the receiver via the network](#)).

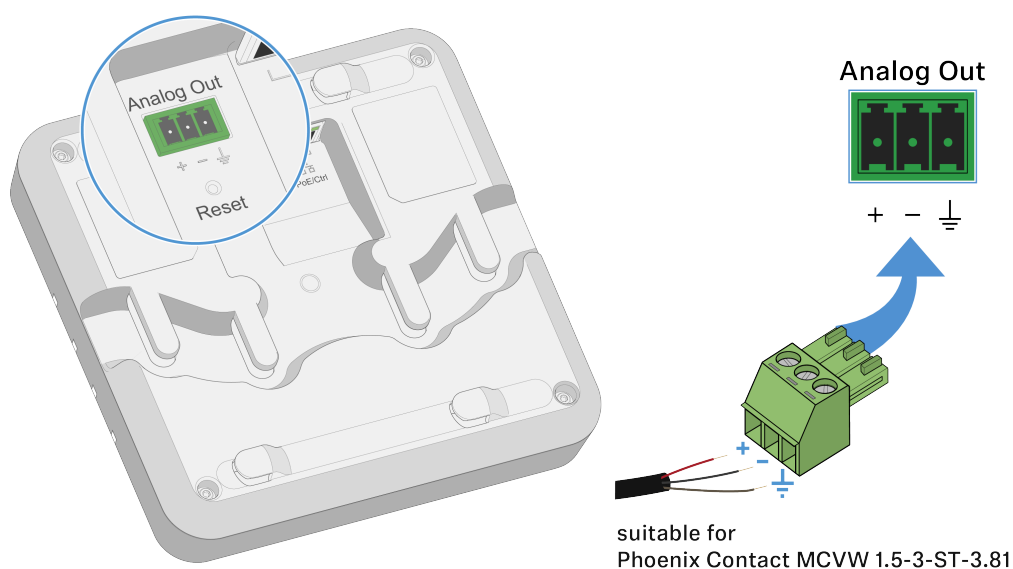



Mounting the receiver

Safety instructions for installation

Observe the following safety instructions when installing the product.

- ▶ The physical mounting and all electrical installations must be performed by a specialist.
- ▶ The specialist must have sufficient professional training, experience and knowledge of applicable provisions, regulations and standards to be able to properly assess the work assigned to them, identify possible hazards and take appropriate safety measures.
- ▶ When mounting the product, observe and follow all local, national and international regulations and standards.

The following mounting variants are available:

- [Mounting the receiver on the wall](#)
- [Mounting the receiver on the ceiling](#)
- [Mounting the receiver on a stand](#)
- [Mounting the receiver on a VESA mount](#)

Mounting the receiver on the wall

To mount the receiver on the wall, you will need the mounting frame supplied.

- i** Screws and anchors for mounting the product to the wall are not included with delivery. Use screws and anchors that are appropriate for the particular characteristics of your wall.

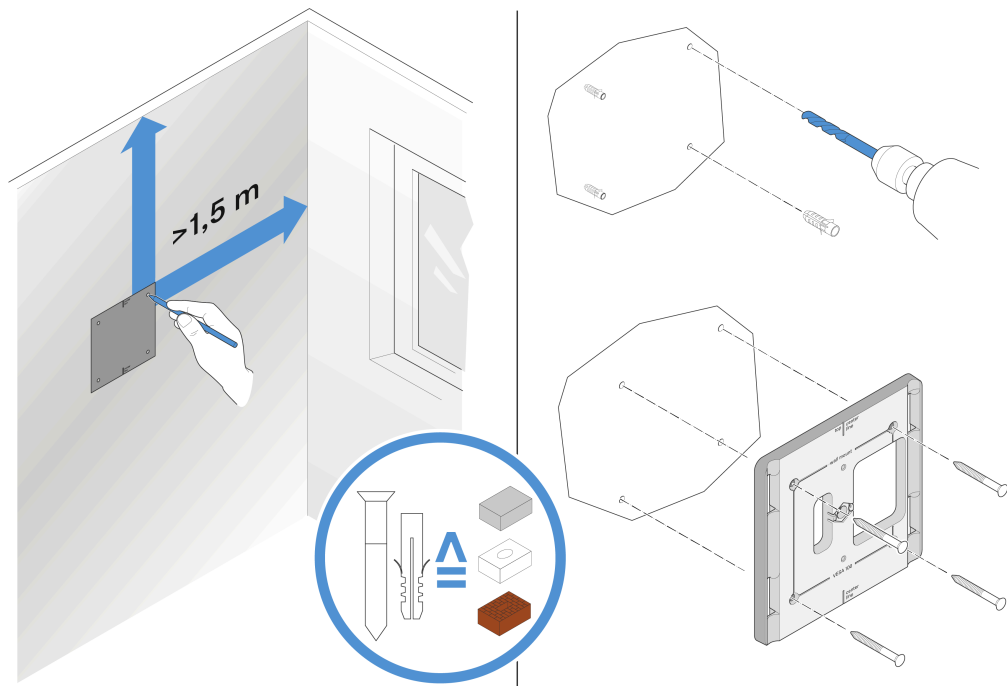

- ▶ Use the included drilling template to mark the drill holes for wall mounting.
- ▶ Maintain a minimum distance of 1.5 m from other walls and the ceiling.
- ▶ Screw the mounting frame to the wall using four suitable screws and anchors.

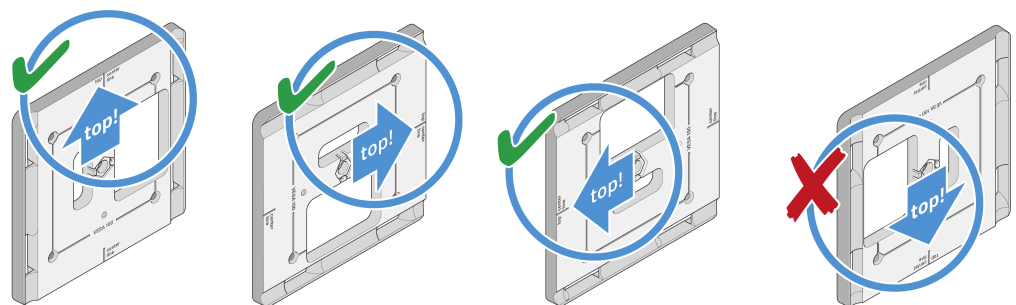

- ▶ Make sure that the mounting frame is aligned correctly.

NOTICE



Damage to the receiver due to incorrect mounting.

The receiver may fall out and be damaged.

- ▶ The top marking on the mounting frame must not point downwards.

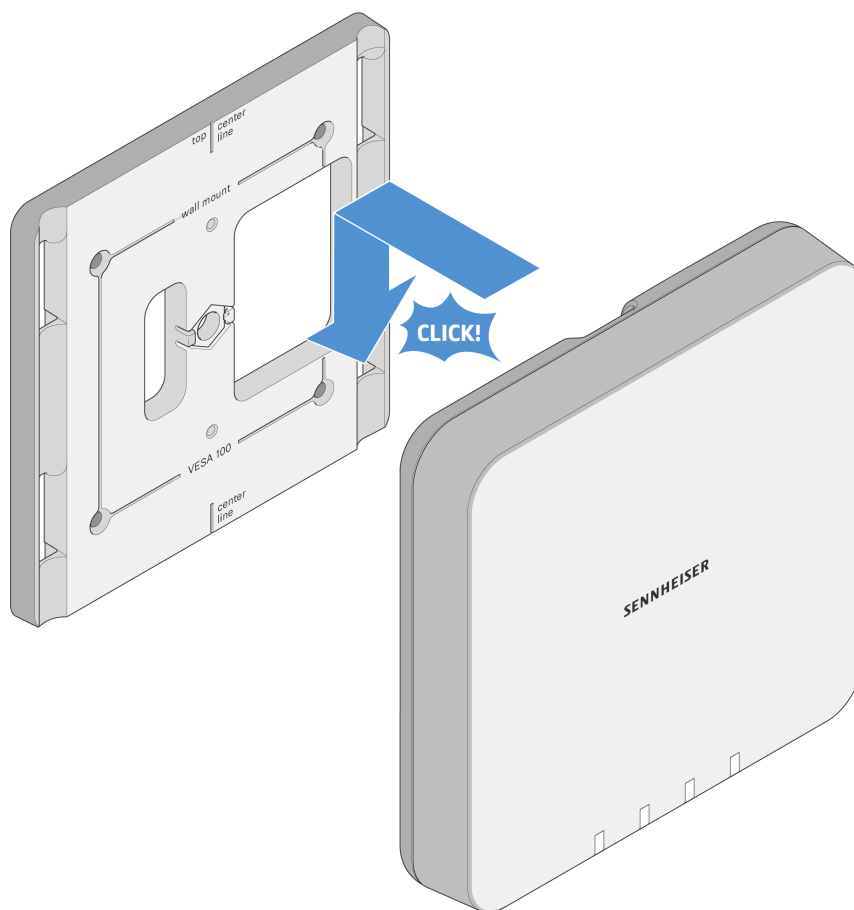

- ▶ Insert the receiver into the mounting frame as shown until you hear it click into place.



Mounting the receiver on the ceiling

To mount the receiver on the ceiling, you will need the mounting frame supplied.

- i** Screws and anchors for mounting the product to the wall are not included with delivery. Use screws and anchors that are appropriate for the particular characteristics of your wall.

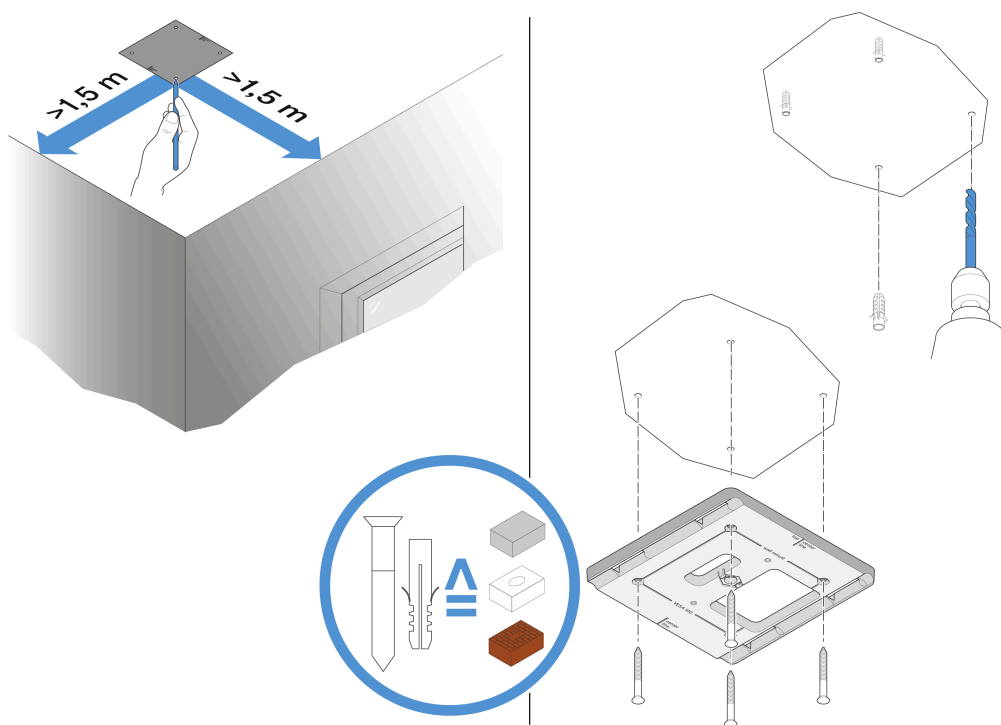

- ▶ Use the included drilling template to mark the drill holes for ceiling mounting.
- ▶ Maintain a minimum distance of 1.5 m from the walls.
- ▶ Screw the mounting frame to the ceiling using four suitable screws and anchors.

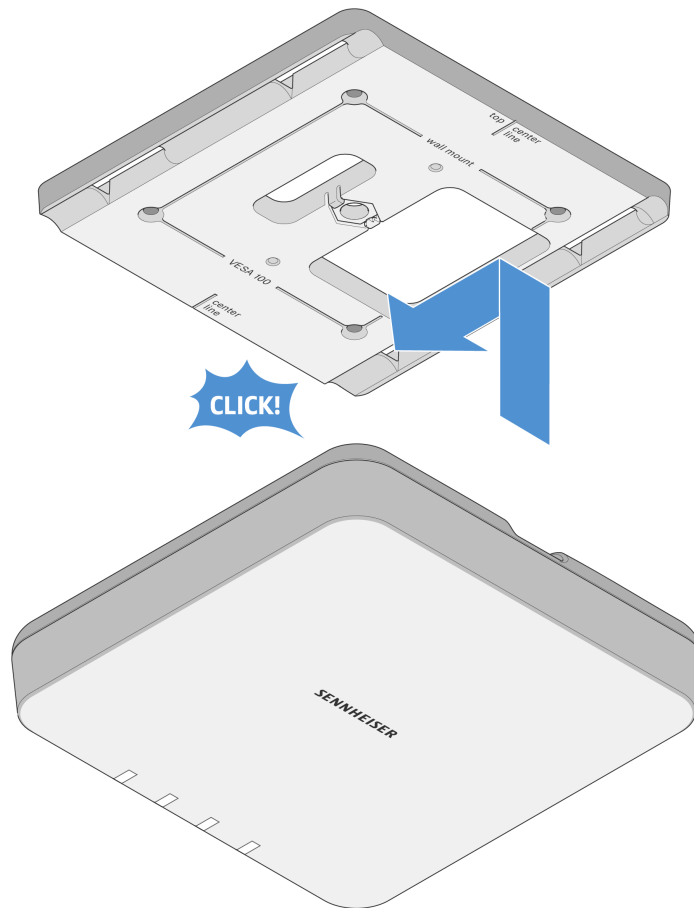

- ▶ Insert the receiver into the mounting frame as shown until you hear it click into place.



Mounting the receiver on a stand

The thread in the middle of the mounting frame is suitable for mounting on a standard microphone stand with boom arm and 3/8" thread.

CAUTION



Danger from falling objects

If you mount the receiver improperly on the stand, the stand and receiver may tip over. This can cause personal injury and damage to property.

- ▶ Use a stand that is designed for a central load of 5 kg.
- ▶ Adjust the length of the boom arm as short as possible, as shown in the figure.
- ▶ Set the height of the stand to a maximum of 2 meters.
- ▶ Make sure that the total weight of the stand and the mounted receiver does not exceed 7 kg.

- ▶ Screw the mounting frame onto the microphone stand as shown.
- ▶ Insert the receiver into the mounting frame as shown until you hear it click into place.

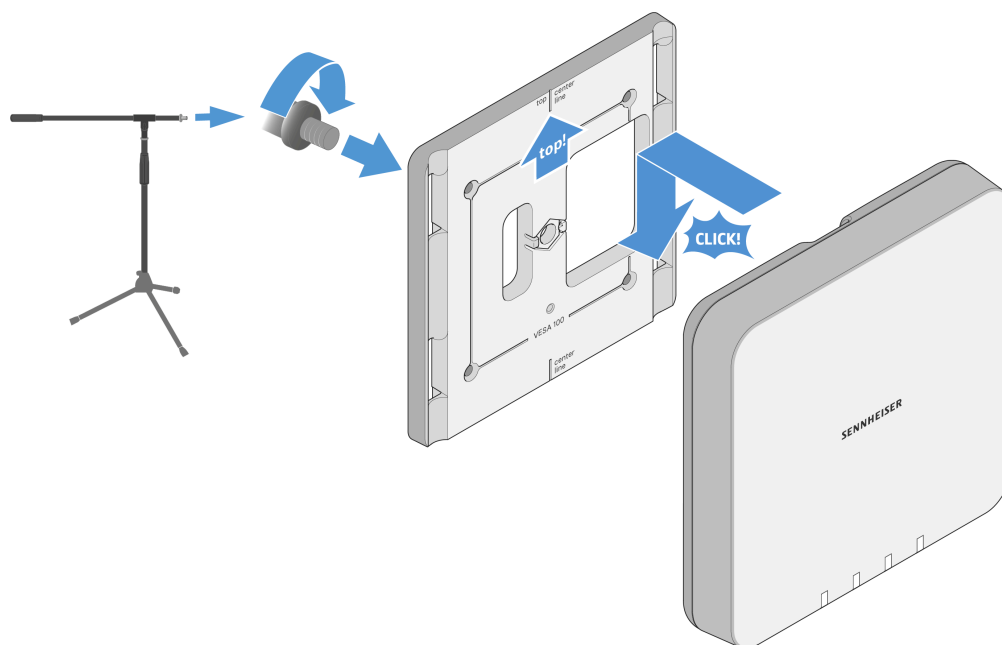



Mounting the receiver on a VESA mount

The holes in the mounting frame are positioned 100 mm apart so that the mounting frame can be mounted on any VESA 100 mount.

CAUTION



Danger from falling objects

If you mount the receiver incorrectly on the VESA mount, the VESA mount and receiver may fall down. This can cause personal injury and damage to property.

- ▶ Follow the installation and safety instructions from the manufacturer of the VESA mount.

- ▶ Screw the mounting frame onto the VESA mount as shown using four suitable screws.
- ▶ Insert the receiver into the mounting frame as shown until you hear it click into place.

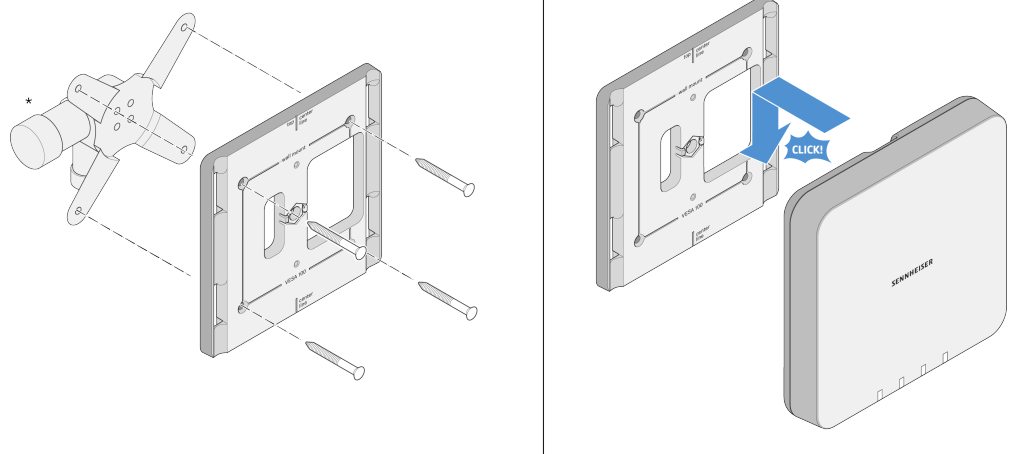

*Example of a VESA 100 mount



Putting the receiver into operation

Observe the following information during startup.

Connecting/disconnecting the receiver to/from the power supply system

The receiver is powered using **Power over Ethernet**. As soon as the power supply is established, the receiver switches on automatically. There is no separate on/off switch.

- See [Connecting to the network \(power supply and configuration\)](#)

When the receiver starts, all four LEDs light up green for about 20 seconds. Then the LEDs change to displaying the status of the respective channel.

- See [Meaning of the status LEDs](#)

Operating and configuring the receiver

The receiver is operated and configured using the **Sennheiser Control Cockpit** control software. You cannot operate the receiver on the device itself.

- See [Controlling and monitoring the receiver via the network](#)



Controlling and monitoring the receiver via the network

To configure and use the receiver, you need the free **Sennheiser Control Cockpit** control software. You can download it here:

sennheiser.com/control-cockpit-software

i To use the **Sennheiser Control Cockpit**, you must complete a one-time registration with your e-mail address to receive the software activation code.

The online help contains detailed information about the functions of the **Sennheiser Control Cockpit** and how to configure the **SL MCR DW** and the network. The online help can be found on the Sennheiser Control Cockpit product page and in the software itself.

sennheiser.com/control-cockpit-software

Using the media control protocol

You can control the **SL MCR DW** via a media control system using the **Sennheiser Sound Control Protocol**.

The documentation for the media control protocol can be found on the product page:

sennheiser.com/sl-mcr-dw



Meaning of the status LEDs

The four LEDs display status information for the device as a whole or for one of the two or four microphone channels.

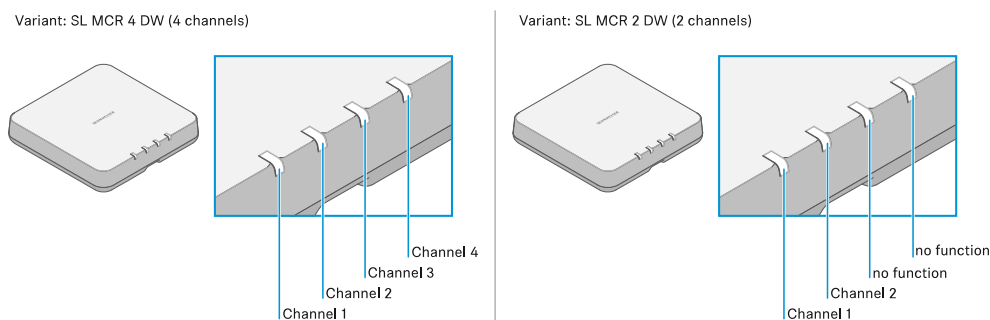

When the LEDs are displaying the status of the entire device and not the individual channels, all four LEDs (SL MCR 4 DW variant) or the first two LEDs (SL MCR 2 DW variant) will light up or flash.

The LEDs for each individual channel display status messages for the corresponding radio connection.

i Also note the additional information in the **Sennheiser Control Cockpit**.

All LEDs

All LEDs are green

SL MCR 2 DW & SL MCR 4 DW

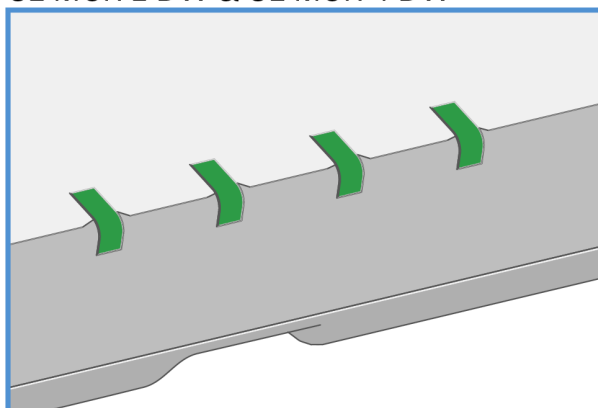

- After the power supply is switched on:
 - The device is starting (approx. 20 seconds). Afterwards the status information is displayed.
 - All four LEDs light up green during startup even with the two-channel variant SL MCR 2 DW.



SL MCR 4 DW

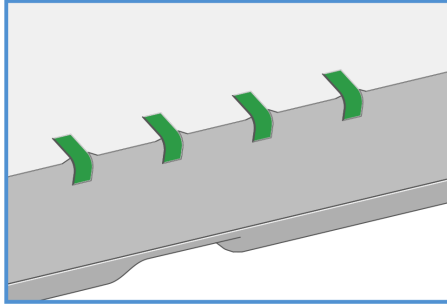

SL MCR 2 DW

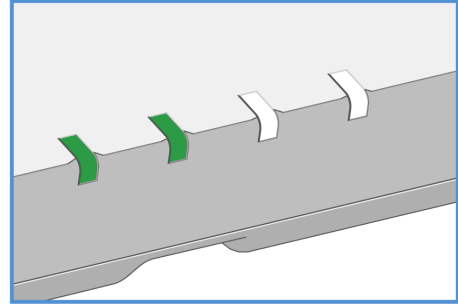

- During operation:

A radio link to the transmitters has been established for all channels.

All LEDs are flashing green

SL MCR 4 DW

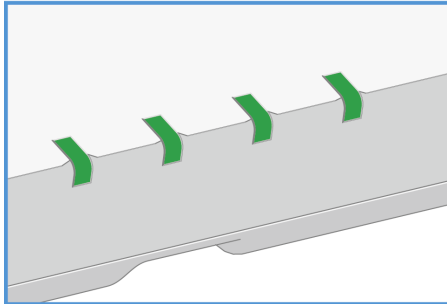

SL MCR 2 DW

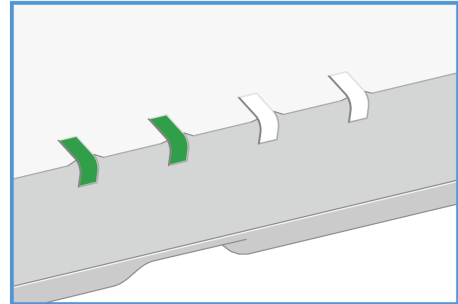

- The Identify function for the entire device was initiated in the **Control Cockpit**.

All LEDs are yellow

SL MCR 4 DW

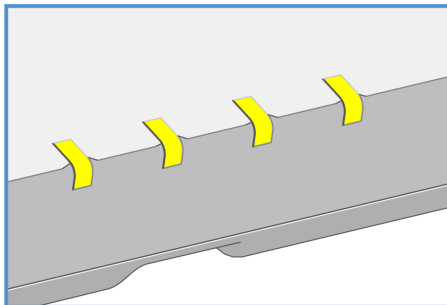

SL MCR 2 DW

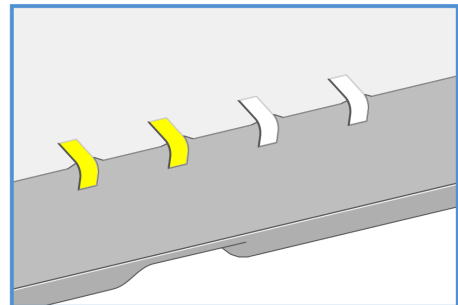

- All received transmitters have been muted with the **MUTE** switch.

All LEDs are flashing yellow



SL MCR 4 DW

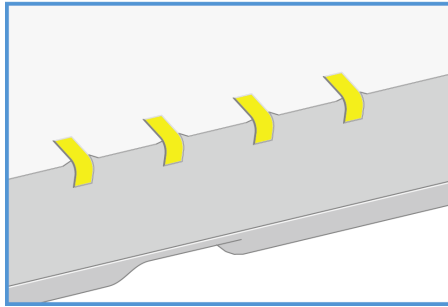

SL MCR 2 DW

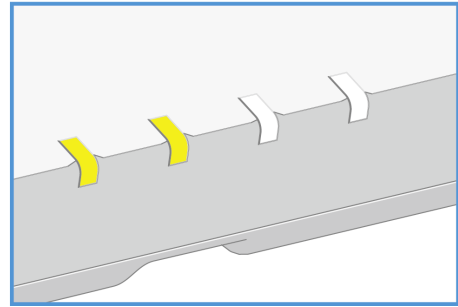

- The device is performing a firmware update.

See [Updating the firmware](#)

All LEDs are red

SL MCR 4 DW

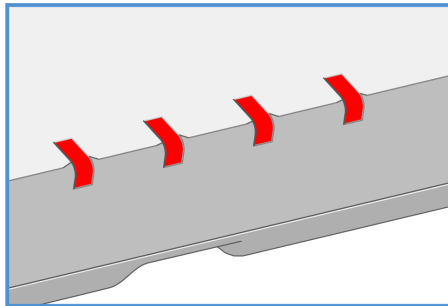

SL MCR 2 DW

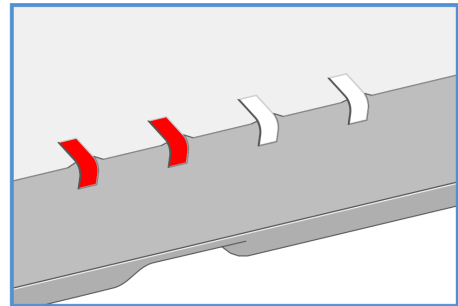

- There is no radio link to a transmitter for any of the channels.

All LEDs are flashing red

SL MCR 4 DW

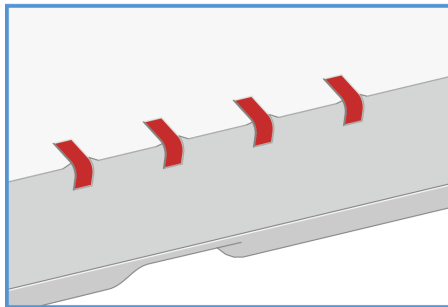

SL MCR 2 DW

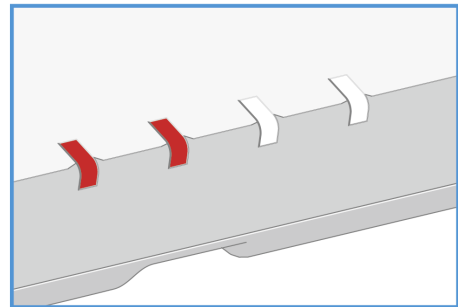

- A device error has occurred. Details are shown in the **Control Cockpit**.
- or
- An error occurred while updating the device firmware. Details are shown in the **Control Cockpit**.

A channel's LED

Is green

A radio link to the transmitter is established.

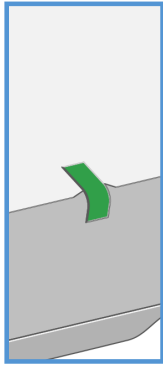

Is flashing green

The Identify function for this channel was initiated in the **Control Cockpit**.

The LED of the received transmitter also flashes.

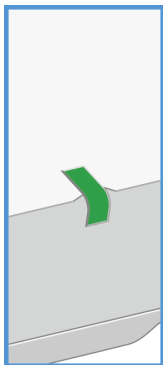

Is yellow

The received transmitter has been muted with the **MUTE** switch.

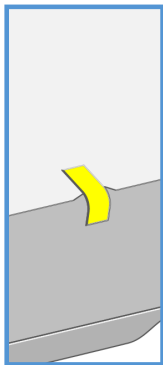

Is flashing yellow

The received transmitter is performing a firmware update.

See [Updating the firmware](#)

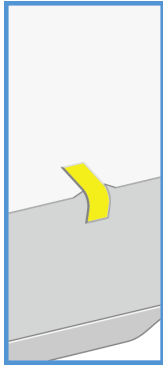

Is red

No radio link to a transmitter.

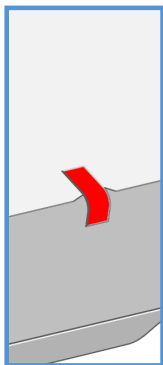

Is flashing red

An error has occurred in this channel. Details are shown in the **Control Cockpit**.

or

An error occurred while updating the transmitter firmware. Details are shown in the **Control Cockpit**.

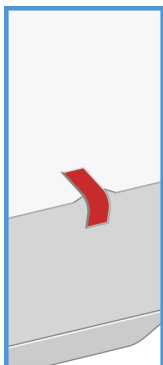

Flashes red and green in alternation

Pairing mode is active for this channel.

See [Pairing](#)

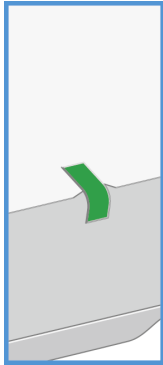



Updating the firmware

The firmware of the receiver and the received transmitter is updated using the **Sennheiser Control Cockpit** software.

You can find more information about this procedure in the software help within the software itself or the **download area** of the Sennheiser website.

[Control Cockpit](#)

sennheiser.com/download



The SL Handheld DW

The handheld transmitter (SL Handheld DW) is ideal when several persons are speaking at the same time, such as in interviews or when queries come from the audience. You can replace the microphone capsule if necessary. The handheld transmitter is supplied with the high-quality MME 865-1 microphone capsule. The MME 865-1 has excellent presence and high feedback rejection and is specially designed for speech applications.

Thanks to its easy handling, the handheld transmitter is available to the speaker for immediate use, and no further instruction is necessary. The functions of the handheld transmitter have been reduced to a minimum to allow stress-free speaking during the presentation and to ensure that the speaker is not distracted by unnecessary operating options.

Product overview

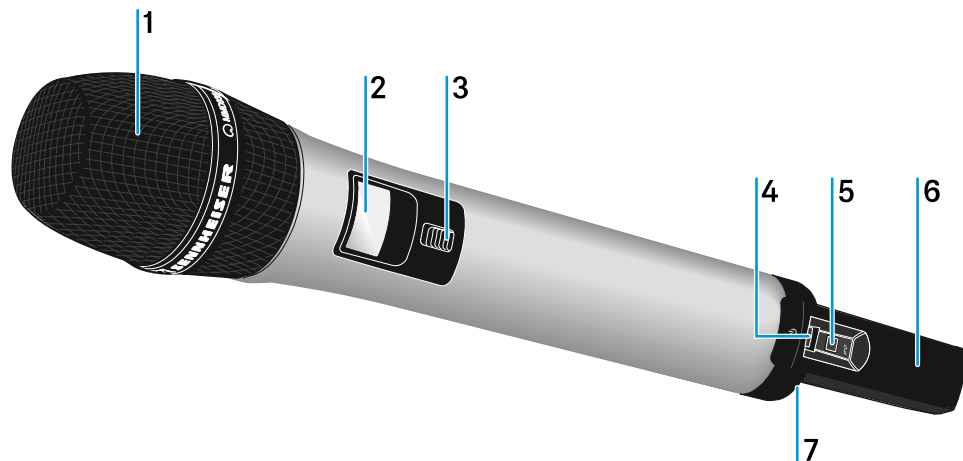

1 Unscrewable microphone head with microphone capsule

see [Using the handheld transmitter](#)

2 Display panel

see [Displays on the display panel](#)

3 MUTE switch

see [MUTE switch](#)

4 ON/OFF button with status LED

Short-press to switch the handheld transmitter on

Long-press to switch the handheld transmitter off

LED: see [Switching the handheld transmitter on and off](#)



5 PAIR button

Short-press to identify the paired receiver

Long-press to pair with a different receiver

see [Pairing](#)

6 Antenna

see [Using the handheld transmitter](#)

7 BA 10 accupack

see [Removing/inserting the accupack](#)



Displays on the display panel

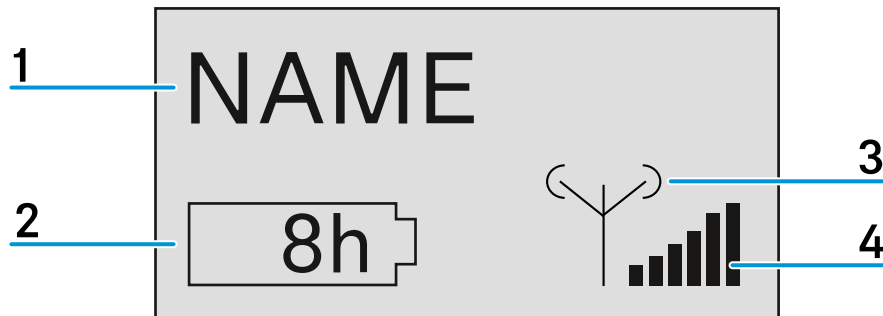

1 Name of the radio link

Can be entered in the Device Identification menu of the receiver (see [Using the operating menu of the receiver](#)).

2 7-step display of the accupack or battery capacity

Graphically displays the current charge status of the accupack or the batteries.

If you use the accupack, the remaining operating time is displayed in hours.

3 RF output power of the transmitter

Displays the RF output power of the handheld transmitter.

4 6-step display for the RF signal level

Displays the current level of the RF signal.



Removing/inserting the accupack

The accupack must be charged before the first use. The accupack can either be charged with the optional CHG 2 or CHG 4N chargers (see [The CHG 2N charger](#) or [The CHG 4N charger](#)) or with the supplied USB cable.

To remove the accupack:

- ▶ Simultaneously press the two unlock buttons and pull the accupack away from the handheld transmitter.

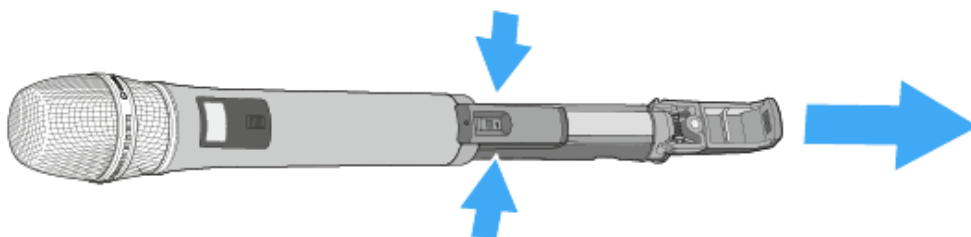

To insert the accupack:

- ▶ Slide the accupack onto the handheld transmitter as shown.
- ✓ The accupack or the battery compartment locks into place with an audible click.

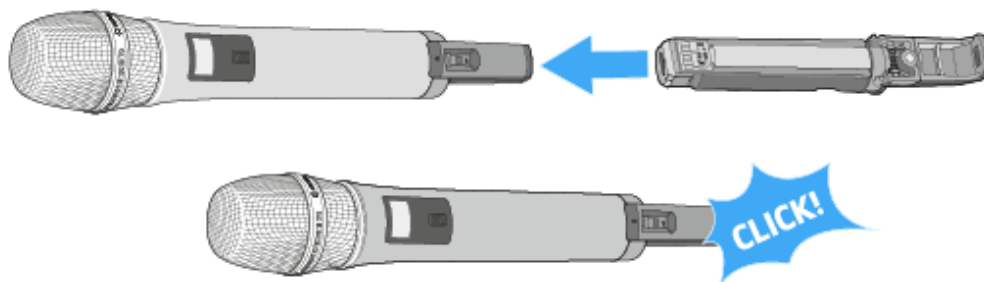



Switching the handheld transmitter on and off

- i** After switch-on, the receivers and transmitters will take approx. 10 seconds to establish the radio links.

To switch the handheld transmitter on:

- ▶ Short-press the ON/OFF button in the direction of the transmitter body.



- ✓ The home screen appears on the display panel (see [Displays on the display panel](#)). The status LED indicates the current status of the receiver (see [Meaning of the status LED](#)). The radio link to the last paired receiver is established automatically as soon as the receiver is switched on.

To switch the handheld transmitter off:

- ▶ Press the ON/OFF button for approx. 3 seconds in the direction of the transmitter body.



- ✓ The display panel and the status LED go off.



Meaning of the status LED

lights up green

A radio link to the receiver is established.
The accupack of the handheld transmitter is sufficiently charged.

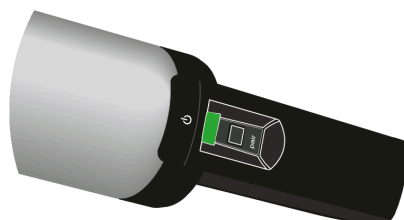

flashes green

The PAIR button has been short-pressed.
Paired devices are being identified.

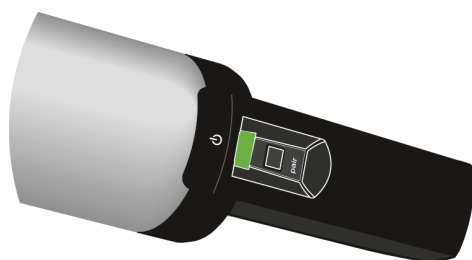

flashes alternately green and red

The PAIR button has been long-pressed. The handheld transmitter establishes a radio link to a receiver whose PAIR button has also been long-pressed.

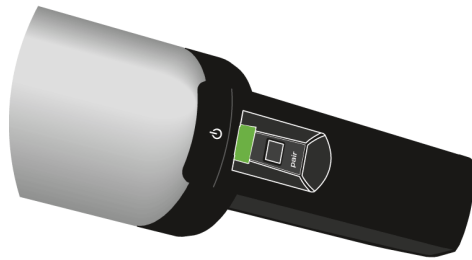

lights up yellow

The handheld transmitter has been muted with the MUTE switch. In addition, **Muted** is displayed on the display panel.

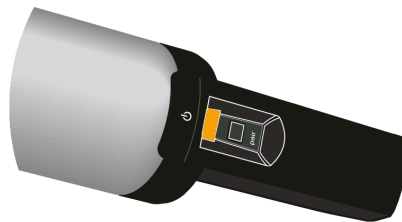

flashes yellow

The firmware is being updated.

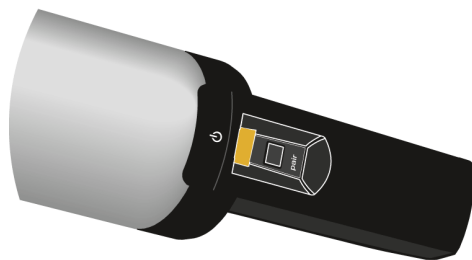



lights up red

No radio link to a receiver. In addition, **No Link** is displayed on the display panel.

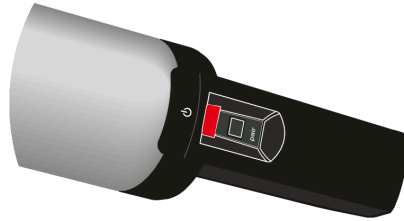

flashes red

The accupack capacity of the handheld transmitter is only sufficient for max. 30 minutes of operation.

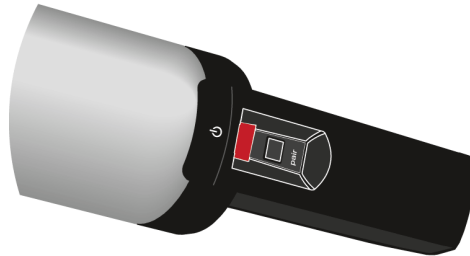



Using the handheld transmitter

The handheld transmitter is available with or without the MME 865-1 microphone capsule. The MME 865-1 has a pre-polarized condenser microphone capsule with super-cardioid pick-up patterns.

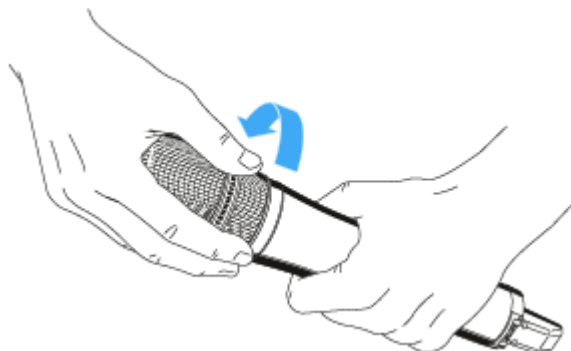

- ▶ The microphone capsule can be unscrewed and replaced by one with a different pick-up pattern.
If you touch the antenna of the handheld transmitter during transmission, the transmission range will be considerably reduced. If you cover the microphone capsule during transmission, this will change the pick-up pattern of the microphone and consequently the sound.
- ▶ Only hold the handheld transmitter by its body.

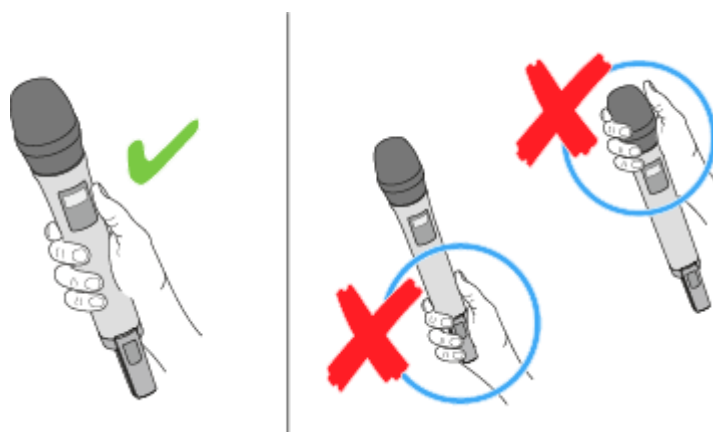

- ▶ Hold the handheld transmitter approx. 5 to 10 cm in front of your mouth.



The MME 865-1 microphone capsule has a super-cardioid pick-up pattern.

- ▶ Hold the handheld transmitter vertically and speak into the sound inlet basket from directly above.

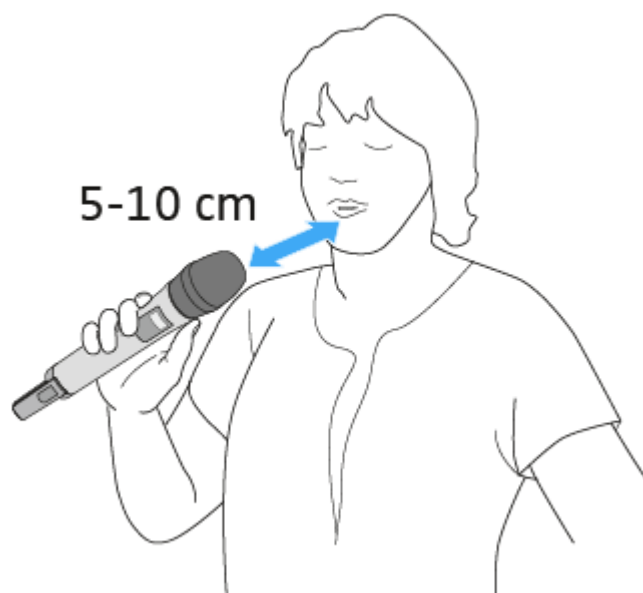



MUTE switch

The handheld transmitter can be muted with the MUTE switch. This only mutes the audio signal. The radio link remains active and the transmitter remains operational.

The MUTE switch can be deactivated in the System Settings menu of the receiver. With the MUTE switch deactivated, the handheld transmitter cannot be muted.

To mute the handheld transmitter:

- ▶ Slide the MUTE switch to the position **MUTE**.
- ✔ **Muted** appears on the display panel of the receiver. The status LED on both the handheld transmitter and the receiver lights up yellow.

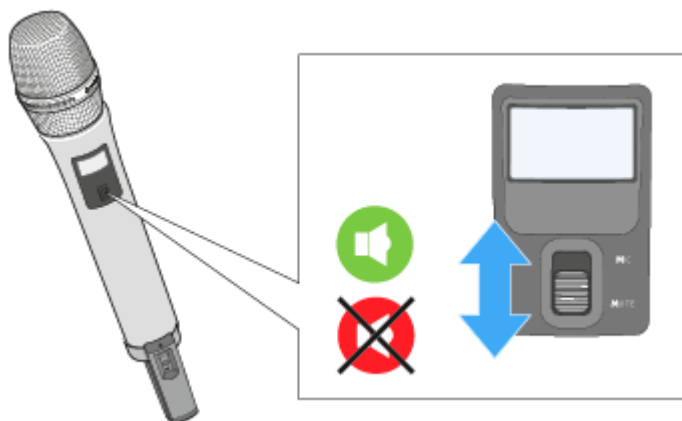

To cancel the muting:

- ▶ Slide the MUTE switch to the position **MIC**.



Updating the firmware

The firmware of the receiver and the received transmitter is updated using the **Sennheiser Control Cockpit** software.

You can find more information about this procedure in the software help within the software itself or the **download area** of the Sennheiser website.

[Control Cockpit](#)

sennheiser.com/download

- i** When updating the firmware, make sure that only the transmitter whose firmware is currently being updated is switched on. All other transmitters should be switched off.



The SL Bodypack DW

The compact, robust SL Bodypack DW bodypack transmitter is compatible with all Sennheiser headset and clip-on microphones (e.g. Headmic 1 or MKE 1). Thanks to the bi-directional communication between the transmitter and the receiver, no settings need to be adjusted on the transmitter. The transmitter's LC display indicates the link name, the battery status and the reception quality. With the easy-to-access mute switch, the transmitter can be muted if necessary.

Product overview

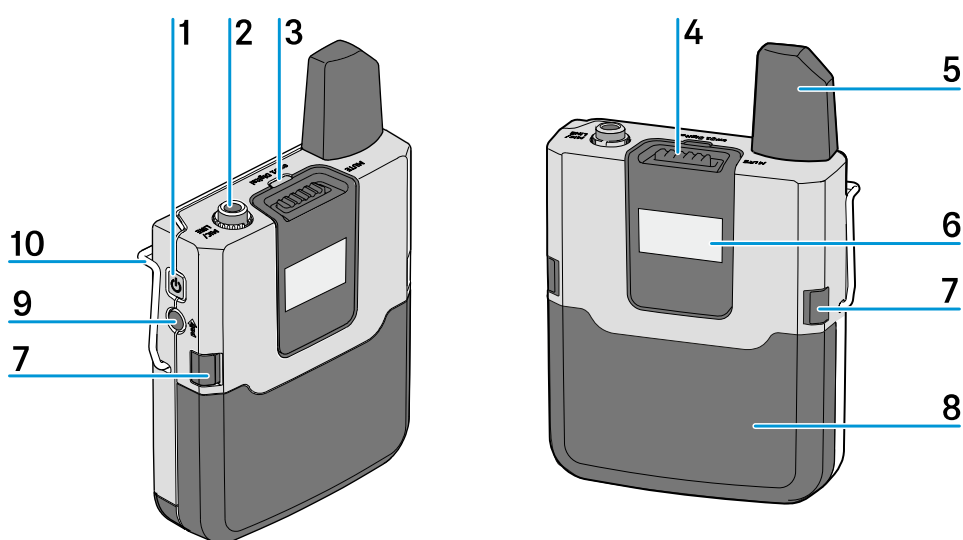

1 ON/OFF button

Short-press to switch the bodypack transmitter on

Long-press to switch the bodypack transmitter off

see [Switching the bodypack transmitter on and off](#)

2 MIC/LINE jack socket (3.5 mm)

for connecting the clip-on or headset microphone

see [Connecting the clip-on microphone or the headset microphone to the bodypack transmitter](#)

3 Status LED

see [Meaning of the status LED](#)

4 MUTE switch

see [MUTE switch](#)

5 Antenna



6 Display panel

see [Displays on the display panel](#)

7 Unlock buttons

for releasing the accupack or the battery compartment

see [Removing/inserting the accupack](#)

8 BA 30 accupack

see [Removing/inserting the accupack](#)

9 PAIR button

Short-press to identify the paired transmitter

Long-press to pair with a different transmitter

see [Pairing](#)

10 Belt clip

You can use the belt clip to attach the bodypack transmitter to clothing (e.g. belt, waistband). The bodypack transmitter should be attached so that the antenna is not covered, otherwise the transmission range will be reduced.

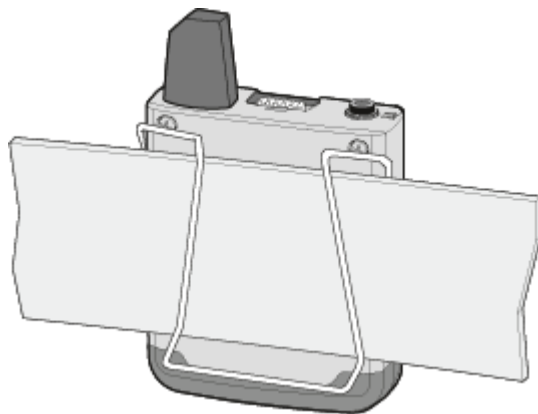



Displays on the display panel

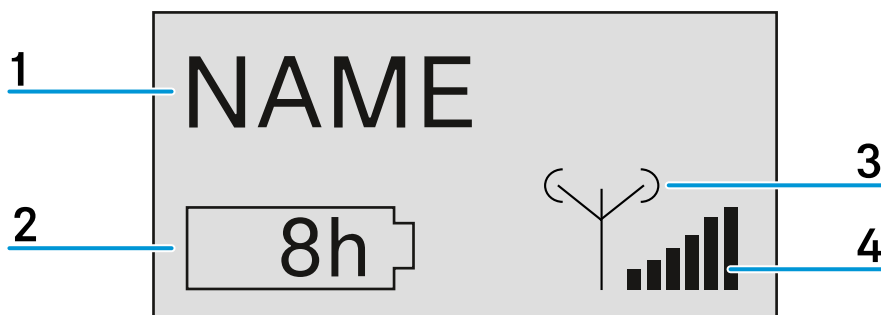

1 Name of the radio link

Can be entered in the Device Identification menu of the receiver (see [Using the operating menu of the receiver](#)).

2 7-step display of the accupack or battery capacity

Graphically displays the current charge status of the accupack or the batteries.

If you use the accupack, the remaining operating time is displayed in hours.

3 RF output power of the transmitter

Displays the RF output power of the handheld transmitter.

4 6-step display for the RF signal level

Displays the current level of the RF signal.



Removing/inserting the accupack

The accupack must be charged before the first use. The accupack can either be charged with the optional CHG 2 or CHG 4N chargers (see [The CHG 2N charger](#) or [The CHG 4N charger](#)) or with the supplied USB cable.

To remove the accupack:

- ▶ Simultaneously press the two unlock buttons and pull the accupack away from the bodypack transmitter.

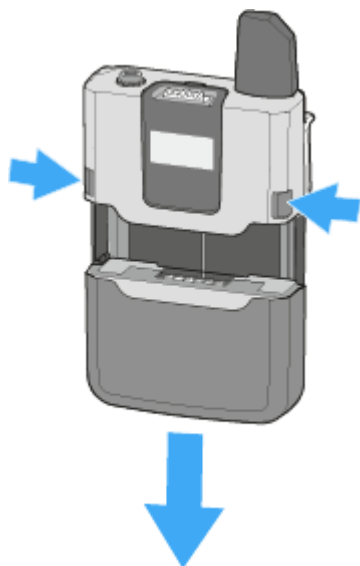



To insert the accupack:

- ▶ Slide the accupack onto the handheld transmitter as shown.
- ✓ The accupack or the battery compartment locks into place with an audible click.

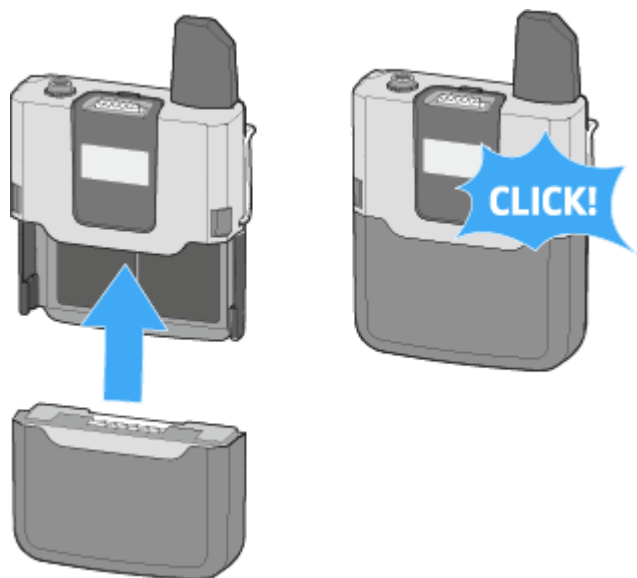



Connecting the clip-on microphone or the headset microphone to the bodypack transmitter

Only connect the clip-on microphone or the headset microphone recommended by Sennheiser. These microphones are optimized for the bodypack transmitter.

- ▶ Connect the jack plug of the clip-on microphone or headset microphone to the 3.5 mm jack socket (MIC/LINE) of the bodypack transmitter.
- ▶ Lock the jack plug by screwing down the coupling ring.

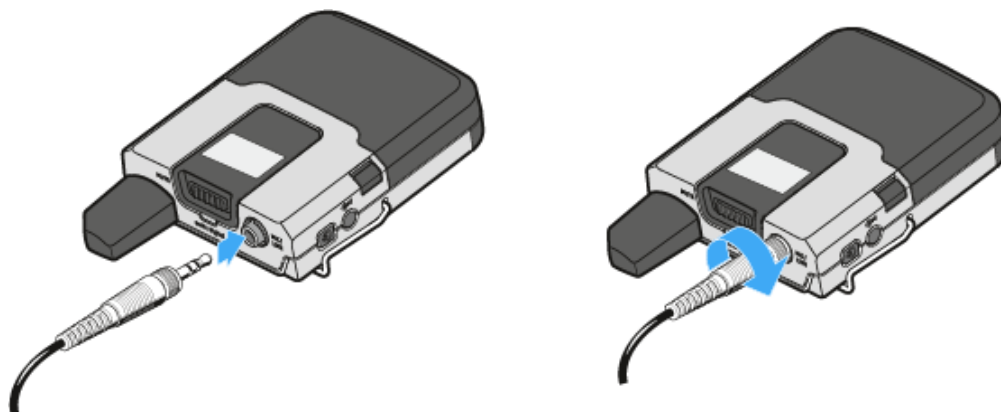

- ✓ When the jack plug is not firmly locked, crackling noise can appear in the audio signal.

i Alternatively, you can use a 3.5 mm jack cable to connect a line source (e.g. a smartphone, tablet or laptop) to the bodypack transmitter.



Switching the bodypack transmitter on and off

- i** After switch-on, the receivers and transmitters will take approx. 10 seconds to establish the radio links.

To switch the handheld transmitter on:

- ▶ Short-press the ON/OFF button.

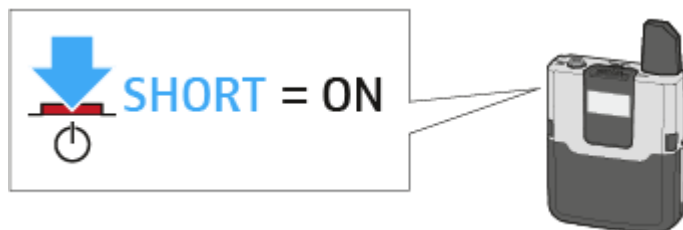

- ✓ The home screen appears on the display panel (see [Displays on the display panel](#)). The status LED indicates the current status of the receiver (see [Meaning of the status LED](#)). The radio link to the last paired receiver is established automatically as soon as the receiver is switched on.

To switch the handheld transmitter off:

- ▶ Press the ON/OFF button for approx. 3 seconds.

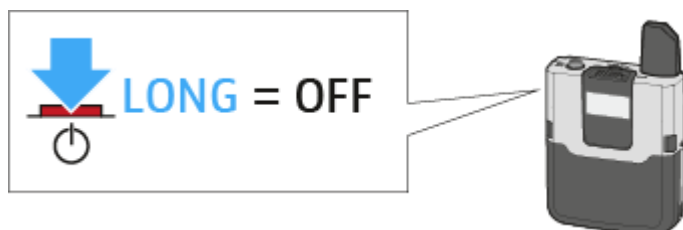

- ✓ The display panel and the status LED go off.



Meaning of the status LED

lights up green

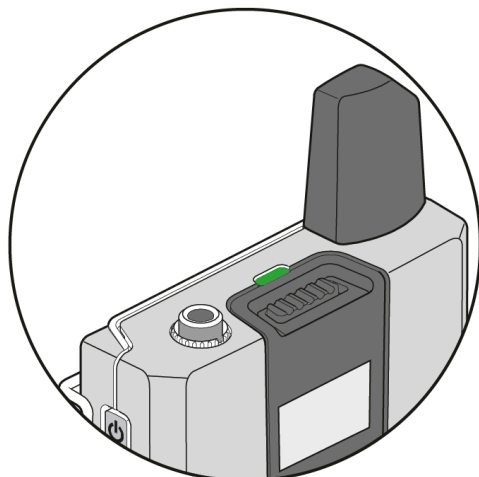

A radio link to the receiver is established.
The accupack of the bodypack transmitter is sufficiently charged.

flashes green

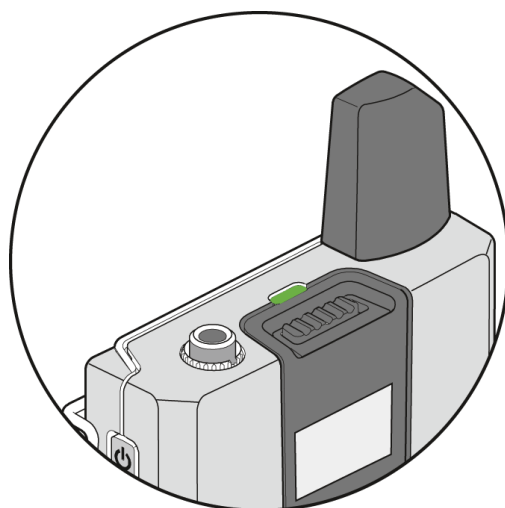

The PAIR button has been short-pressed.
Paired devices are being identified.

flashes alternately green and red

The PAIR button has been long-pressed. The bodypack transmitter establishes a radio link to a receiver whose PAIR button has also been long-pressed.

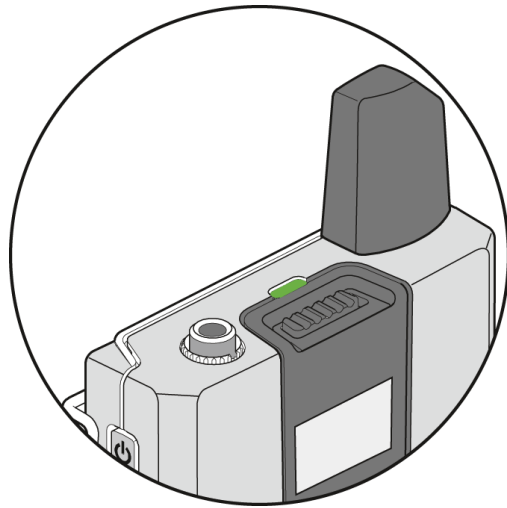

lights up yellow

The bodypack transmitter has been muted with the MUTE switch. In addition, **Muted** is displayed on the display panel.

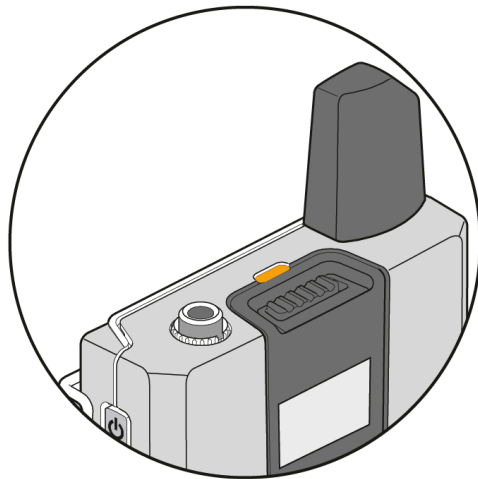

flashes yellow

The firmware is being updated.

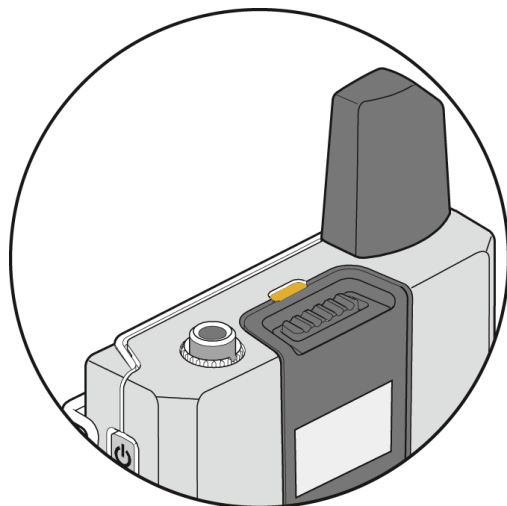



lights up red

No radio link to a receiver. In addition, **No Link** is displayed on the display panel.

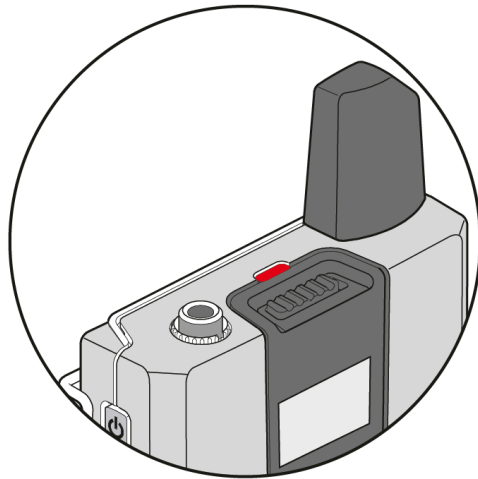

flashes red

The accupack capacity of the bodypack transmitter is only sufficient for max. 30 minutes of operation.

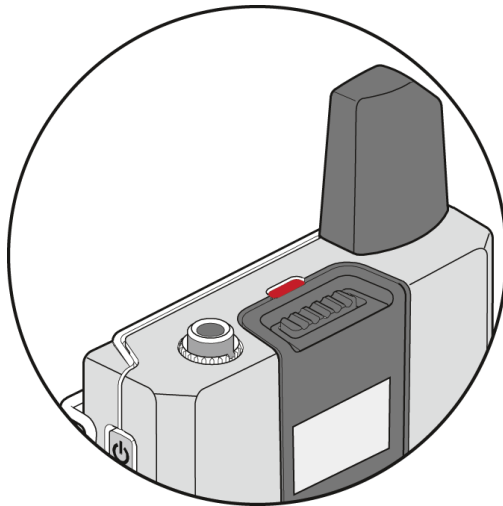



MUTE switch

The bodypack transmitter can be muted with the MUTE switch. This only mutes the audio signal. The radio link remains active and the transmitter remains operational.

The MUTE switch can be deactivated in the System Settings menu of the receiver. With the MUTE switch deactivated, the bodypack transmitter cannot be muted.

To mute the bodypack transmitter:

- ▶ Slide the MUTE switch to the position **MUTE**.
 - ✓ **Muted** appears on the display panel of the receiver. The status LED on both the bodypack transmitter and the receiver lights up yellow.

To cancel the muting:

- ▶ Slide the MUTE switch to the position **MIC**.

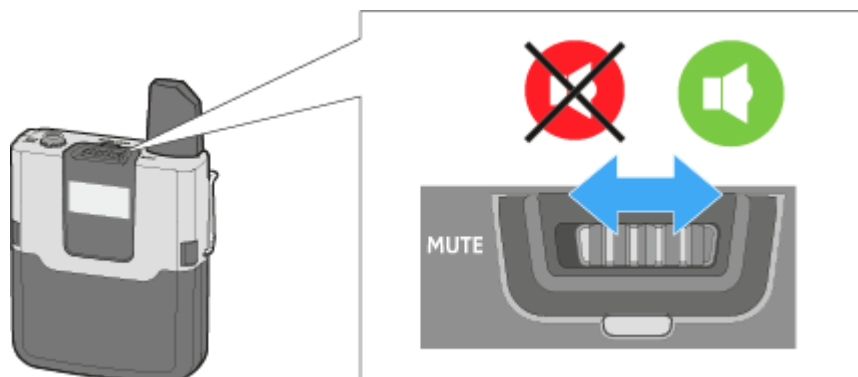



Updating the firmware

The firmware of the receiver and the received transmitter is updated using the **Sennheiser Control Cockpit** software.

You can find more information about this procedure in the software help within the software itself or the **download area** of the Sennheiser website.

[Control Cockpit](#)

sennheiser.com/download

- i** When updating the firmware, make sure that only the transmitter whose firmware is currently being updated is switched on. All other transmitters should be switched off.



The SL Tablestand 133-S DW

The wireless SL Tablestand 133-S DW is designed for your speech. It is compatible with all Sennheiser XLR-3 goose neck microphones, making it ideal for podium discussions, speeches and presentations.

Because it is completely cable free, the SL Tablestand 133-S DW is extremely versatile and suited for a wide range of applications.

The SL Tablestand 133-S DW can be charged either wirelessly or via USB. The CHG 2W wireless charging base for two mobile devices is available separately. The SL Tablestand 133-S DW is delivered with a rechargeable battery that lasts up to 10 hours.

The Sennheiser Control Cockpit software can be used to monitor and control the wireless table stand remotely.

Product overview

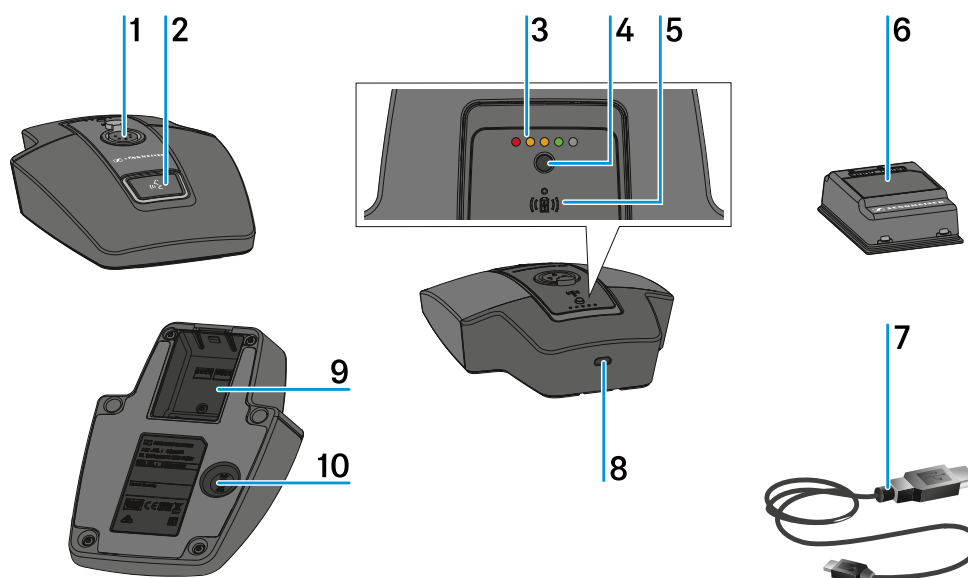

- 1 XLR-3 socket for connecting a goose neck microphone
see [Connecting the goose neck microphone](#)
- 2 ON/OFF button with mute function
see [Switching the table stand on/off](#)
see [Muting the table stand](#)
- 3 Charge level LEDs
see [Meaning of the charge level LEDs on the table stand](#)
- 4 Button for displaying the charge level
see [Meaning of the charge level LEDs on the table stand](#)



5 Alignment LED

Lights up when the SL Tablestand 133-S DW is correctly positioned for charging on the CHG 2W charging base

6 BA 40 accupack

see [Removing/inserting the BA 40 accupack](#)

7 USB cable

see [Charging the table stand](#)

8 Micro-USB socket

see [Charging the table stand](#)

9 Rechargeable battery compartment for BA 40 accupack

see [Removing/inserting the BA 40 accupack](#)

10 PAIR button

Short-press to identify the paired receiver

Long-press to pair with a different receiver

see [Pairing](#)



Removing/inserting the BA 40 accupack

The included BA 40 accupack is used to power the table stand. The accupack must be charged before the first use. The accupack can either be charged with the optional CHG 2W charging base (see [The CHG 2W charging base](#)) or with the supplied USB cable.

To remove the accupack:

- ▶ Pull the unlock button away from the accupack and pull the accupack out of the compartment.

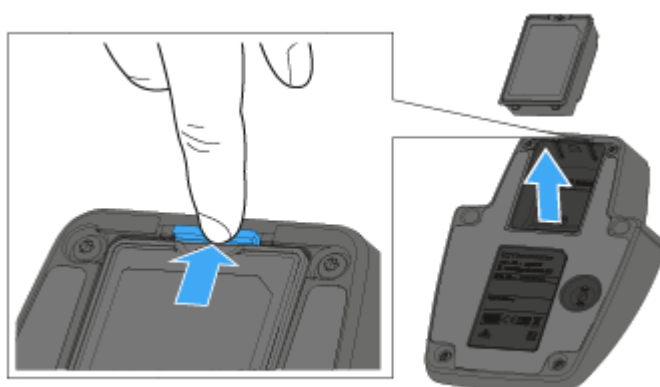

To insert the accupack:

- ▶ Slide the accupack into the compartment with the correct orientation until the unlock button locks into place.

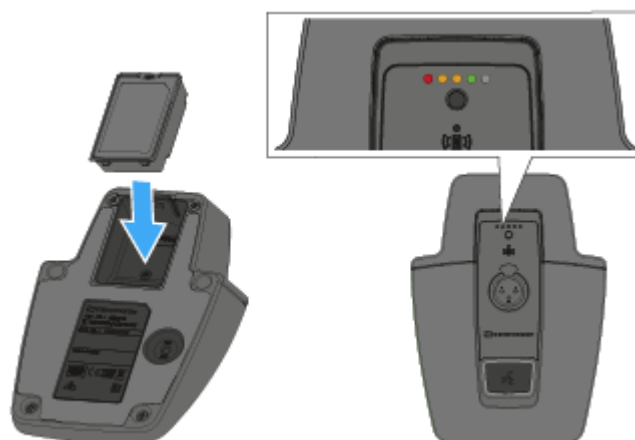

- ✔ The charge level LEDs light up briefly and indicate the charge level.



Charging the table stand

To charge the table stand via USB:

- ▶ Connect the USB cable's Micro-USB plug to the Micro-USB socket of the accupack.

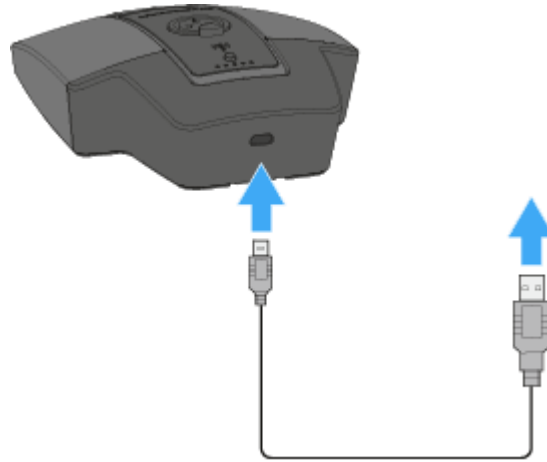

- ▶ Plug the other end of the USB cable into a USB power supply unit.
- ✓ The charge level LEDs indicate the charge level.

To charge the table stand using the CHG 2W charging base:

- ▶ Place the table stand on the CHG 2W charging base in the area marked.

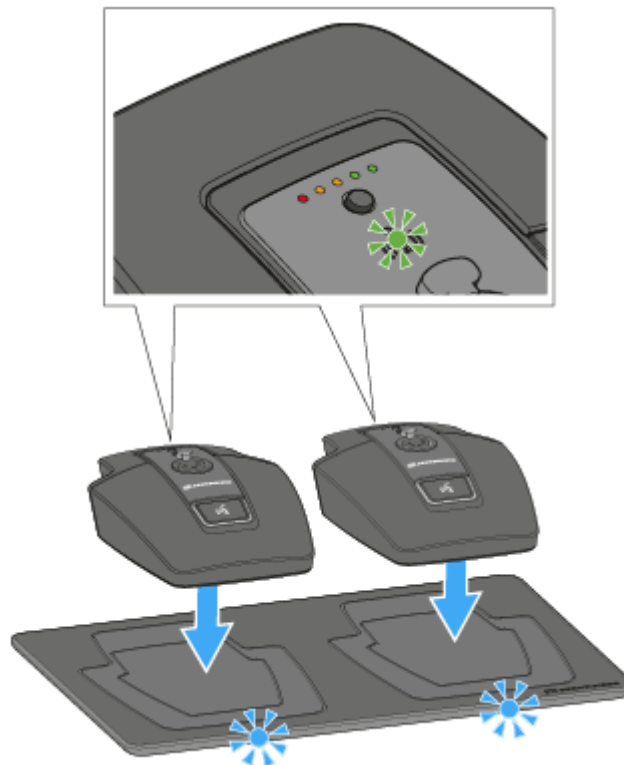



- ✓ If the table stand is positioned correctly on the charging surface, the alignment LED lights up green.

The LEDs on the CHG 2W charging base flash blue during charging.

i You can find more information about the CHG 2W wireless charging base under [The CHG 2W charging base](#).

Charging the table stand with a wireless Qi charging base from a third-party manufacturer

i You can charge the SL Tablestand 133-S DW with any charging base that uses the wireless Qi charging standard.

- ▶ Place the table stand on the third-party Qi charging base.
- ✓ The alignment LED lights up green once the table stand is correctly positioned.







i You can find more information about third-party Qi charging bases in the documentation from the respective manufacturers.



Meaning of the charge level LEDs on the table stand

The charge level LEDs indicate the charge level of the SL Tablestand 133-S DW.

At 100 % charge, the SL Tablestand 133-S DW has an operating time of about 10 hours.

	100 %
	80 %
	60 %
	40 %
	20 %
	 Low Batt



Connecting the goose neck microphone

We recommend using the MEG 14-40 goose neck microphone. This microphone is optimally suited for the table stand.

To connect the goose neck microphone:

- ▶ Plug the goose neck microphone into the XLR-3 socket until it locks into place.

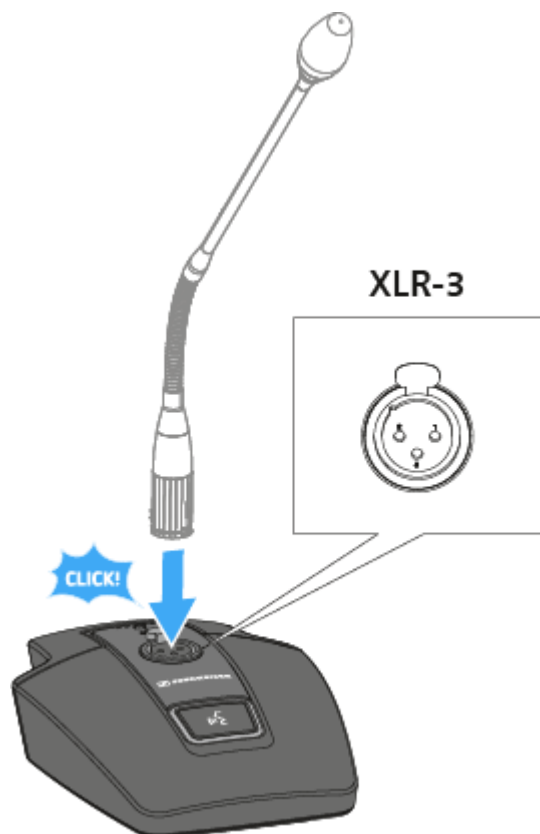



Switching the table stand on/off

To switch the table stand on:

- ▶ Press the **ON/OFF** button for 1 second.

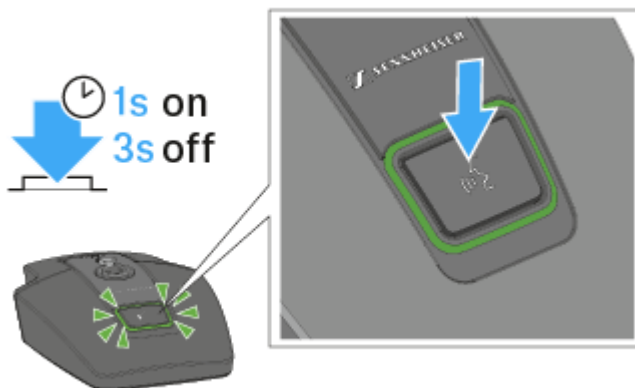

- ✔ The button lights up green when a goose neck microphone is connected.

To switch the table stand off:

- ▶ Press the **ON/OFF** button for 3 seconds.



Muting the table stand

To mute the table stand:

- ▶ While the table stand is switched on and a goose neck microphone is connected, press the **ON/OFF** button for 1 second.

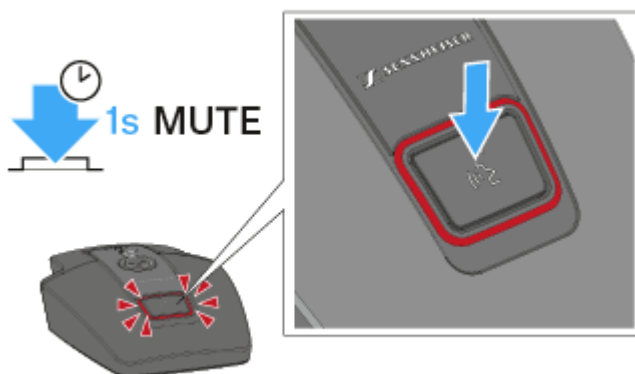

- ✓ The button lights up red.

In Push to talk mode, the audio signal is muted by default and is only activated while the **ON/OFF** button is pressed.

In Push to mute mode, the audio signal is active by default and is only muted while the **ON/OFF** button is pressed.

You can set the mute mode in the menu of the SL Rack Receiver DW or using the Sennheiser Control Cockpit.



Updating the firmware

The firmware of the receiver and the received transmitter is updated using the **Sennheiser Control Cockpit** software.

You can find more information about this procedure in the software help within the software itself or the **download area** of the Sennheiser website.

[Control Cockpit](#)

sennheiser.com/download

- i** When updating the firmware, make sure that only the transmitter whose firmware is currently being updated is switched on. All other transmitters should be switched off.



The SL Tablestand 153-S DW

The wireless SL Tablestand 153-S DW is designed for your speech. It is equipped with an XLR-5 socket to provide a hardwired connection to the MEG 14-40-L-II B goose neck microphone.

Because it is completely wireless, the SL Tablestand 153-DW is the perfect solution for ad hoc press conferences or panel discussions in any environment.

The SL Tablestand 153-S DW can be charged either wirelessly or via USB. The CHG 2W wireless charging base for two mobile devices is available separately. The SL Tablestand 153-S DW is equipped with dedicated charging status LEDs to clearly show the battery life.

The Sennheiser Control Cockpit software can be used to monitor and control the SL Tablestand 153-S DW remotely.

Product overview

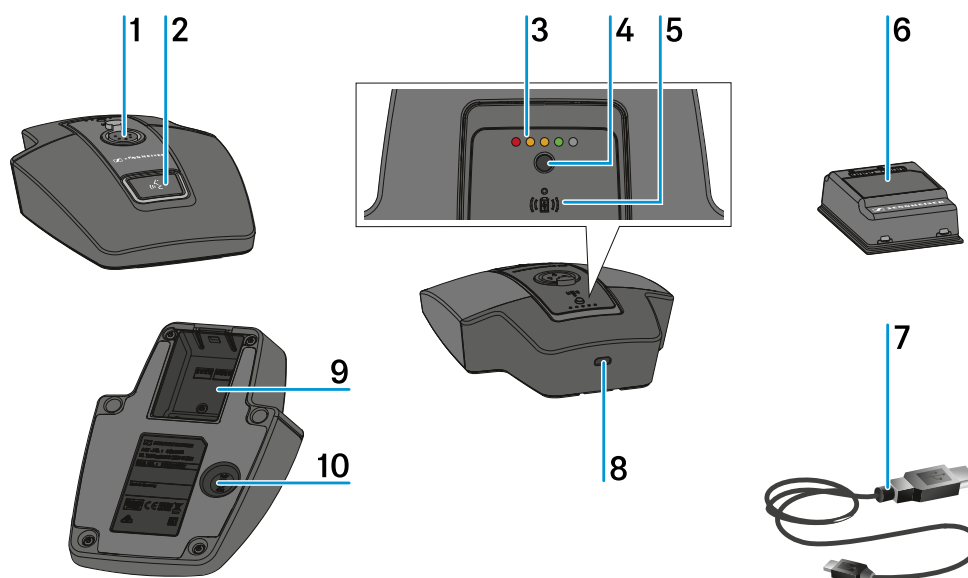

- 1 XLR-5 socket for connecting a goose neck microphone
see [Connecting the goose neck microphone](#)
- 2 ON/OFF button with mute function
see [Switching the table stand on/off](#)
see [Muting the table stand](#)
- 3 Charge level LEDs
see [Meaning of the charge level LEDs on the table stand](#)
- 4 Button for displaying the charge level
see [Meaning of the charge level LEDs on the table stand](#)



5 Alignment LED

Lights up when the SL Tablestand 153-S DW is correctly positioned for charging on the CHG 2W charging base

6 BA 40 accupack

see [Removing/inserting the BA 40 accupack](#)

7 USB cable

see [Charging the table stand](#)

8 Micro-USB socket

see [Charging the table stand](#)

9 Rechargeable battery compartment for BA 40 accupack

see [Removing/inserting the BA 40 accupack](#)

10 PAIR button

Short-press to identify the paired receiver

Long-press to pair with a different receiver

see [Pairing](#)



Removing/inserting the BA 40 accupack

The included BA 40 accupack is used to power the table stand. The accupack must be charged before the first use. The accupack can either be charged with the optional CHG 2W charging base (see [The CHG 2W charging base](#)) or with the supplied USB cable.

To remove the accupack:

- ▶ Pull the unlock button away from the accupack and pull the accupack out of the compartment.

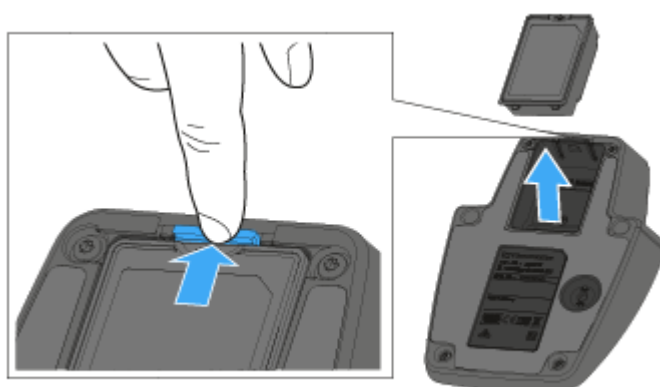

To insert the accupack:

- ▶ Slide the accupack into the compartment with the correct orientation until the unlock button locks into place.

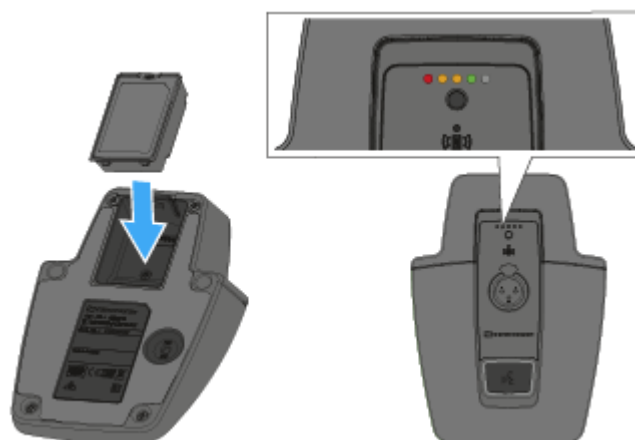

- ✔ The charge level LEDs light up briefly and indicate the charge level.



Charging the table stand

To charge the table stand via USB:

- ▶ Connect the USB cable's Micro-USB plug to the Micro-USB socket of the accupack.

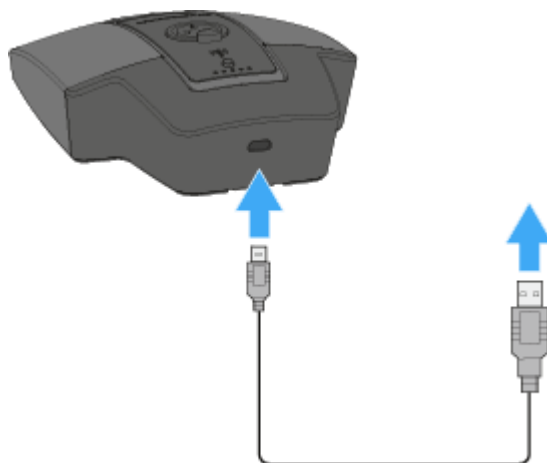

- ▶ Plug the other end of the USB cable into a USB power supply unit.
- ✓ The charge level LEDs indicate the charge level.

To charge the table stand using the CHG 2W charging base:

- ▶ Place the table stand on the CHG 2W charging base in the area marked.

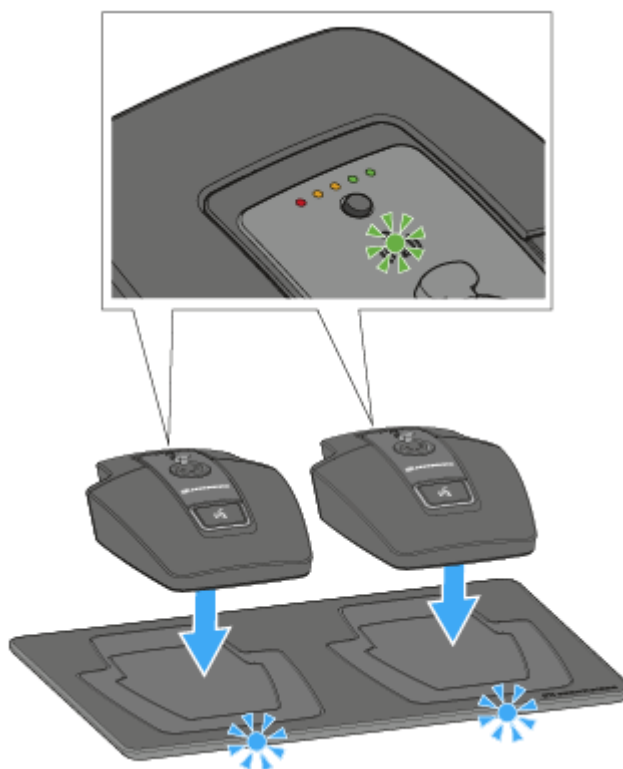



- ✓ If the table stand is positioned correctly on the charging surface, the alignment LED lights up green.

The LEDs on the CHG 2W charging base flash blue during charging.

i You can find more information about the CHG 2W wireless charging base under [The CHG 2W charging base](#).

Charging the table stand with a wireless Qi charging base from a third-party manufacturer

i You can charge the SL Tablestand 133-S DW with any charging base that uses the wireless Qi charging standard.

- ▶ Place the table stand on the third-party Qi charging base.
- ✓ The alignment LED lights up green once the table stand is correctly positioned.







i You can find more information about third-party Qi charging bases in the documentation from the respective manufacturers.



Meaning of the charge level LEDs on the table stand

The charge level LEDs indicate the charge level of the SL Tablestand 133-S DW.

At 100 % charge, the SL Tablestand 133-S DW has an operating time of about 10 hours.

	100 %
	80 %
	60 %
	40 %
	20 %
	 Low Batt



Connecting the goose neck microphone

We recommend using the MEG 14-40-L-II goose neck microphone. This microphone is optimally suited for the table stand.

To connect the goose neck microphone:

- ▶ Plug the goose neck microphone into the XLR-5 socket until it locks into place.

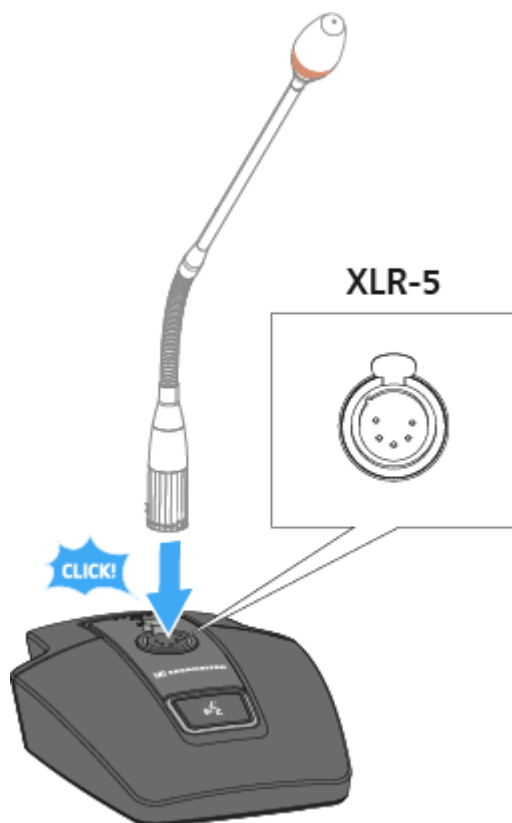



Switching the table stand on/off

To switch the table stand on:

- ▶ Press the **ON/OFF** button for 1 second.

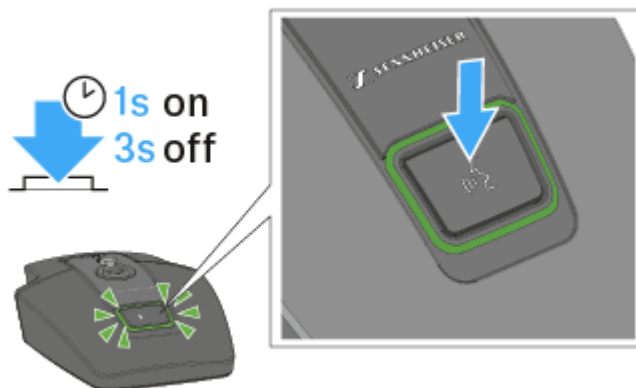

- ✔ The button lights up green when a goose neck microphone is connected.

To switch the table stand off:

- ▶ Press the **ON/OFF** button for 3 seconds.



Muting the table stand

To mute the table stand:

- ▶ While the table stand is switched on and a goose neck microphone is connected, press the **ON/OFF** button for 1 second.

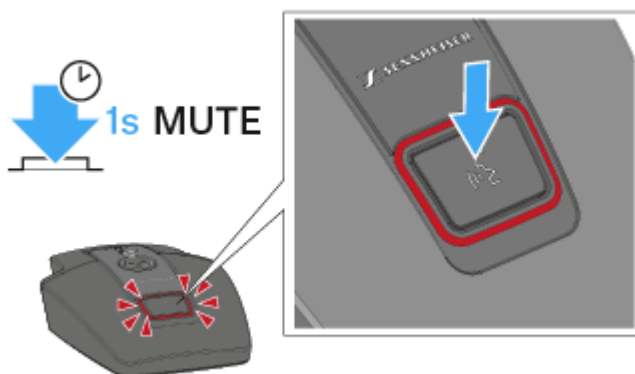

- ✓ The button lights up red.

↳ Push to talk mode, the audio signal is muted by default and is only activated while the **ON/OFF** button is pressed.

↳ Push to mute mode, the audio signal is active by default and is only muted while the **ON/OFF** button is pressed.

You can set the mute mode in the menu of the SL Rack Receiver DW or using the Sennheiser Control Cockpit.



Updating the firmware

The firmware of the receiver and the received transmitter is updated using the **Sennheiser Control Cockpit** software.

You can find more information about this procedure in the software help within the software itself or the **download area** of the Sennheiser website.

[Control Cockpit](#)

sennheiser.com/download

- i** When updating the firmware, make sure that only the transmitter whose firmware is currently being updated is switched on. All other transmitters should be switched off.



The SL Boundary 114-S DW

The wireless SL Boundary 114-S DW boundary microphone is designed for your speech.

Because it is completely cable free, the SL Boundary 114-S DW is extremely versatile and suited for a wide range of applications.

The SL Boundary 114-S DW can be charged either wirelessly or via USB. The CHG 2W wireless charging base for two mobile devices is available separately. The SL Boundary 114-S DW is delivered with a rechargeable battery that lasts up to 10 hours.

The Sennheiser Control Cockpit software can be used to monitor and control the wireless boundary microphone remotely.

Product overview

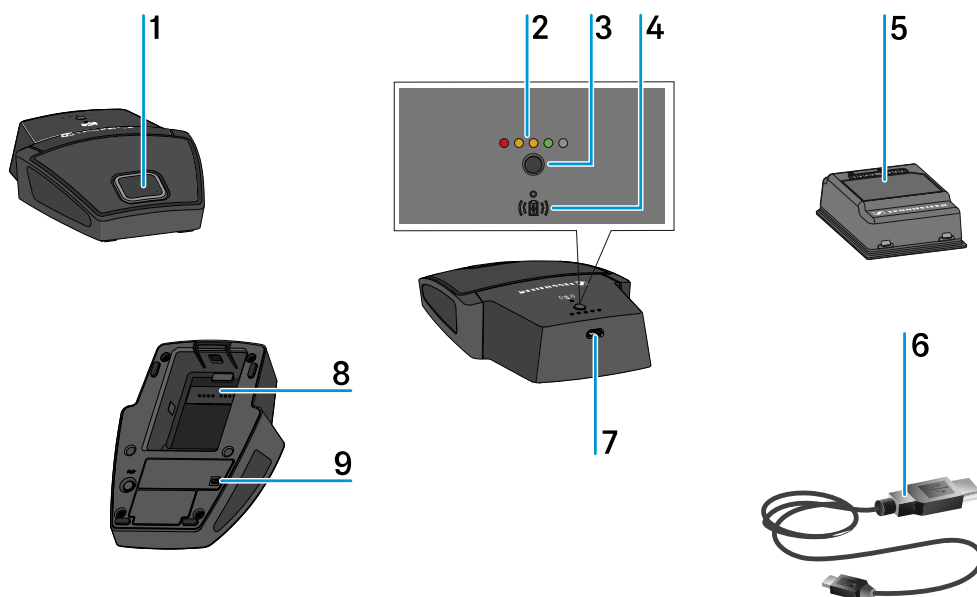

1 ON/OFF button with mute function

see [Switching the boundary microphone on/off](#)

2 Charge level LEDs

see [Meaning of the charge level LEDs](#)

3 Button for displaying the charge level

see [Meaning of the charge level LEDs](#)

4 Alignment LED

Lights up when the SL Boundary 114-S DW is correctly positioned for charging on the CHG 2W charging base

5 BA 40 accupack

see [Removing/inserting the BA 40 accupack](#)



6 USB cable

see [Charging the boundary microphone](#)

7 Micro-USB-socket

see [Charging the boundary microphone](#)

8 Rechargeable battery compartment for BA 40 accupack

see [Removing/inserting the BA 40 accupack](#)

9 PAIR button

Short-press to identify the paired receiver

Long-press to pair with a different receiver

see [Pairing](#)



Removing/inserting the BA 40 accupack

The included BA 40 accupack is used to power the boundary microphone. The accupack must be charged before the first use. The accupack can either be charged with the optional CHG 2W charging base (see [The CHG 2W charging base](#)) or with the supplied USB cable.

To remove the accupack:

- ▶ Pull the unlock button away from the accupack and pull the accupack out of the compartment.

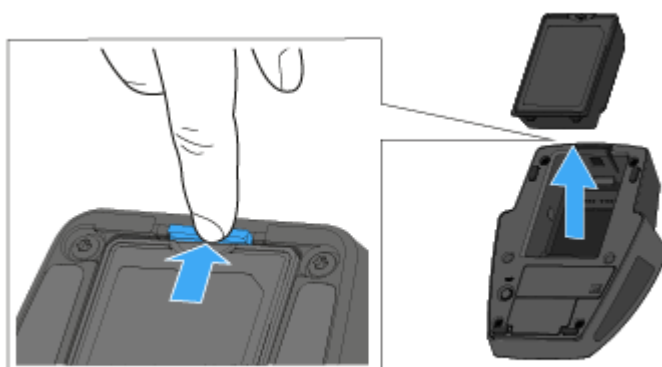

To insert the accupack:

- ▶ Slide the accupack into the compartment with the correct orientation until the unlock button locks into place.

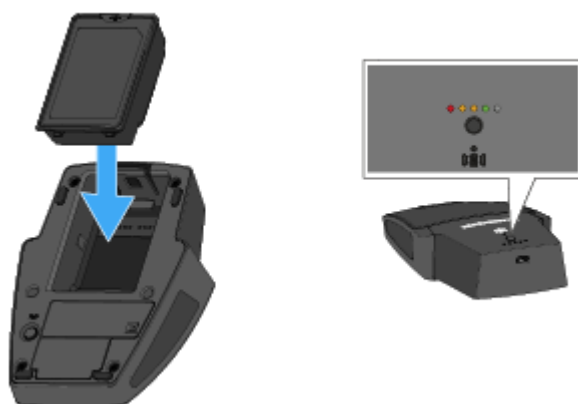

- ✔ The charge level LEDs light up briefly and indicate the charge level.



Charging the boundary microphone

To charge the boundary microphone via USB:

- ▶ Connect the USB cable's Micro-USB plug to the Micro-USB socket of the boundary microphone.
- ▶ Plug the other end of the USB cable into a USB power supply unit.

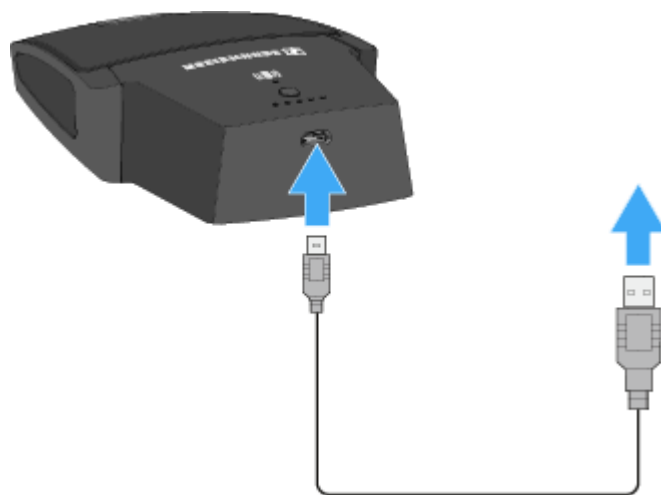

- ✓ The charge level LEDs indicate the charge level.



To charge the boundary microphone using the CHG 2W charging base:

- ▶ Place the boundary microphone on the CHG 2W charging base in the area marked.

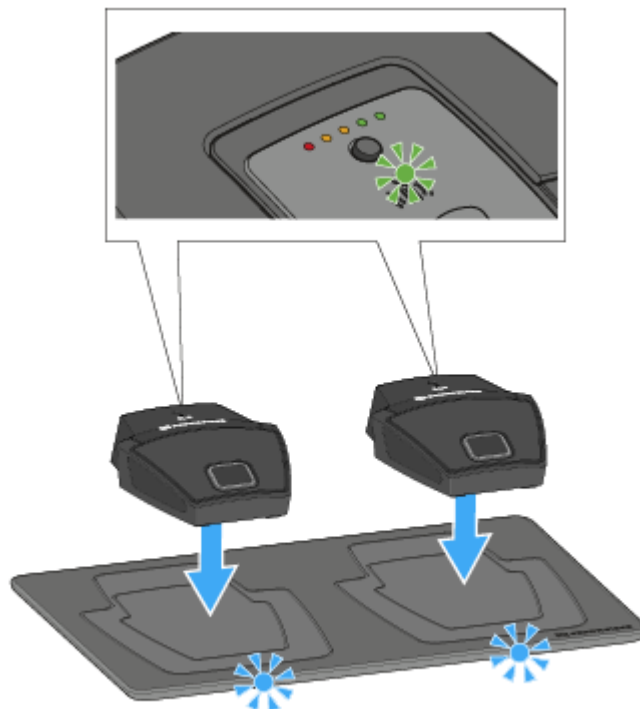

- ✓ If the boundary microphone is positioned correctly on the charging surface, the alignment LED lights up green.

The LEDs on the CHG 2W charging base flash blue during charging.

i You can find more information about the CHG 2W wireless charging base under [The CHG 2W charging base](#).



Charging the boundary microphone with a wireless Qi charging base from a third-party manufacturer

i You can charge the SL Boundary 114-S DW with any charging base that uses the wireless Qi charging standard.

- ▶ Place the boundary microphone on the third-party Qi charging base.
- ✓ The alignment LED lights up green once the table stand is correctly positioned.







i You can find more information about third-party Qi charging bases in the documentation from the respective manufacturers.



Meaning of the charge level LEDs

The charge level LEDs indicate the charge level of the SL Boundary 114-S DW.

At 100 % charge, the SL Boundary 114-S DW has an operating time of about 10 hours.

	100 %
	80 %
	60 %
	40 %
	20 %
	 Low Batt



Switching the boundary microphone on/off

To switch the boundary microphone on:

- ▶ Press the **ON/OFF** button for 1 second.



To switch the boundary microphone off:

- ▶ Press the **ON/OFF** button for 3 seconds.



Muting the boundary microphone

To mute the boundary microphone:

- ▶ If the boundary microphone is on, press the ON/OFF button for 1 second.



- ✓ The button lights up red.

In Push to talk mode, the audio signal is muted by default and is only activated while the **ON/OFF** button is pressed.

In Push to mute mode, the audio signal is active by default and is only muted while the **ON/OFF** button is pressed.

You can set the mute mode in the menu of the SL Rack Receiver DW or using the Sennheiser Control Cockpit.



Updating the firmware

The firmware of the receiver and the received transmitter is updated using the **Sennheiser Control Cockpit** software.

You can find more information about this procedure in the software help within the software itself or the **download area** of the Sennheiser website.

[Control Cockpit](#)

sennheiser.com/download

- i** When updating the firmware, make sure that only the transmitter whose firmware is currently being updated is switched on. All other transmitters should be switched off.



Pairing

The **Pairing** function enables you to identify devices that have already been paired or connect new devices.

Identifying paired devices

You can perform a pairing identification to see which transmitter is paired with which receiver.

With the **SL Rack Receiver DW**, you can perform pairing identification on the **device** or in the **Control Cockpit**.

With the **SL MCR DW**, you can only perform the pairing identification in the **Control Cockpit**.

The SL Rack Receiver DW

- ▶ Short-press the PAIR button of the receiver or of the transmitter.
Or
- ▶ Press the **Find** button of the desired device from the **device list** in the **Control Cockpit**.

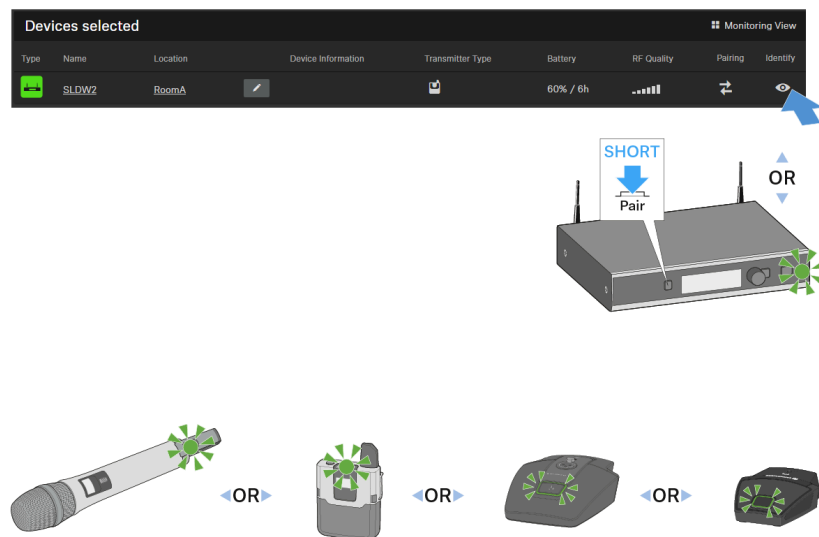

- **Identify** appears on the display panel of the receiver.
- The message **This is** Name appears on the transmitter's display (only SL Handheld DW and SL Bodypack DW).
- The status LEDs of the paired devices flash green for 10 seconds.
- The device's icon in the **Control Cockpit** flashes for 10 seconds.
- The display returns to the standard display after 10 seconds.



SL MCR DW

- ▶ Press the **Find** button of the desired channel of the desired device from the **device list** in the **Control Cockpit**.

Type	Name	Location	Device Information	Transmitter Type	Battery	RF Quality	Pairing	Identify
MCR	IBA							
1	rx1				100%	Full		Find
2	rx2			-	-	Low		Find
3	rx3			-	-	Low		Find
4	rx4			-	-	Low		Find



- The message **This is** Name appears on the transmitter's display (only SL Handheld DW and SL Bodypack DW).
- The status LEDs for the relevant channel will flash green for 10 seconds on the SL MCR DW and the paired transmitter.
- The device's icon in the **Control Cockpit** flashes for 10 seconds.



Pairing a receiver with a transmitter

To establish a new radio link between a receiver and a transmitter, proceed as follows:

The SL Rack Receiver DW

- ▶ Long-press the PAIR button of the receiver until its status LED flashes alternately green and red.
Or
- ▶ Press the **Pair** button of the desired device from the **device list** in the **Control Cockpit**.

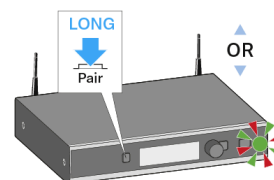
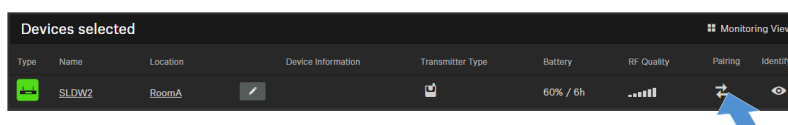

- ✓ First **Identify** appears on the display panel of the receiver. The **Pairing** message then appears.

Any existing radio link is now disconnected.

You now have 90 seconds to establish a radio link with a new transmitter.

- ▶ Long-press the PAIR button of the corresponding transmitter until its status LED flashes alternately green and red.
- ✓ The **Press pair on receiver** message appears on the display panel of the transmitter (SL Handheld DW and SL Bodypack DW only).



Once the radio link is successfully established, **Paired** appears on the display panel of both the receiver and the transmitter (only for SL Handheld DW and SL Bodypack DW) and the status LEDs on the transmitter and the receiver light up green.



If no radio link was successfully established, **Pairing failed** appears on the display panel of both the receiver and the transmitter (only for



SL Handheld DW and SL Bodypack DW) and the status LEDs on the transmitter and the receiver light up red.

i If you try to pair devices that are running incompatible firmware versions, a message appears on the display panel prompting you to update the firmware of the transmitter.

Wenn If you update the firmware now, the transmitter and the receiver will be paired afterwards

If you do not update the firmware, the transmitter and the receiver will not be paired and FW mismatch appears on the display panel of the receiver.

We recommend updating the receiver firmware first and then the transmitter firmware.

When updating the firmware, make sure that only the transmitter whose firmware is currently being updated is switched on. All other transmitters should be switched off.

SL MCR DW

- ▶ Press the **Pair** button of the desired device from the **device list** in the **Control Cockpit**.

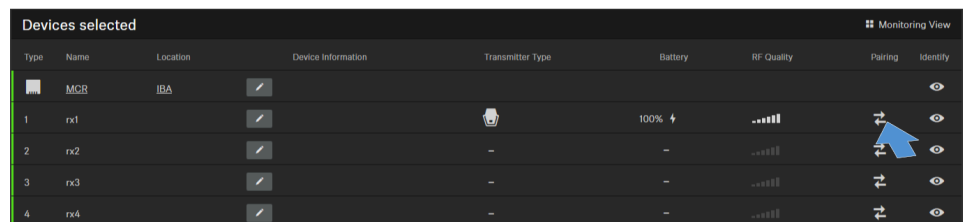

- ✓ First, **Identify** appears on the display panel of the receiver. The **Pairing** message then appears.

Any existing radio link is now disconnected.

You now have 90 seconds to establish a radio link with a new transmitter.

- ▶ Long-press the PAIR button of the corresponding transmitter until its status LED flashes alternately green and red.
- ✓ The **Press pair on receiver** message appears on the display panel of the transmitter (SL Handheld DW and SL Bodypack DW only).



Once the radio link is successfully established, **Paired** appears on the display panel of the transmitter (only for SL Handheld DW and SL Bodypack DW) and the status LEDs of the transmitter and the receiving channel light up green.



If no radio link was successfully established, **Pairing failed** appears on the display panel of the transmitter (only for SL Handheld DW and SL Bodypack DW) and the status LEDs of the transmitter and the receiving channel light up red.

i If you try to pair devices that are running incompatible **firmware** versions, a message appears in the Control Cockpit prompting you to update the firmware of the transmitter.

If you update the firmware now, the transmitter and the receiving channel will be paired afterwards.

If you do not update the firmware, the transmitter and the receiving channel will not be paired.

We recommend updating the receiver firmware first and then the transmitter firmware.

When updating the firmware, make sure that only the transmitter whose firmware is currently being updated is switched on. All other transmitters should be switched off.



Performing a walk test (reception quality)

The **Walk Test** menu item allows you to check the reception quality of your radio links within the operating environment. By performing a walk test, you can verify the range and coverage of the radio link.

Performing a walk test with the SL MCR DW in the Control Cockpit

To perform a walk test in the Control Cockpit:

- ▶ Switch on the transmitter and the receiver of the radio link you want to check.
- ▶ In addition, switch on all other devices that you want to use in the operating environment.
- ▶ Select the device in the **Control Cockpit**.
- ▶ Open the **RF settings** tab.

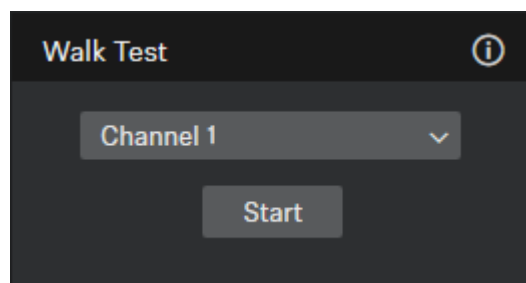

- ▶ Select the desired channel under **Walk Test** and click **Start**.

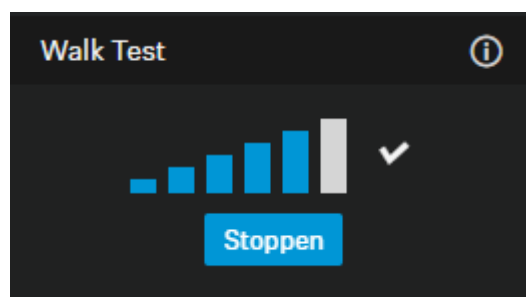

- ▶ Walk the operating environment with the transmitter.
 - ✓ The display of the radio signal level is continuously updated.
- ▶ Click **Stop** to end the walk test.



If the result of the walk test is not satisfying, you can take the following remedial measures:

- If possible, position the receiver so that there is always a direct line of sight between the receiver and the paired transmitter.
- If possible, remove obstacles between the transmitter and the receiver.
- If necessary, adjust the manually selected transmission power in the **Control Cockpit** under **RF power mode** on the **RF settings** tab. You can find more information under [Multi-room mode](#).



Performing a walk test with the SL Rack Receiver DW in the Control Cockpit

To perform a walk test in the Control Cockpit:

- ▶ Switch on the transmitter and the receiver of the radio link you want to check.
- ▶ In addition, switch on all other devices that you want to use in the operating environment.
- ▶ Select the device in the **Control Cockpit**.
- ▶ Open the **RF settings** tab.

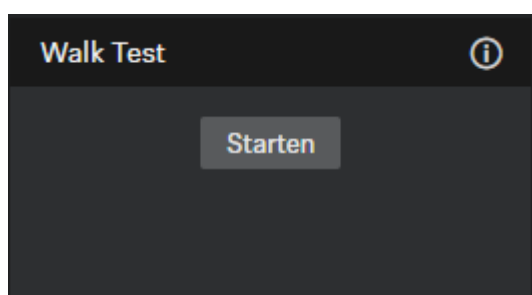

- ▶ Click **Start** under **Walk Test**.

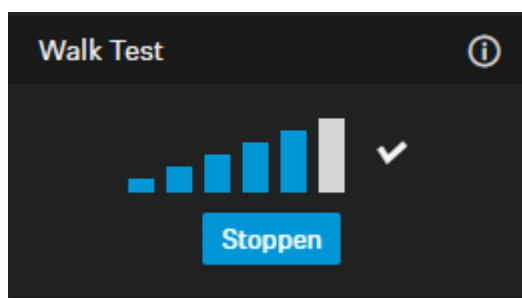

- ▶ Walk the operating environment with the transmitter.
 - ✓ The display of the radio signal level is continuously updated.
- ▶ Click **Stop** to end the walk test.

If the result of the walk test is not satisfying, you can take the following remedial measures:

- If possible, position the receiver so that there is always a direct line of sight between the antennas (directly on the receiver or remotely mounted) and the paired transmitter.
- If possible, remove obstacles between the transmitter and the antennas.
- Pay attention to the notes about antenna installation: [Recommendations on antenna mounting](#).
- If necessary, adjust the manually selected transmission power in the **Control Cockpit** under **RF power mode** on the **RF settings** tab. You can find more information under [Multi-room mode](#).



Performing a walk test with the SL Rack Receiver DW on the device

To perform a walk test on the device:

- ▶ Switch on the transmitter and the receiver of the radio link you want to check.
- ▶ In addition, switch on all other devices that you want to use in the operating environment.
- ▶ From the receiver's **System Settings** menu, select the **Walk Test** menu item.
 - ✓ The RF signal level display appears on the display panel of both the receiver and the transmitter.



- ▶ Walk the operating environment with the transmitter.
 - ✓ The RF signal level display on the display panel of both the receiver and the transmitter is continuously updated.
- ▶ Check the RF signal level display for more detailed information on the reception quality:



Good reception quality is indicated by a tick.

If the tick is missing, reception quality is sufficient.



If reception quality is or was compromised at any position, this is indicated by a warning triangle.

The warning triangle remains displayed on the display panel even if reception quality improves afterwards.

NO LINK

If the radio link breaks down completely, the background of the display panel changes back and forth between light and dark and **No Link** appears on the display panel.

- ▶ Press the ESC button on the receiver to end the walk test.



If the result of the walk test is not satisfying, you can take the following remedial measures:

- If possible, reposition the receivers so that there is always a direct line of sight between the receiver antennas and the paired transmitter.
- If possible, remove obstacles between the transmitter and the receiving antennas.
- When rack mounting receivers, you should mount their rod antenna to the front of the rack using the GA 4 rack-mount kit.
- If you have manually adjusted the transmission power, you may have to readjust it via the receiver's operating menu: **System Settings -> RF Power**. You can find more information under [Multi-room mode](#).



The Headmic 1 headset microphone

The Headmic 1 is a high-quality omni-directional condenser headset microphone designed for professional “hands free” applications. Its adjustable neckband is visually unobtrusive and very comfortable to wear. The Headmic 1 is available in black and beige. The pick-up pattern is omni-directional.

Preparing the headset microphone for use

To connect the cable to the headset microphone:

- ▶ Plug the connector into the socket.

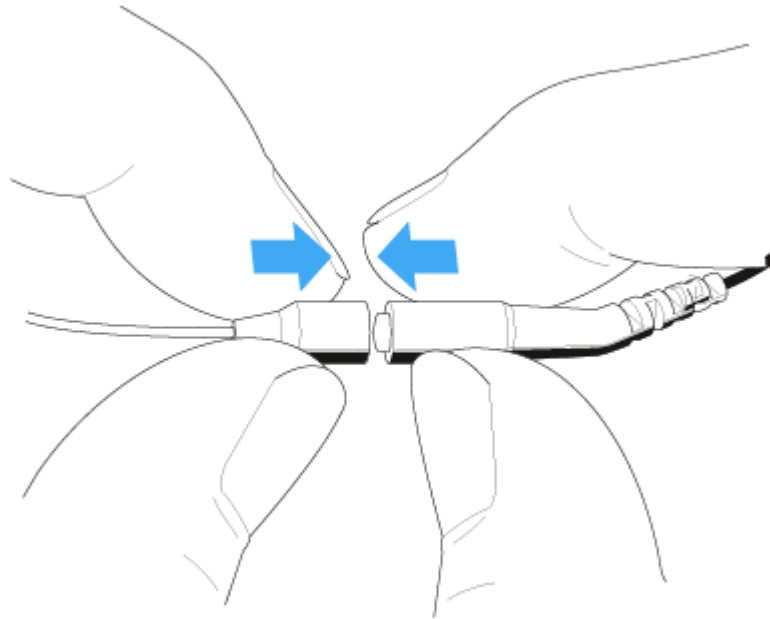

- ▶ Slide the silicone tube onto the connector.

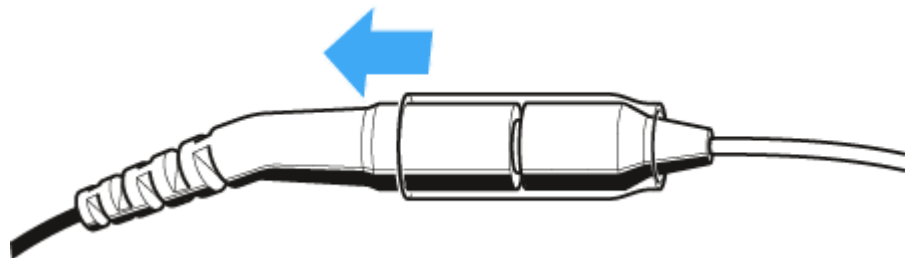



Changing the microphone position (left/right)

You can wear the microphone on either the left or right side.



The neckband has a total of five clips which are designed so that the microphone boom can be worn on either side of the mouth.

NOTICE



Damage to the microphone boom

The microphone boom can break or be impaired in its function when you bend or turn it. Frequent alternate bendings close to the microphone capsule can also damage the microphone boom and possibly reduce the adjustability of the microphone.

- ▶ Only adjust the microphone boom as described in this chapter.

To remove the microphone boom:

- ▶ First remove the microphone boom from the two clips 1 and 2.
- ▶ Turn the microphone boom to remove it from the third clip 3.

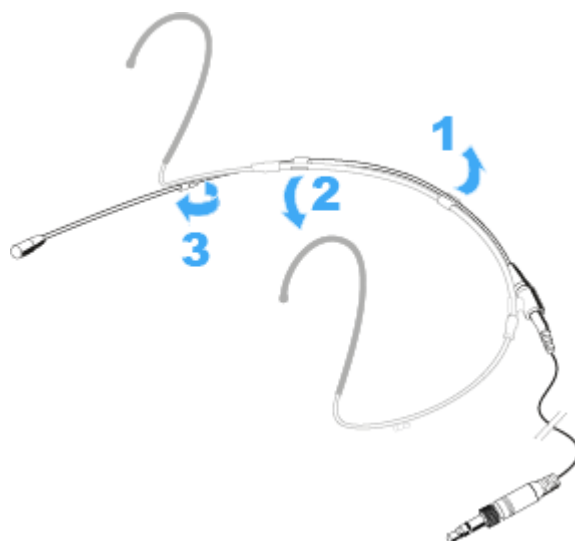



To reattach the microphone boom:

- ▶ First attach the end of the microphone boom where the microphone capsule is fitted to the clip 5 on the desired side of the neckband.

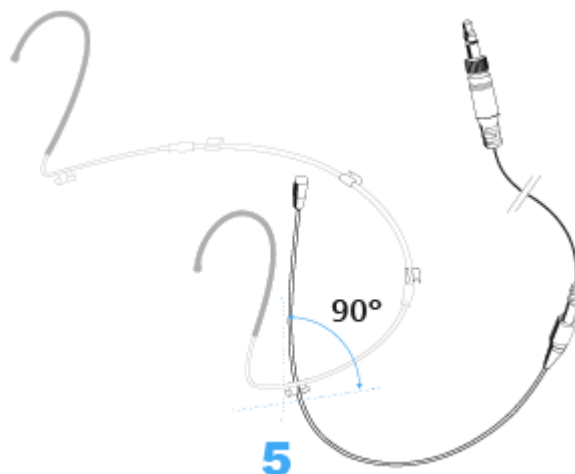

- ▶ Press the microphone boom into the two clips 3 and 4.

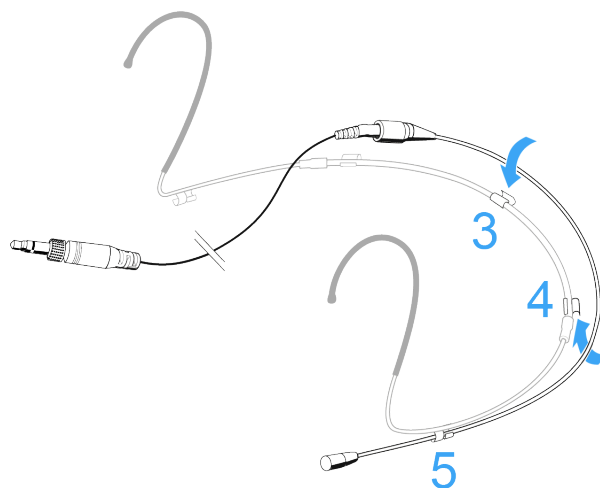



Adjusting the microphone boom and the neckband

For best possible comfort and optimum fit of the headset microphone, the neckband padding and the microphone boom have to be adjusted to properly fit your head.

NOTICE



Damage to the microphone boom

The microphone boom can break or be impaired in its function when you bend or turn it.

- ▶ Only adjust the microphone boom as described in this chapter.

To individually position the microphone:

- ▶ Slide the microphone boom forward or backward in the clips so that the microphone is 2 to 3 cm from the corner of your mouth.

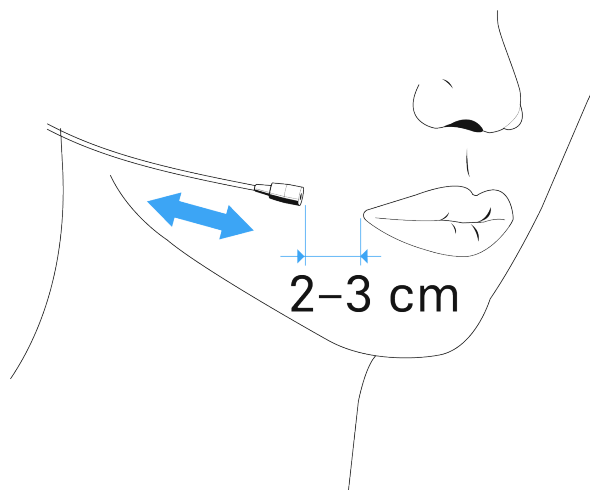

- ✓ The further away the microphone is from the mouth, the less treble is picked up.



Adjusting the neckband

i The neckband is adjustable in width and ensures an optimum fit.

- ▶ Change the length of the neckband by moving the ear hooks until a snug but comfortable fit is achieved.

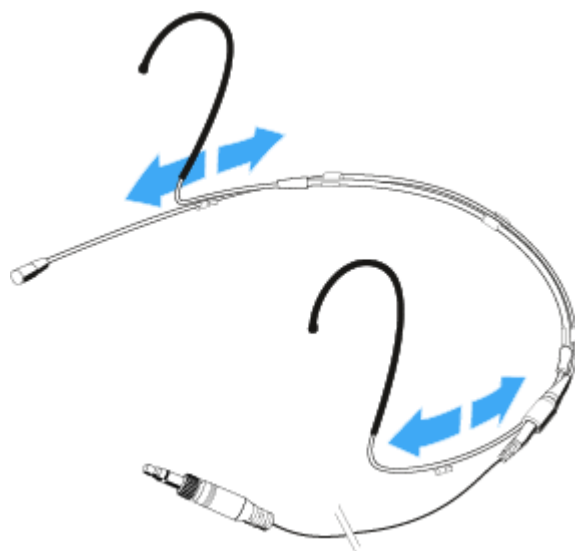



Using the frequency response caps

The MZC 2 frequency response cap enables you to change the sensitivity of the microphone in the presence range. The MZC 2 gives a treble boost of 4 dB. Use this cap if the microphone cannot be positioned close to the mouth, if the sound is too muffled or if you want to increase the speech intelligibility.

- ▶ Slide the MZC 2 frequency response cap over the microphone capsule until you hear it click into place.



i An additional frequency response cap (MZC 1) is available as an accessory. The MZC 1 ensures a treble boost of 2 dB.

- ▶ Slide the MZC 1 frequency response cap over the microphone capsule until you hear it click into place.





Using the windshield

The SL MZW 1 windshield reduces wind noise by 10 dB.

- ▶ Slide the SL MZW 1 windshield over the MZC 2 frequency response cap.





Attaching the connection cable to clothing

The MZQ 02 clip is available as an accessory.

- ▶ Press the connection cable into the cable gland on the MZQ 02 clip.

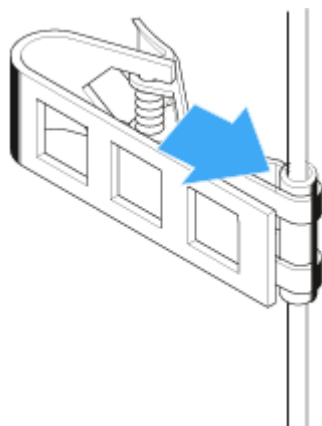

- ▶ Attach the cable clip to the rear of your collar.
- ▶ Run the connection cable under your clothing.



Connecting the microphone to the SL Bodypack DW

- ▶ Connect the jack plug of the Headmic 1 to the 3.5 mm jack socket (MIC/LINE) of the bodypack transmitter.
- ▶ Lock the jack plug by screwing down the coupling ring.

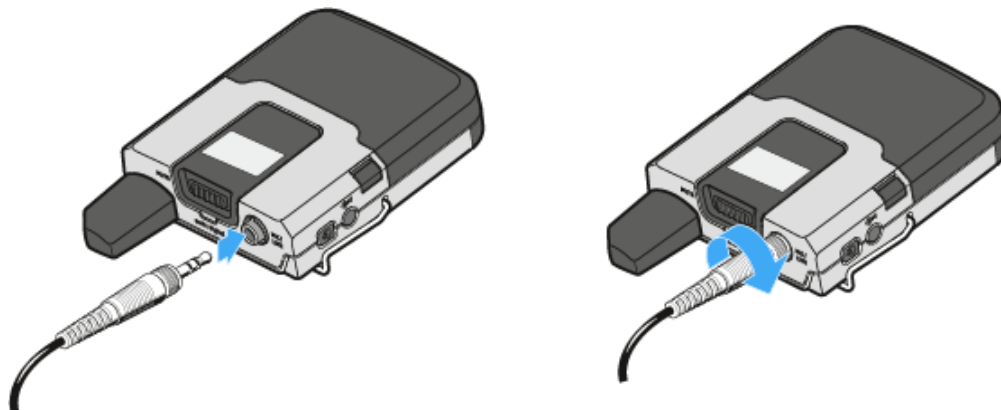

- ✓ When the jack plug is not firmly locked, crackling noise can appear in the audio signal.



The MKE 1 clip-on microphone

The MKE 1 is a high-quality, sub-miniature, sweat-resistant clip-on condenser microphone. It features excellent sound quality and rugged design. The frequency response curve has been optimized for stage, studio and reporting applications (ENG).

The MKE 1 is fitted with a very thin (only 1 mm) yet extremely rugged cable, making this microphone an ideal partner for all live sound applications.

Features

- Sub-miniature microphone
- High maximum sound pressure level
- Wide frequency response with adaptable treble response
- Thin (only 1 mm), flexible and rugged cable, low in handling noise
- Very insensitive to the penetration of sweat due to a special protective “umbrella” diaphragm

Treble boost

Your microphone is supplied with two different frequency response caps. These caps allow you to adjust the treble response of the microphone.

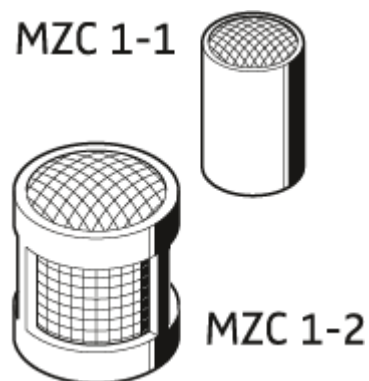

In addition, the large frequency response cap attenuates wind noise by approx. 15 dB and provides an extended protection against the ingress of moisture.

- ▶ Slip the cap of your choice onto the microphone until it locks into place.



Attaching the microphone

Depending on the area of application, you can attach the MKE 1 in different ways to either clothing or the body.

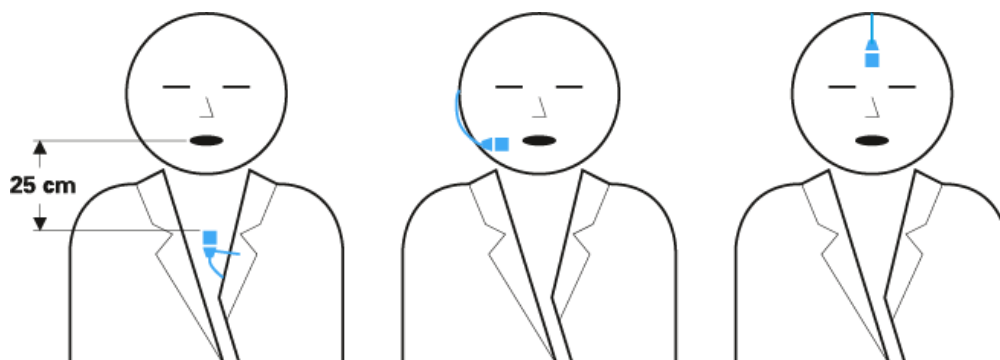

To do so, use the optional MZ 1 accessory kit that offers multiple and secure attachment possibilities. The clips, holders and mounts are suitable for almost any wearing situation and ensure optimum sound quality.



Connecting the microphone to the SL Bodypack DW

- ▶ Connect the jack plug of the Headmic 1 to the 3.5 mm jack socket (MIC/LINE) of the bodypack transmitter.
- ▶ Lock the jack plug by screwing down the coupling ring.

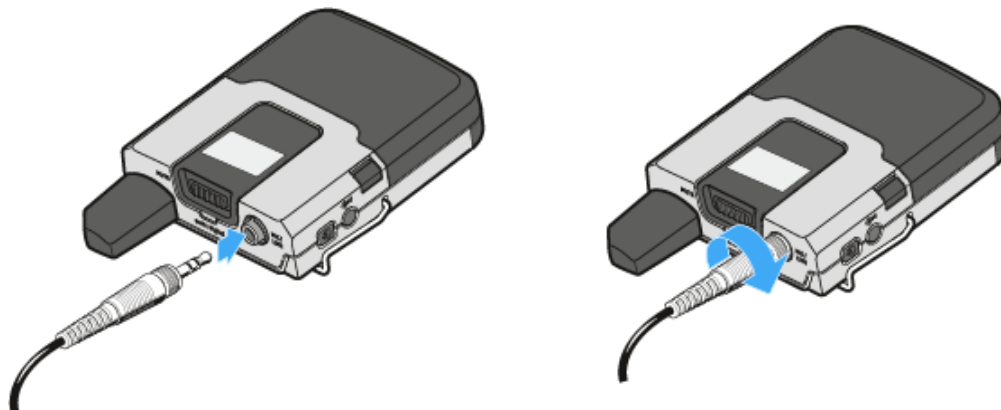

- ✓ When the jack plug is not firmly locked, crackling noise can appear in the audio signal.



The CHG 2 charger

The CHG 2 charger allows you to simultaneously charge up to two transmitters of the SpeechLine Digital Wireless series. A bi-color LED at each charging slot provides information on the current charge level. The charger has universal charging slots for charging both handheld and bodypack transmitters.

Product overview

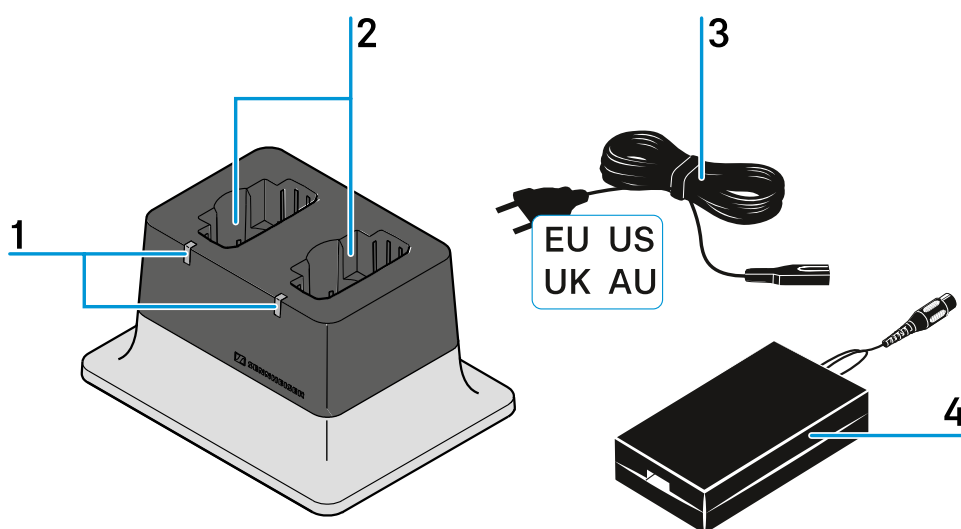

1 Charge level LEDs

lights up green: The accupack is fully charged.

lights up red: The accupack is being charged.

2 Charging slots

each suitable for both SL Handheld DW and SL Bodypack DW

3 Power cord

EU, US, UK or AU variant

4 NT 12-50CS power supply unit

with hollow jack plug for connection to the CHG 2 charger



Connecting the charger to the power supply system

To connect the CHG 2 charger to the power supply system:

- ▶ Connect the cable end of the power supply unit to the socket at the base of the charger.
- ▶ Guide the cable through one of the cable guides at the base of the charger so that the charger is stable once in position.
- ▶ Connect one end of the power cord to the power supply unit and the other end to the wall socket.

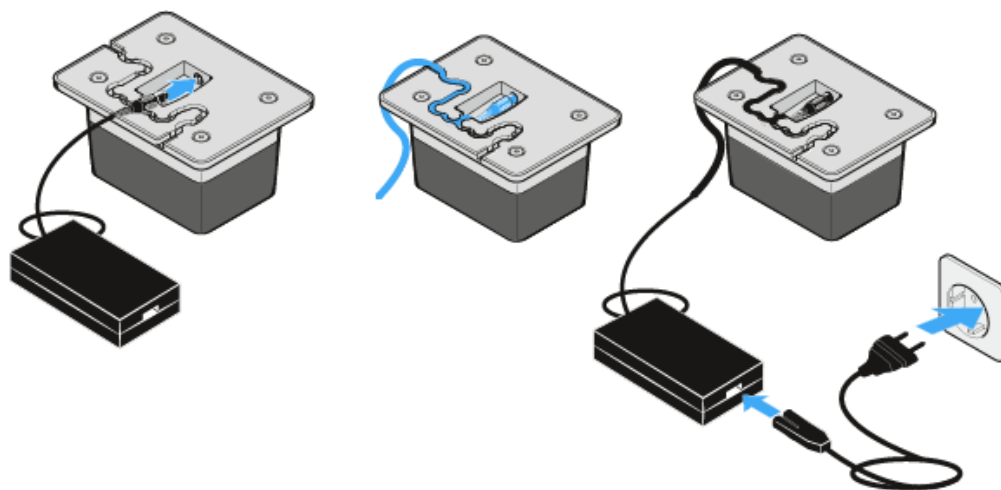



Charging the accupack in the charger

To charge an accupack in the CHG 2 charger:

- ▶ Insert the transmitter with the accupack installed and with the charging contacts facing downwards into the charger.

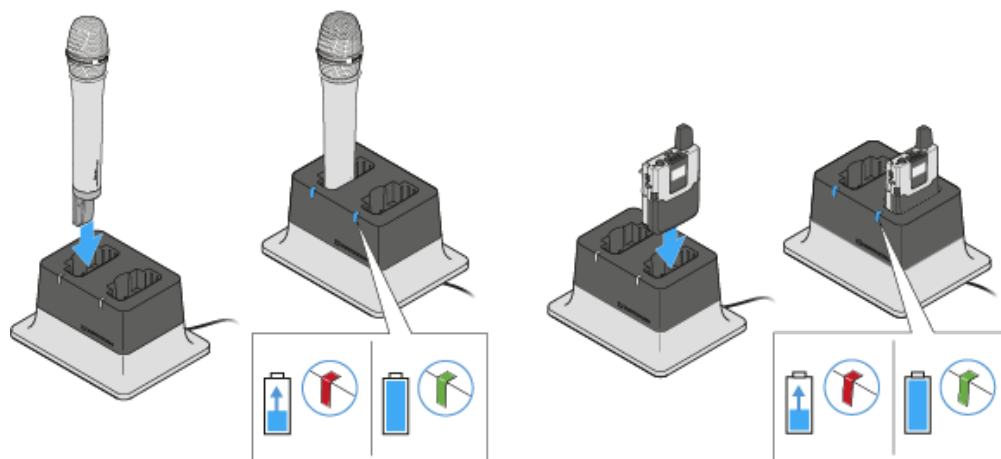

- ✓ Make sure to insert the transmitter the correct way round: The STANDBY button of the bodypack transmitter has to point in the direction of the charger's charge status LED.

The charge status LED lights up red when the accupack is being charged.

The charge status LED lights up green when the accupack is fully charged.



The CHG 2N charger

The CHG 2N is a network-compatible charger with two separate charging slots. These ports can be used for the SL Bodypack DW and the SL Handheld DW. The four LEDs on each charging slot indicate the current charging status. The versatile network interface is compatible with IPv4 and IPv6 for seamless integration. The Sennheiser Control Cockpit software can be used to monitor and remotely control the settings and status messages.

Product overview

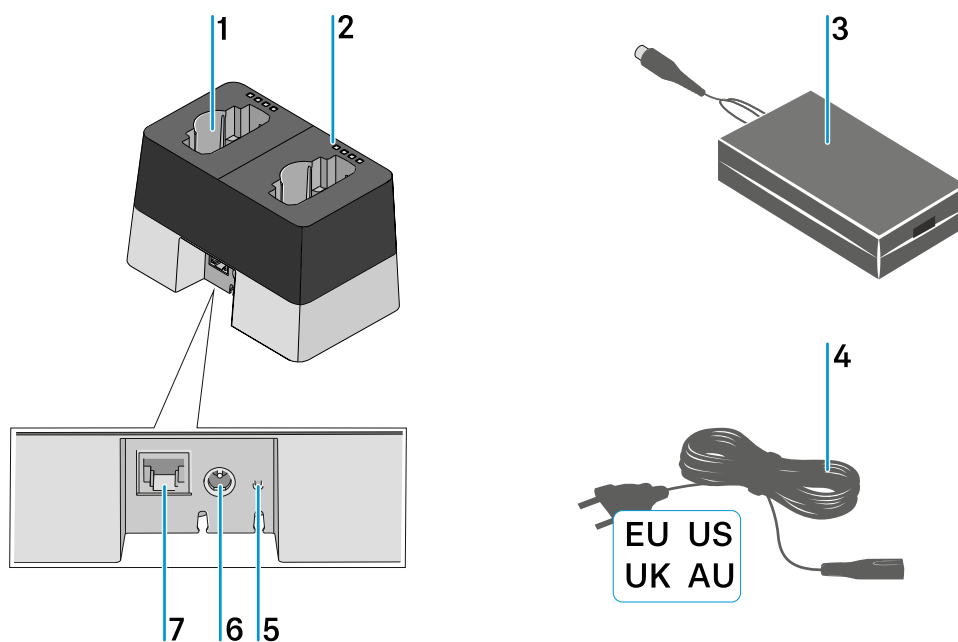

1 Charging slots

Each suitable for both SL Handheld DW and SL Bodypack DW

see [Charging the accupack in the charger](#)

2 Charge level LEDs

see [Meaning of the charging slot status LEDs](#)

3 Power supply unit

With hollow jack plug for connection to the CHG 2N charger

see [Connecting the charger to the power supply system](#)

4 Power cord

EU, US, UK or AU variant

see [Connecting the charger to the power supply system](#)

5 Network reset button

see [Resetting the charger's network settings](#)



6 Input socket for power supply unit

see [Connecting the charger to the power supply system](#)

7 Ethernet socket

see [Controlling and monitoring the charger over the network](#)



Connecting the charger to the power supply system

To connect the CHG 2N charger to the power supply system:

- ▶ Connect the cable end of the power supply unit to the socket at the base of the charger.

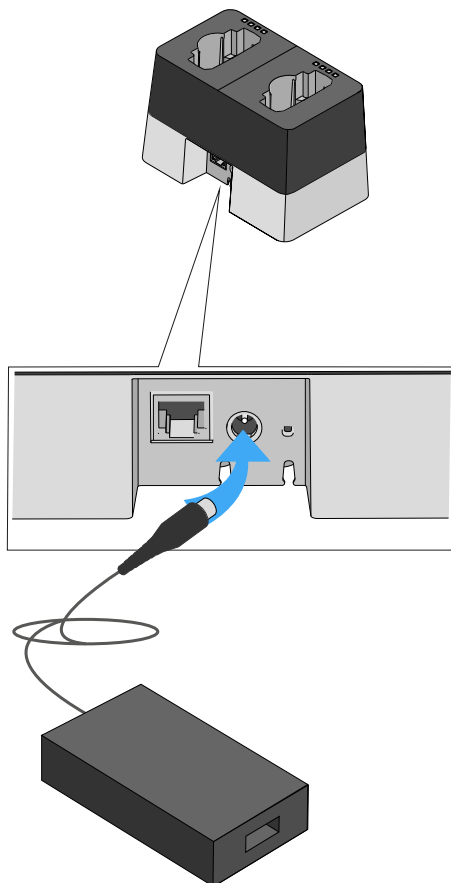

- ▶ Guide the cable through the cable guide at the base of the charger so that the charger is stable once in position.

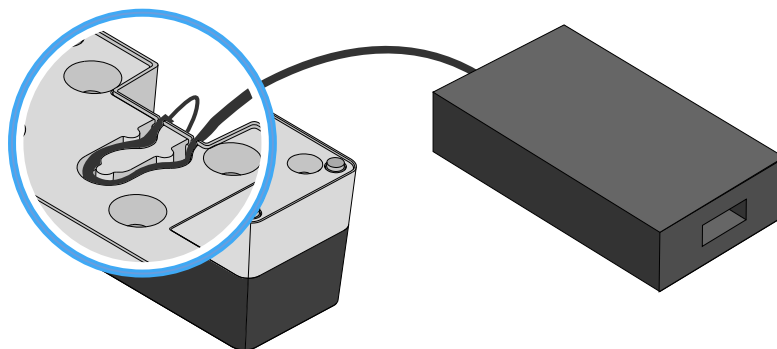



- ▶ Connect one end of the power cord to the power supply unit and the other end to the wall socket.

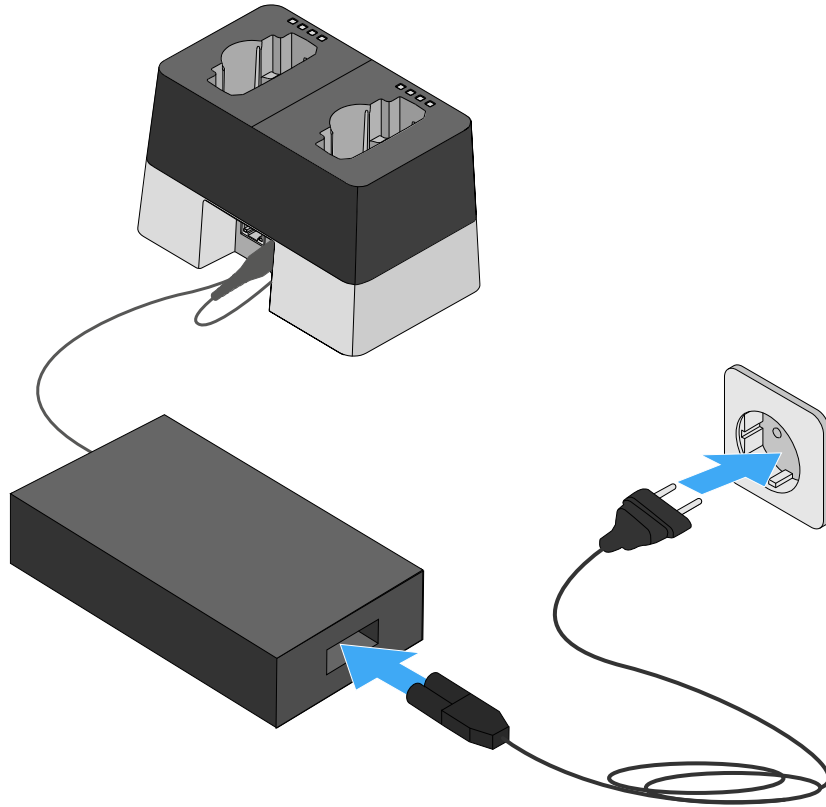



Charging the accupack in the charger

To charge an accupack in the CHG 2N charger:

- ▶ Insert the transmitter with installed accupack into one of the charger's two charging slots. Make sure the charging contacts face downward.

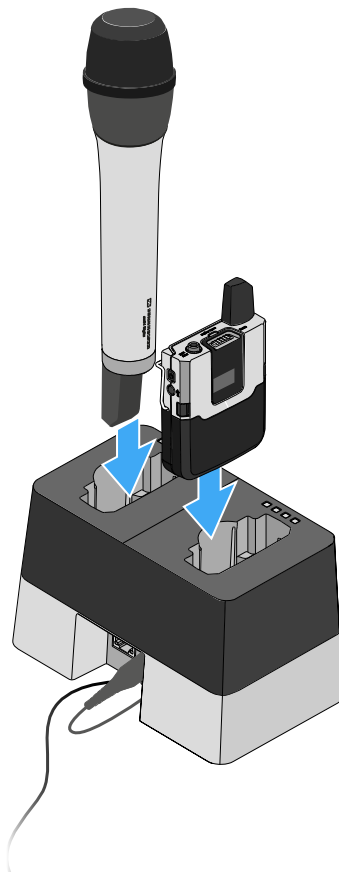

































- ▶ Make sure to insert the transmitter the correct way round. The transmitter fits into the charger in only one direction.
 - ✔ The four charge level LEDs for each of the four charging slots indicate the accupack's current charge level, see [Meaning of the charging slot status LEDs](#).



Meaning of the charging slot status LEDs

Die vier Status-LEDs jedes einzelnen Ladeschachtes können die folgenden Statusinformationen anzeigen:

				Accupack charge level = 100 %
				Accupack charge level < 100 %
				Accupack charge level < 66 %
				Accupack charge level < 33 %
				An error has occurred. A corresponding error message is displayed in the Sennheiser Control Cockpit software.
				The firmware of the charger is being updated. This LED status is also displayed when new firmware for an SL Handheld DW or SL Bodypack DW transmitter is being loaded to the charger. Once the transmitter firmware has been loaded and the actual update has been performed, the LED switches to the following status.
				The firmware of the SL Handheld DW or SL Bodypack DW transmitter is being updated.
				The transmitter is not supported or requires a firmware update.



Controlling and monitoring the charger over the network

You can connect the CHG 2N charger to a network using a router or switch, which allows you to monitor and control the accupack's charge level using the **Sennheiser Control Cockpit** software and to modify the CHG 2N charger's network configuration.

For more information on controlling a system in the network using the **Sennheiser Control Cockpit** software, refer to the instruction manual of the software.

Please note that the host PC on which the **Sennheiser Control Cockpit Service** is installed must be in the same network as the devices that are to be monitored and controlled.

Connecting the charger to the network

To connect the charger using the **Sennheiser Control Cockpit** app:

- ▶ Connect a standard network cable (at least Cat 5) to the Ethernet socket of the charger.

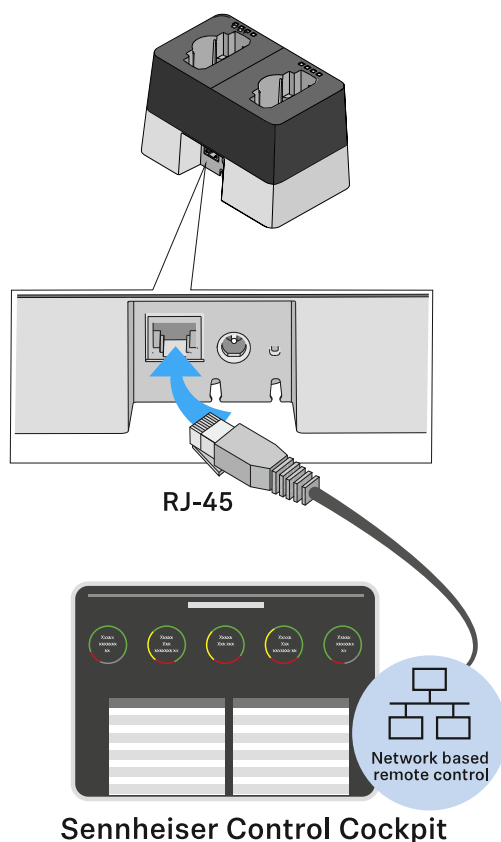

- ▶ Connect the other end of the network cable to the network, e.g. to a switch or router, or directly to a PC to make initial configuration easier.



- ✓ The yellow LED next to the CHG 2N charger's Ethernet socket indicates the connection status:
 - On -> The charger is connected to the network
 - Off -> The charger is not connected to the network



Integrating the charger into a network with DHCP

If a DHCP server is active in the selected network, the charger receives an IP address automatically.

The charger is automatically detected in the Sennheiser Control Cockpit once it is connected to the network, since the CHG 2N is delivered with mDNS activated by default.

You can deactivate mDNS after you have configured the charger once. The IP address may change during operation, depending on the lease time and the DHCP server settings.

i mDNS = multicast Domain Name System: resolves host names to IP addresses within small networks that do not include a local name server. Used for automatic device discovery.



Integrating the charger into a network without DHCP using Auto IP

If there is no DHCP server in the network and you are working with automatically generated IP addresses, please observe the following information.

- ▶ Ensure that the host PC on which the Sennheiser Control Cockpit service is installed is configured so that the IP address is assigned automatically, rather than a static configuration.
- ✓ After several minutes, all chargers in the network will receive a link-local address in the range of 169.254.x.x.

The charger is automatically detected in the Sennheiser Control Cockpit, since the charger is delivered with mDNS activated by default.

You can deactivate mDNS after you have configured the charger once.

i mDNS = multicast Domain Name System: resolves host names to IP addresses within small networks that do not include a local name server. Used for automatic device discovery.

i Some basic routers with an integrated DHCP server require more time to start. In this case, the SpeechLine devices may initially receive an automatically assigned IP. Once a DHCP server is available, however, the IP addresses assigned by the server will be used.



Integrating the charger into a network without DHCP using Fixed IP

If there is no DHCP server in the network and you are working with fixed IP addresses, please observe the following information.

The charger is delivered with automatic IP assignment configured by default. After adding it in the **Sennheiser Control Cockpit**, you can reconfigure it to Fixed IP. To do so, proceed as described: [Integrating the charger into a network without DHCP using Auto IP](#).

If you wish to do this, you must temporarily reconfigure the host PC on which the **Sennheiser Control Cockpit** is installed to automatic IP assignment.

If the CHG 2N charger is visible in the Sennheiser Control Cockpit, you can do the IP configuration manually:

- ▶ Change the IP settings under **Device Details -> Network** in the **Sennheiser Control Cockpit**.



Connecting a pre-configured charger to the Sennheiser Control Cockpit

If mDNS is activated (factory setting), the charger is automatically detected in the network.

If the charger has been reconfigured according to one of the procedures described above and mDNS has been deactivated, you can add the charger manually using the **Add Device** function in the **Sennheiser Control Cockpit**.

To add the charger in the Sennheiser Control Cockpit:

- ▶ Use the **Add Device** function in the **Sennheiser Control Cockpit** and enter the pre-configured IP address.



Resetting the charger's network settings

To reset the network settings to their factory defaults:

- ▶ Use a pointed object to press the small reset button for at least one second.

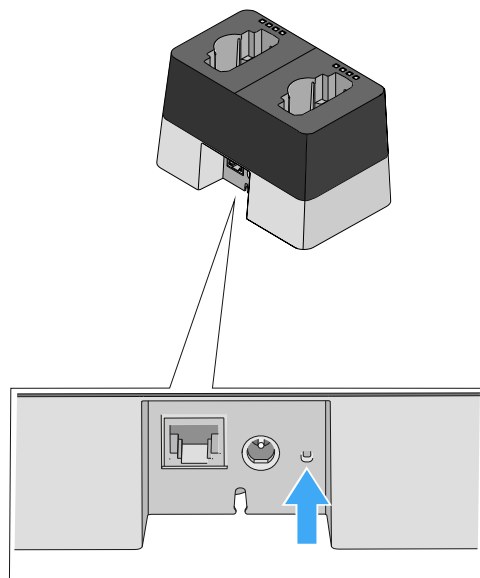

- ✓ The settings will be reset once you release the reset button. The factory settings are restored:

Automatic IP assignment

mDNS is activated

Name and installation location are reset, provided they were changed in the Sennheiser Control Cockpit.



Activating power saving mode

In power saving mode, the transmitters are charged only once. The charger also does not provide any trickle charge.

To activate power saving mode:

- ▶ Hold the network reset button for 10 seconds.

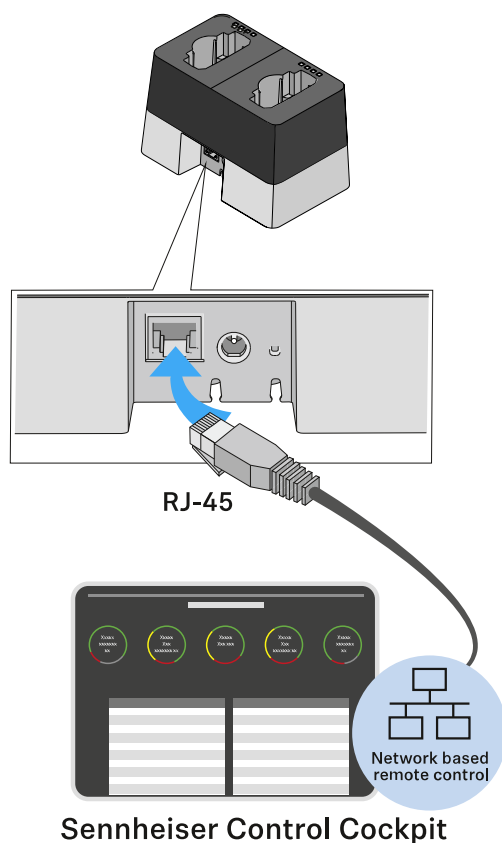

- ✓ All LEDs will light up once and power saving mode will be activated.

All LEDs remain off while power saving mode is activated. They do not light up even during the one-time charging process.

To deactivate power saving mode:

- ▶ Disconnect the charger from the power supply system.
- ▶ Then reconnect it to the power supply system.
- ✓ The charger will start up in the configuration that was set before you activated power saving mode.



Updating the firmware

The firmware of the charger is updated using the **Sennheiser Control Cockpit** software.

You can find more information about this procedure in the software instruction manual or in the **download area** of the Sennheiser website.

[Control Cockpit](#)

sennheiser.com/download



The CHG 4N charger

The CHG 4N is a network-compatible charger with four separate charging slots. These ports can be used for the SL Bodypack DW and the SL Handheld DW. The four LEDs on each charging slot indicate the current charging status. The versatile network interface is compatible with IPv4 and IPv6 for seamless integration. The Sennheiser Control Cockpit software can be used to monitor and remotely control the settings and status messages.

Product overview

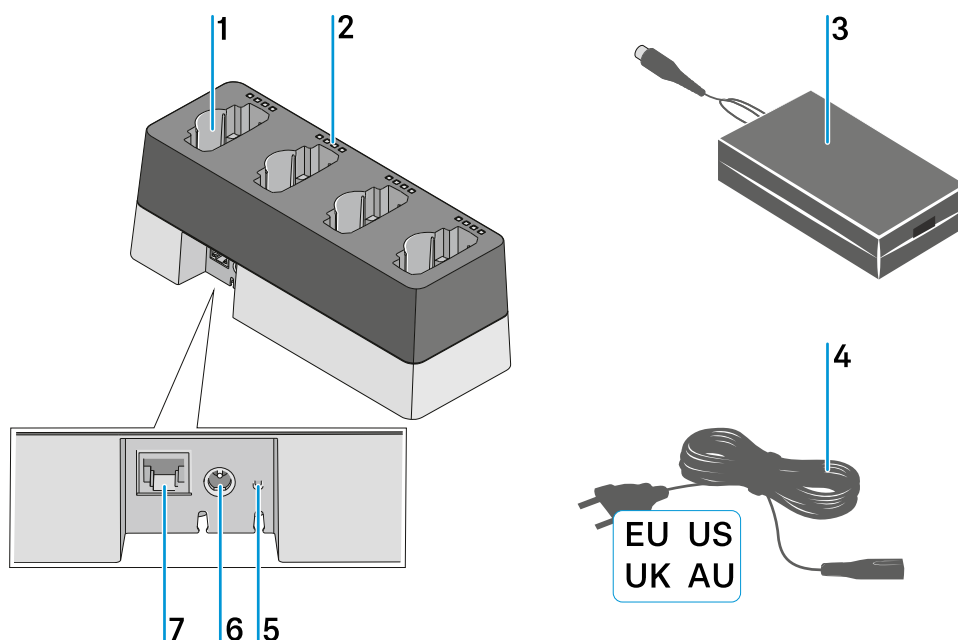

1 Charging slots

Each suitable for both SL Handheld DW and SL Bodypack DW

see [Charging the accupack in the charger](#)

2 Charge level LEDs

see [Meaning of the charging slot status LEDs](#)

3 Power supply unit

With hollow jack plug for connection to the CHG 4N charger

see [Connecting the charger to the power supply system](#)

4 Power cord

EU, US, UK or AU variant

see [Connecting the charger to the power supply system](#)

5 Network reset button

see [Resetting the charger's network settings](#)



6 Input socket for power supply unit

see [Connecting the charger to the power supply system](#)

7 Ethernet socket

see [Controlling and monitoring the charger over the network](#)



Connecting the charger to the power supply system

To connect the CHG 4N charger to the power supply system:

- ▶ Connect the cable end of the power supply unit to the socket at the base of the charger.

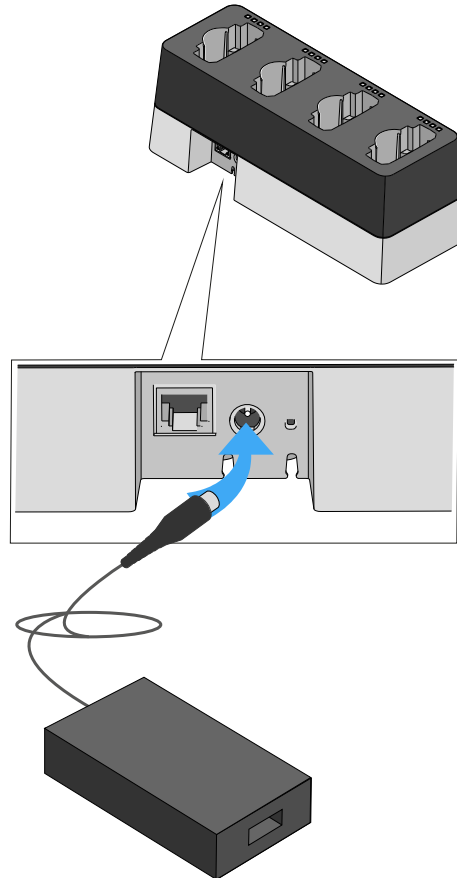

- ▶ Guide the cable through the cable guide at the base of the charger so that the charger is stable once in position.

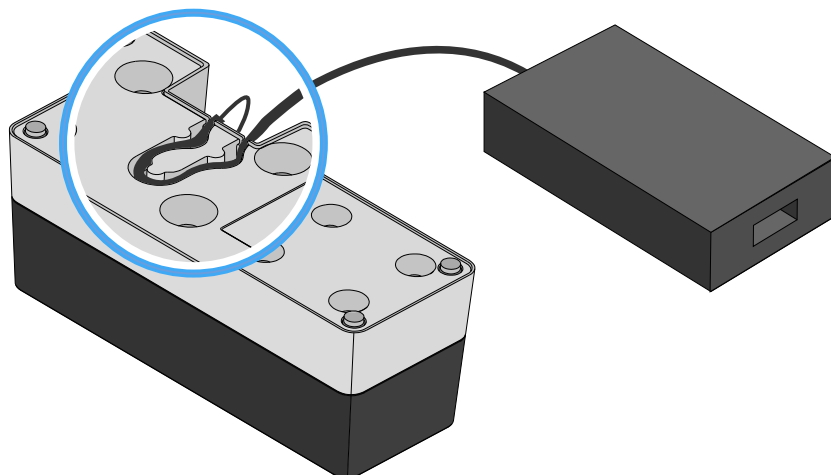



- ▶ Connect one end of the power cord to the power supply unit and the other end to the wall socket.

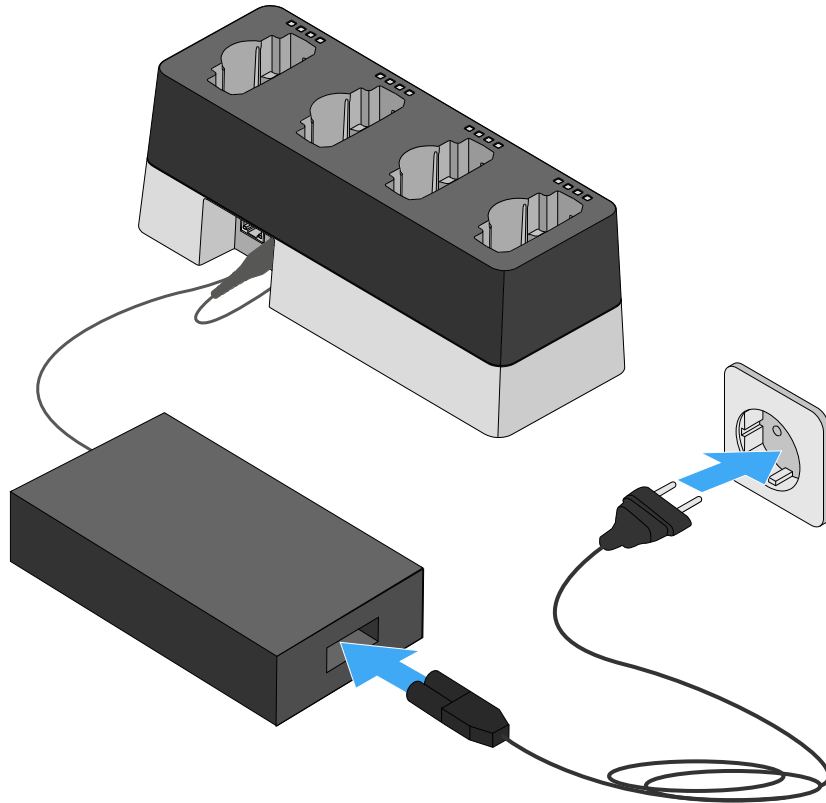



Charging the accupack in the charger

To charge an accupack in the CHG 4N charger:

- ▶ Insert the transmitter with installed accupack into one of the charger's four charging slots. Make sure the charging contacts face downward.

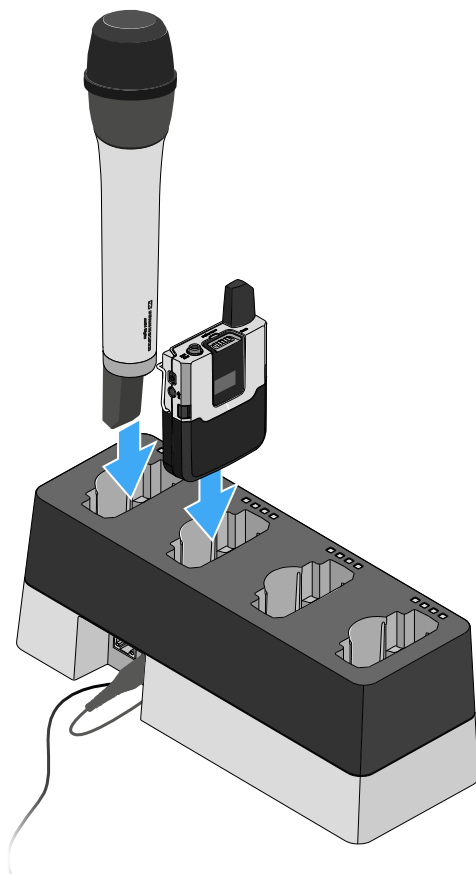

- ▶ Make sure to insert the transmitter the correct way round. The transmitter fits into the charger in only one direction.
 - ✔ The four charge level LEDs for each of the four charging slots indicate the accupack's current charge level, see [Meaning of the charging slot status LEDs](#).



Meaning of the charging slot status LEDs

Die vier Status-LEDs jedes einzelnen Ladeschachtes können die folgenden Statusinformationen anzeigen:

	Accupack charge level = 100 %
	Accupack charge level < 100 %
	Accupack charge level < 66 %
	Accupack charge level < 33 %
	An error has occurred. A corresponding error message is displayed in the Sennheiser Control Cockpit software.
	The firmware of the charger is being updated. This LED status is also displayed when new firmware for an SL Handheld DW or SL Bodypack DW transmitter is being loaded to the charger. Once the transmitter firmware has been loaded and the actual update has been performed, the LED switches to the following status.
	The firmware of the SL Handheld DW or SL Bodypack DW transmitter is being updated.
	The transmitter is not supported or requires a firmware update.



Controlling and monitoring the charger over the network

You can connect the CHG 4N charger to a network using a router or switch, which allows you to monitor and control the accupack's charge level using the **Sennheiser Control Cockpit** software and to modify the CHG 4N charger's network configuration.

For more information on controlling a system in the network using the **Sennheiser Control Cockpit** software, refer to the instruction manual of the software.

Please note that the host PC on which the **Sennheiser Control Cockpit Service** is installed must be in the same network as the devices that are to be monitored and controlled.

Connecting the charger to the network

To connect the charger using the **Sennheiser Control Cockpit** app:

- ▶ Connect a standard network cable (at least Cat 5) to the Ethernet socket of the charger.

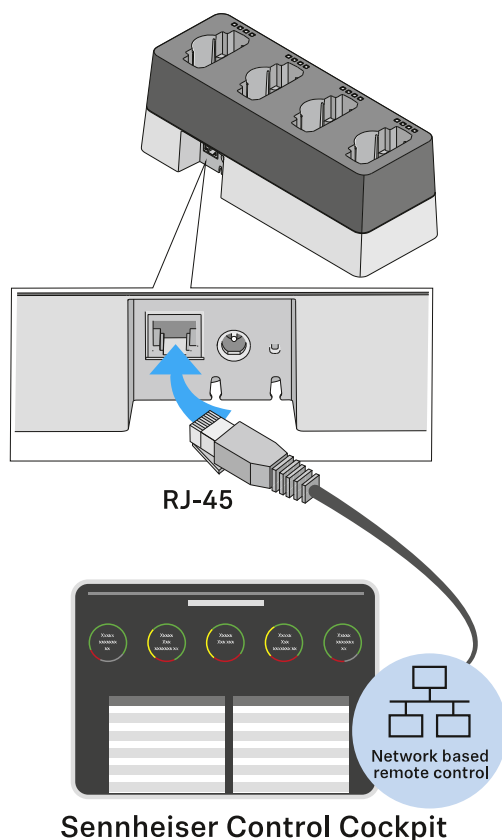

- ▶ Connect the other end of the network cable to the network, e.g. to a switch or router, or directly to a PC to make initial configuration easier.



- ✓ The yellow LED next to the CHG 4N charger's Ethernet socket indicates the connection status:
 - On -> The charger is connected to the network
 - Off -> The charger is not connected to the network



Integrating the charger into a network with DHCP

If a DHCP server is active in the selected network, the charger receives an IP address automatically.

The charger is automatically detected in the Sennheiser Control Cockpit once it is connected to the network, since the CHG 2N is delivered with mDNS activated by default.

You can deactivate mDNS after you have configured the charger once. The IP address may change during operation, depending on the lease time and the DHCP server settings.

i mDNS = multicast Domain Name System: resolves host names to IP addresses within small networks that do not include a local name server. Used for automatic device discovery.



Integrating the charger into a network without DHCP using Auto IP

If there is no DHCP server in the network and you are working with automatically generated IP addresses, please observe the following information.

- ▶ Ensure that the host PC on which the Sennheiser Control Cockpit service is installed is configured so that the IP address is assigned automatically, rather than a static configuration.
- ✓ After several minutes, all chargers in the network will receive a link-local address in the range of 169.254.x.x.

The charger is automatically detected in the Sennheiser Control Cockpit, since the charger is delivered with mDNS activated by default.

You can deactivate mDNS after you have configured the charger once.

i mDNS = multicast Domain Name System: resolves host names to IP addresses within small networks that do not include a local name server. Used for automatic device discovery.

i Some basic routers with an integrated DHCP server require more time to start. In this case, the SpeechLine devices may initially receive an automatically assigned IP. Once a DHCP server is available, however, the IP addresses assigned by the server will be used.



Integrating the charger into a network without DHCP using Fixed IP

If there is no DHCP server in the network and you are working with fixed IP addresses, please observe the following information.

The charger is delivered with automatic IP assignment configured by default. After adding it in the **Sennheiser Control Cockpit**, you can reconfigure it to Fixed IP. To do so, proceed as described: [Integrating the charger into a network without DHCP using Auto IP](#).

If you wish to do this, you must temporarily reconfigure the host PC on which the **Sennheiser Control Cockpit** is installed to automatic IP assignment.

If the CHG 2N charger is visible in the Sennheiser Control Cockpit, you can do the IP configuration manually:

- ▶ Change the IP settings under **Device Details -> Network** in the **Sennheiser Control Cockpit**.



Connecting a pre-configured charger to the Sennheiser Control Cockpit

If mDNS is activated (factory setting), the charger is automatically detected in the network.

If the charger has been reconfigured according to one of the procedures described above and mDNS has been deactivated, you can add the charger manually using the **Add Device** function in the **Sennheiser Control Cockpit**.

To add the charger in the Sennheiser Control Cockpit:

- ▶ Use the **Add Device** function in the **Sennheiser Control Cockpit** and enter the pre-configured IP address.



Resetting the charger's network settings

To reset the network settings to their factory defaults:

- ▶ Use a pointed object to press the small reset button for at least one second.

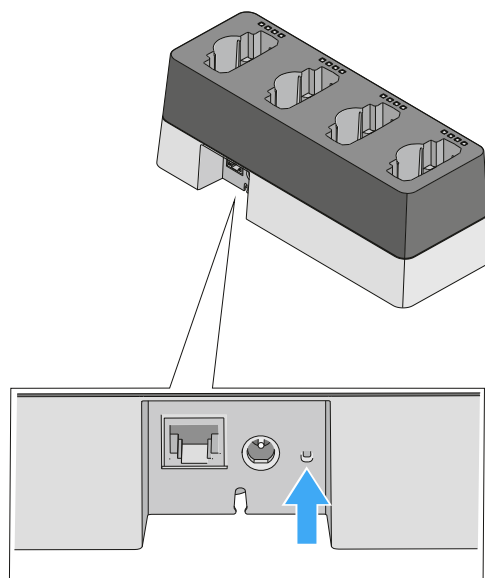

- ✓ The settings will be reset once you release the reset button. The factory settings are restored:

Automatic IP assignment

mDNS is activated

Name and installation location are reset, provided they were changed in the Sennheiser Control Cockpit.



Activating power saving mode

In power saving mode, the transmitters are charged only once. The charger also does not provide any trickle charge.

i This function is available in firmware version 2.0.3 and later.

To activate power saving mode:

- ▶ Hold the network reset button for 10 seconds.

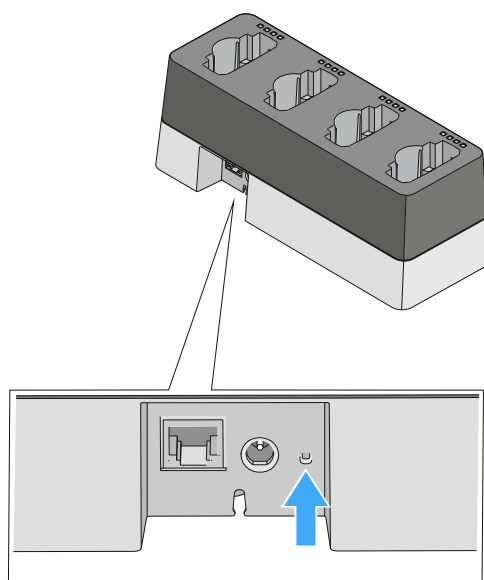

- ✓ All LEDs will light up once and power saving mode will be activated.

All LEDs remain off while power saving mode is activated. They do not light up even during the one-time charging process.

To deactivate power saving mode:

- ▶ Disconnect the charger from the power supply system.
- ▶ Then reconnect it to the power supply system.
- ✓ The charger will start up in the configuration that was set before you activated power saving mode.



Updating the firmware

The firmware of the charger is updated using the **Sennheiser Control Cockpit** software.

You can find more information about this procedure in the software instruction manual or in the **download area** of the Sennheiser website.

[Control Cockpit](#)

sennheiser.com/download



The CHG 2W charging base

The CHG 2W is a wireless charging base that provides convenient wireless charging. The CHG 2W charging base is compatible with the SL Tablestand 133-S DW, the SL Tablestand 153-S DW and the SL Boundary 114-S DW.

Product overview

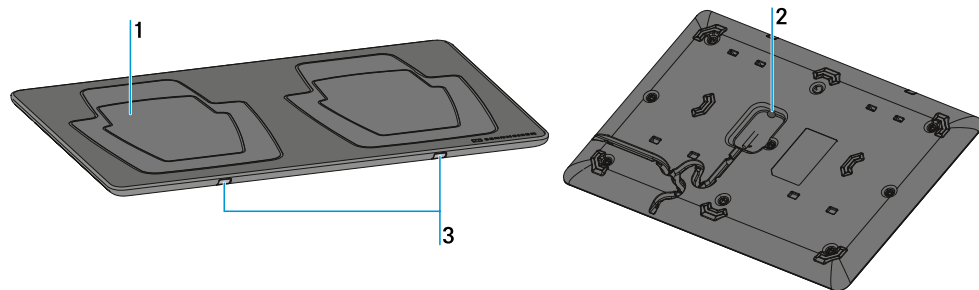

1 Charging surface for wireless energy transfer

For the SL Tablestand 133-S DW and SL Tablestand 153-S DW units

see [Charging a device using the charging base](#)

2 Socket for power supply unit

see [Connecting the charging base to the power supply system](#)

3 Status LEDs

see [Meaning of the status LEDs on the charging surfaces](#)



Connecting the charging base to the power supply system

To connect the CHG 2W charger to the power supply system:

- ▶ Connect the cable end of the power supply unit to the socket at the base of the charger.
- ▶ Make sure you insert the plug all the way. You should feel it lock into place.
- ▶ Guide the cable through one of the two cable guides at the base of the charger so that the charger is stable once in position.
- ▶ Plug the power supply unit into a wall socket.

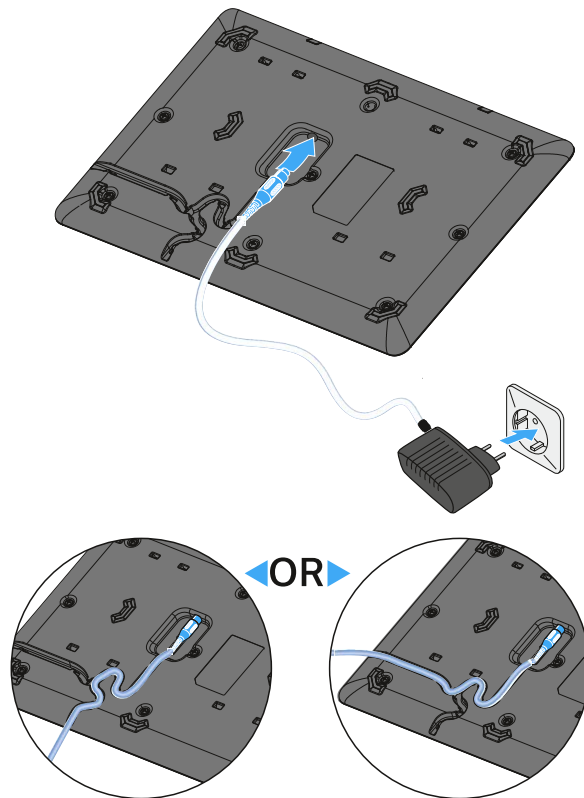



Charging a device using the charging base

You can use the CHG 2W charging base to charge the wireless table stands SL Tablestand 133-S DW and SL Tablestand 153-S DW as well as the wireless boundary microphone SL Boundary 114-S DW.

To charge a device:

- ▶ Place the device on one of the two charging surfaces.

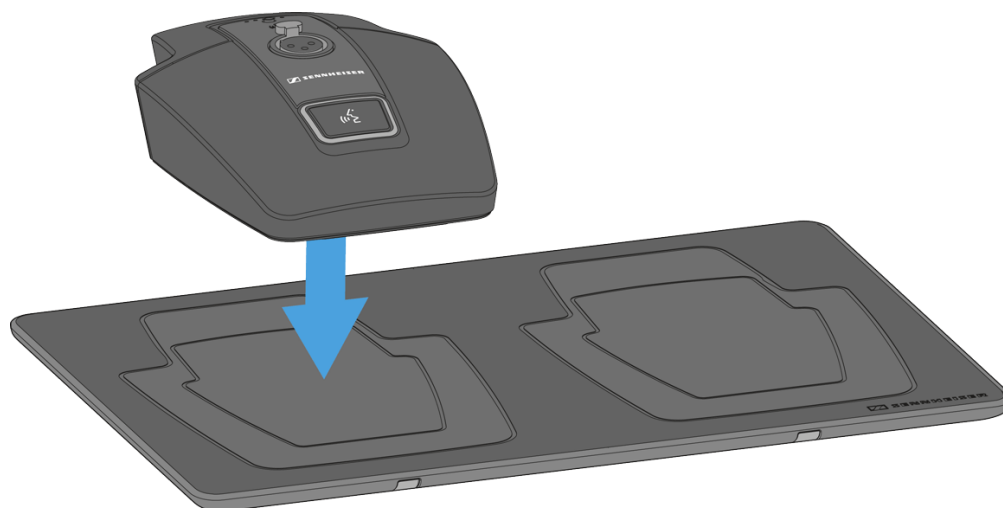

- ✔ The blue status LED for the active charging surface flashes during the charging process.

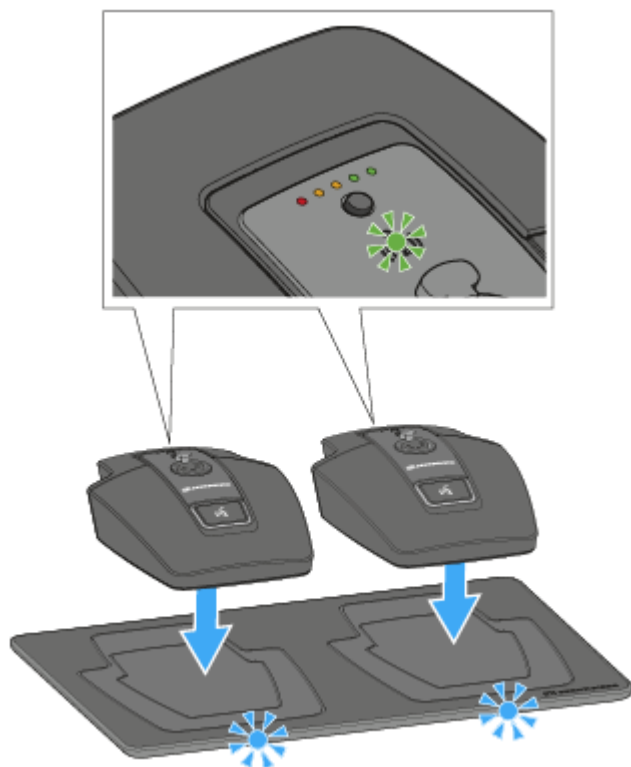

The alignment LED on the device tells you whether the device is correctly positioned.





Meaning of the status LEDs on the charging surfaces

The two blue status LEDs on the charging surfaces provide the following status information:

-  Flashing normally: the device is charging
-  Flashing rapidly: excess temperature warning
-  Flashing/flickering very rapidly: unknown device on the charger



AWM 2 / AWM 4 remote antennas

The AWM 2 and AWM 4 antennas for wall mounting can be mounted away from the receivers so that they are in the optimum position and virtually invisible. This is useful, for example, when the receivers need to be installed in such a way that they cannot be seen or when the receiver position is not the optimum position for the antenna. The AWM 2 or AWM 4 can be easily mounted on a microphone stand or permanently installed on a wall.

i You can find additional information on possible setups using the AWM 2 and AWM 4 as well as general recommendations on antenna usage under [Recommendations on antenna mounting](#).

Product overview

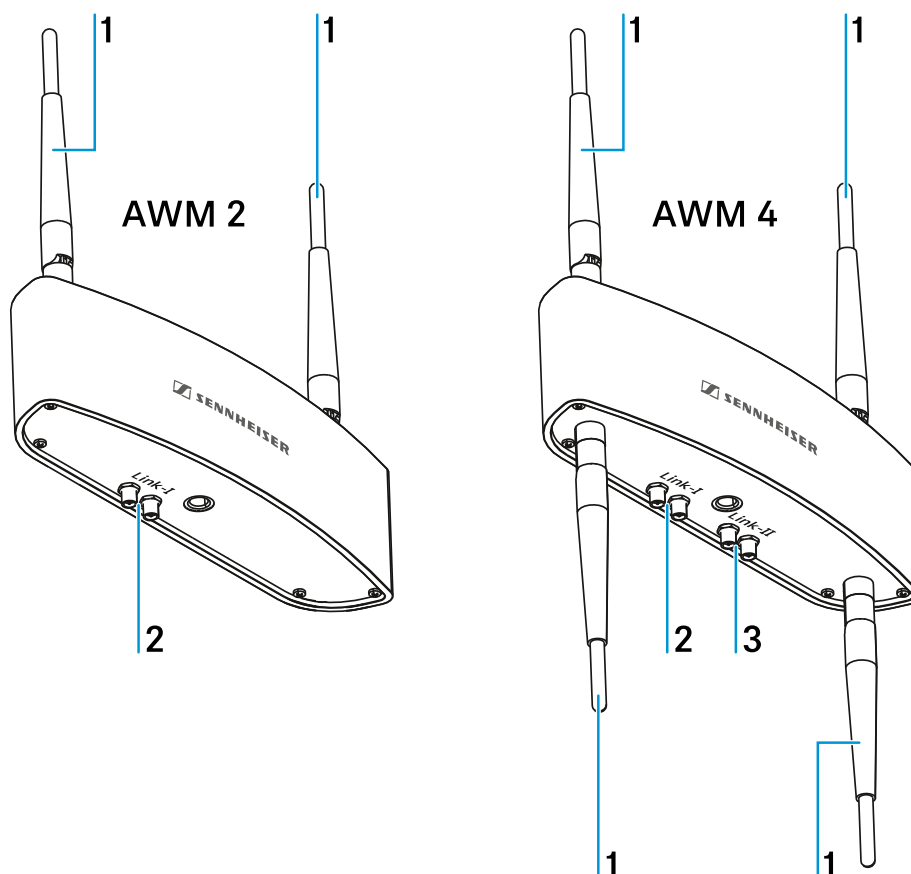

- 1 Antennas
- 2 Connections for Link I
- 3 Connections for Link II (AWM 4 only)



Attaching the antennas

- ▶ Screw the supplied rod antennas onto the housing as shown.

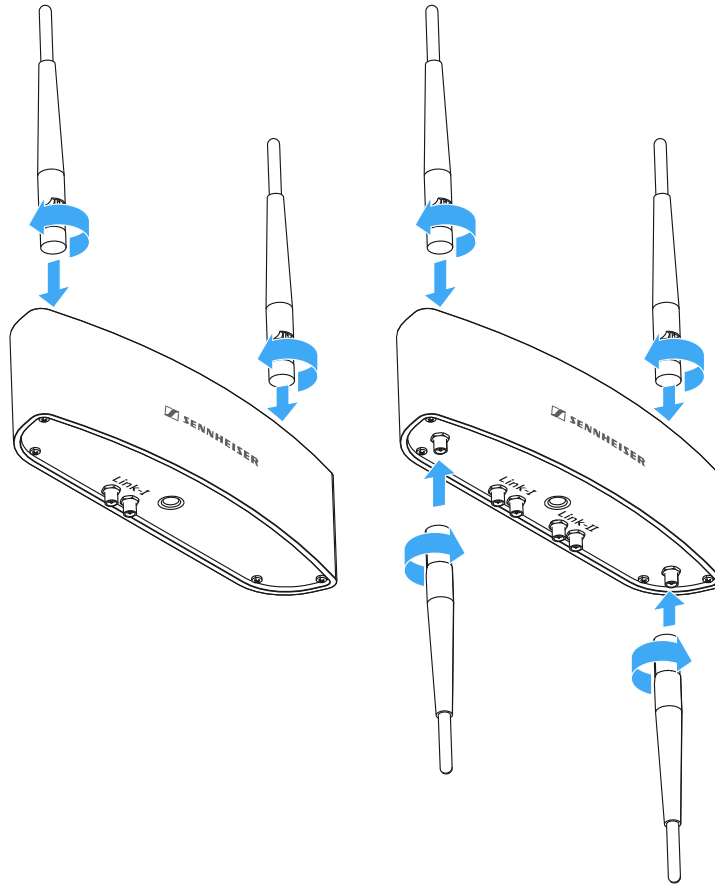



Connecting the antenna cables

You can connect one receiver directly to the AWM 2 and two receivers directly to the AWM 4.

- ▶ Connect the two antenna outputs ANT I and ANT II of the first receiver to the connections LINK I of the AWM 2 or AWM 4.
- ▶ Connect the two antenna outputs ANT I and ANT II of the second receiver to the connections LINK II of the AWM 4.

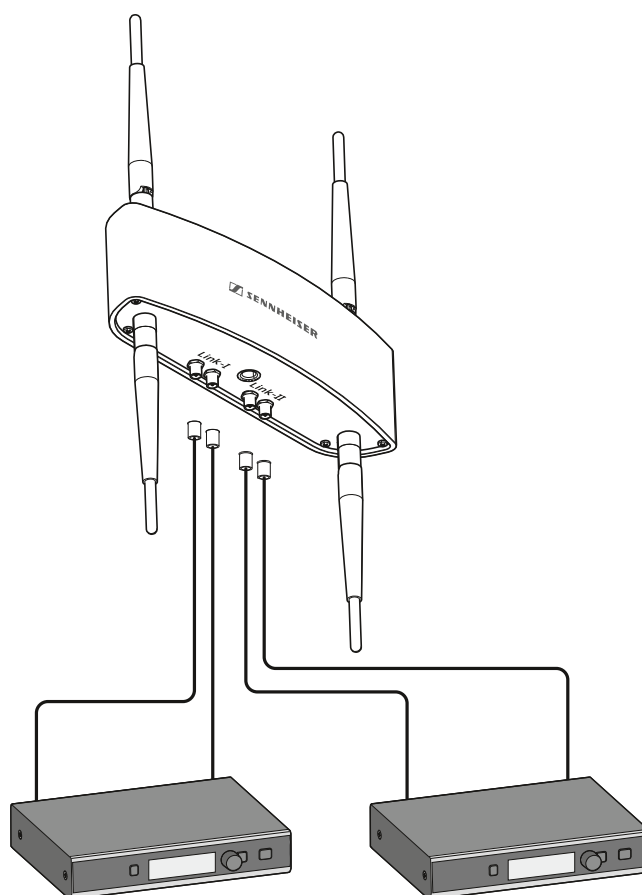

- i** You can find additional information on possible setups using the AWM 2 and AWM 4 as well as general recommendations on antenna usage under [Recommendations on antenna mounting](#).

For direct connection of the receivers to the AWM 2 or AWM 4, we recommend using the following low-loss Sennheiser antenna cables:

- CL 1 PP
- CL 5 PP
- CL 10 PP
- CL 20 PP



These cables can be directly connected to the SL Rack Receiver DW and the AWM 2 or AWM 4 without the need for an adapter.



Mounting the antenna on a stand or on the wall

- ▶ You can either screw the AWM 2 and AWM 4 onto a standard microphone stand or use the existing holes in the housing to mount it on the wall as shown.

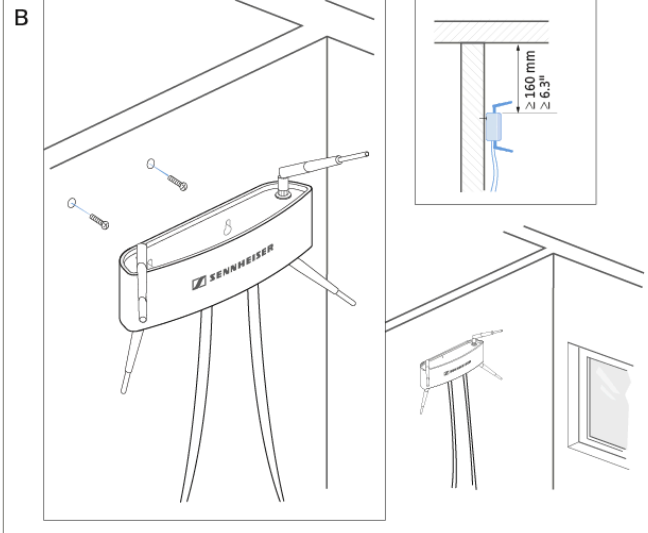
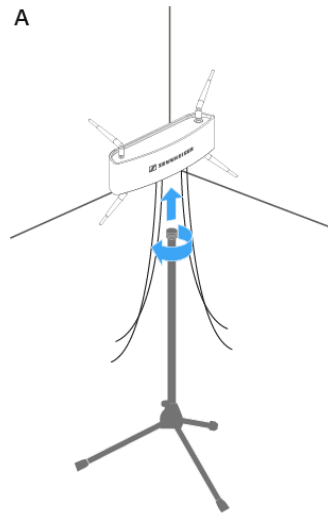



The SL PASC 2 passive antenna splitter/combiner

The SL PASC 2 is a passive two-way true diversity antenna splitter/combiner for the SpeechLine Digital Wireless microphone series. It is used to distribute the antenna signals from up to 2 SpeechLine Digital Wireless radio links. In combination with the AWM 2 or AWM 4 remote antennas, the number of required antenna cables is reduced to a minimum. The rack receivers are connected to the SL PASC 2 using the supplied SMA-R cables.

Connectors on the rear of the device

Product overview – SL PASC 2 rear panel

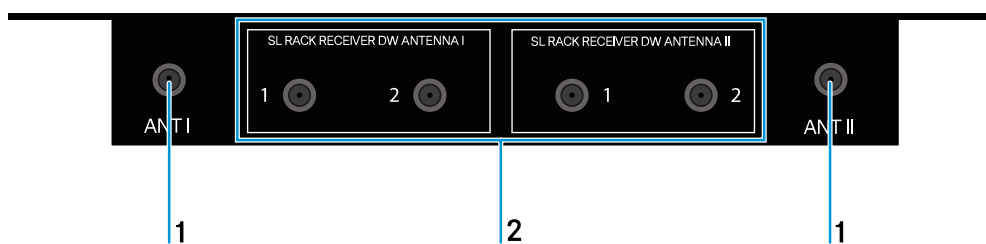

1 R-SMA output sockets ANT I and ANT II

for connecting the antennas (AWM 2 or AWM 4)

2 R-SMA input sockets SL RACK RECEIVER DW ANTENNA I and SL RACK RECEIVER DW ANTENNA II

for connecting the receivers

i You can find more information on wiring in the chapter [Option 2: Combining multiple links to one AWM 2/AWM 4](#).



The SL PASC 4 passive antenna splitter/combiner

The SL PASC 4 is a passive four-way true diversity antenna splitter/combiner for the SpeechLine Digital Wireless microphone series. It is used to distribute the antenna signals from up to 4 SpeechLine Digital Wireless radio links. In combination with the AWM 2 or AWM 4 remote antennas, the number of required antenna cables is reduced to a minimum. The rack receivers are connected to the SL PASC 4 using the supplied SMA-R cables.

Connectors on the rear of the device

Product overview – SL PASC 4 rear panel

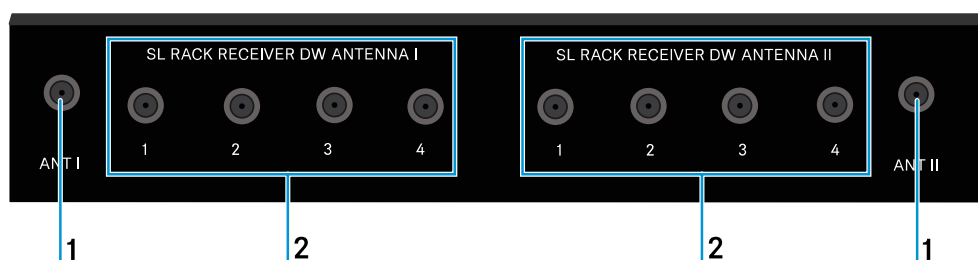

1 R-SMA output sockets ANT I and ANT II

for connecting the antennas (AWM 2 or AWM 4)

2 R-SMA input sockets SL RACK RECEIVER DW ANTENNA I and SL RACK RECEIVER DW ANTENNA II

for connecting the receivers

i You can find more information on wiring in the chapter [Option 2: Combining multiple links to one AWM 2/AWM 4](#).



Installing antenna splitters in a rack

This chapter describes how to install a single antenna splitter or two antenna splitters side by side in a rack.

To install the antenna splitter in a rack, you need the GA 4 mounting kit, see [GA 4 mounting kit](#).

To fasten the mounting angles (to install an antenna splitter):

- ▶ Remove the two recessed head screws on each side of the antenna splitter.
- ▶ Fasten the mounting angles to the sides of the antenna splitter by tightening the previously removed recessed head screws.

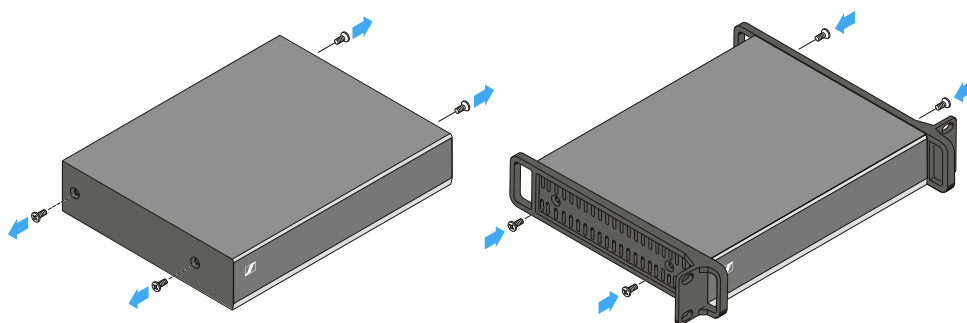

- ✔ Make sure that the angled ends of the mounting angles point forward.



To install the antenna splitter in a rack:

- ▶ Screw the front panel from the GA 4 mounting kit onto the antenna splitter's mounting angle using the two included recessed head screws as shown in the figure.

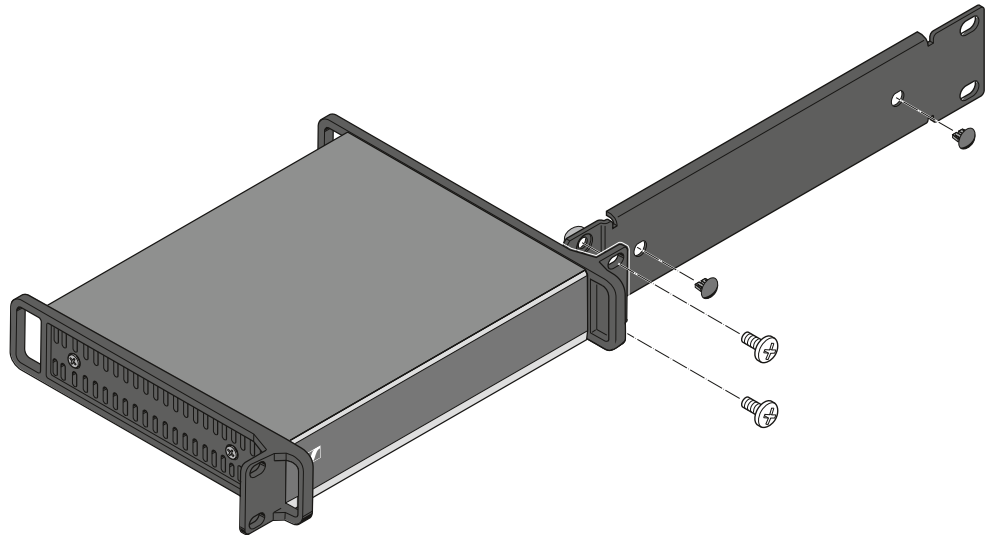

- ✓ Make sure to use the correct side (the one with the round holes) of the blanking plate to secure it to the mounting angle.
- ▶ Insert the two small blanking plugs into the unused antenna holes.
- ▶ Screw the unit consisting of antenna splitter and mounting accessories into a 19" rack.

To fasten the mounting angles: (to install two antenna splitters side by side):

- ▶ Remove the two recessed head screws on both outer-facing sides of the antenna splitters.
- ▶ Fasten the mounting angles to the outer-facing sides of the antenna splitters using the previously removed recessed head screws.

To mount the jointing plate:

- ▶ Place the two antenna splitters side by side on a flat surface with the undersides facing upward.
- ▶ Screw the two antenna splitters together using the jointing plate and the six recessed head screws, as shown in the figure.

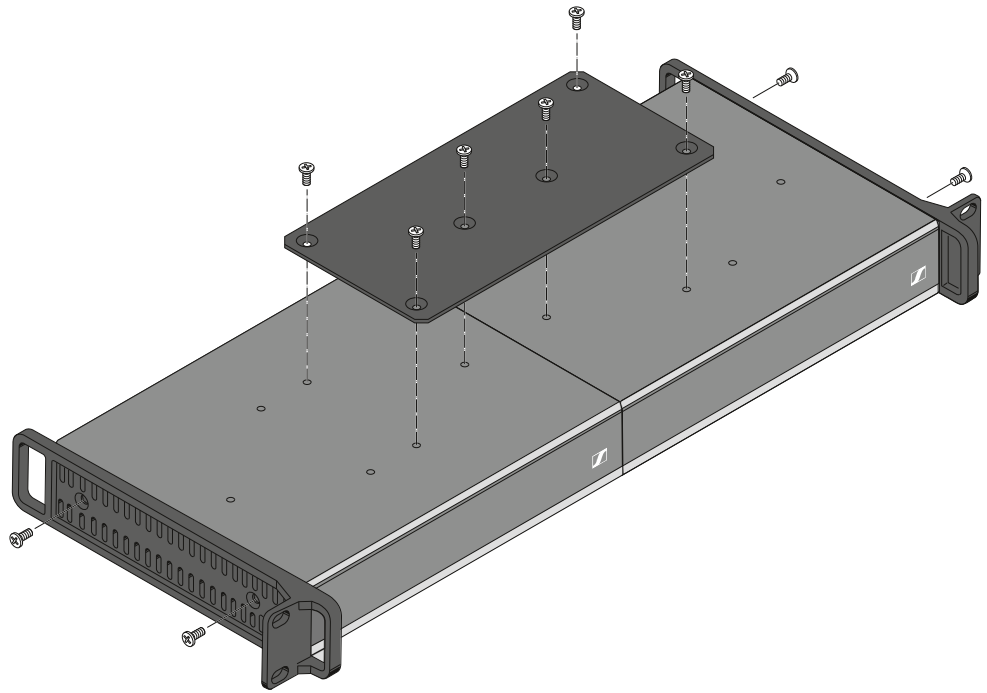

- ▶ Screw the unit consisting of the two antenna splitters into a 19" rack.



5. Regulatory Information

Information on manufacturer declarations, environmental and disposal notices, and terms of use.

Model: SL Rack Receiver DW, SL Tablestand 133-S DW, SL Tablestand 153-S DW, SL Boundary 114-S DW, SL Bodypack DW, SL Handheld DW

Conditions and restrictions for using frequencies

There may be special conditions and restrictions for using frequencies in your country.

Before putting the product into operation, find the information for your country at the following address: [sennheiser.com/sifa](https://www.sennheiser.com/sifa).

Information on cyber security

The product is designed for transmitting confidential or sensitive information.

The implemented AES-256 encryption standard ensures that your data remains protected and secure during transmission.

To ensure the security of your control data and audio data, we recommend using the product within a closed network environment.

Warranty

Sennheiser electronic SE & Co. KG gives a warranty of 24 months on these products.

For the current warranty conditions, please visit our website at [sennheiser.com](https://www.sennheiser.com) or contact your Sennheiser partner.

In the US please contact:

Sennheiser Electronic Corporation

1 Enterprise Drive, Old Lyme, CT 06371

www.sennheiser.com

Warranty for Australia and New Zealand only

Sennheiser Australia Pty Ltd provides a warranty of 24 months on these products. For the current warranty conditions, visit Sennheiser website: Australia: [sennheiser.com](https://www.sennheiser.com), New Zealand: [sennheiser.com](https://www.sennheiser.com)

Sennheiser goods come with guarantees that cannot be excluded under Australian and New Zealand Consumer law. You are entitled to a replacement or refund for a major failure and compensation for any other reasonably foreseeable loss or damage. You are also entitled



to have the goods repaired or replaced if the goods fail to be of acceptable quality and the failure does not amount to a major failure.

This warranty is in addition to other rights or remedies under law. Nothing in this warranty excludes, limits or modifies any remedy available to be consumer which is granted by law.

To make a claim under this contract, raise a case via Sennheiser website. Australia: sennheiser.com/support, New Zealand: sennheiser.com/support

All expenses of claiming the warranty will be borne by the person making the claim.

Sennheiser international warranty is provided by: Sennheiser Australia Pty Ltd (ABN 68 165 388 312) Level 14, Tower A Zenith Building, 821 Pacific Highway, Chatswood NSW 2067, Australia

Europe



In compliance with the following requirements

- Regulation (EU) 2023/988 on general product safety
- WEEE Directive (2012/19/EU)
- Regulation (EU) 2023/1542 concerning batteries and waste batteries



Italy:

Raccolta carta



Raccolta plastica



France:



FR

- Carton d'emballage
- + Film PE
- + Notice d'emploi en papier



Notes on disposal

The symbol of the crossed-out dumpster on the product, the (rechargeable) battery (if applicable) and/or the packaging indicates that these products must not be disposed of with normal household waste, but must be disposed of separately at the end of their service



life. For the packaging, follow the regulations in your country for separating waste. Improper disposal of packaging materials can be harmful to your health and the environment.

The separate collection of waste electrical and electronic equipment, (rechargeable) batteries (if applicable) and packaging is intended to promote reuse and recycling and to prevent negative impacts on public health and the environment, for example due to hazardous substances contained in these products. At the end of their service life, recycle electrical and electronic equipment and (rechargeable) batteries so that their materials can be reused and to prevent environmental pollution.

If (rechargeable) batteries can be removed without destroying them, you are obliged to dispose of them separately (see the product's operating instructions for information on how to remove the batteries safely). Be especially careful when handling (rechargeable) batteries containing lithium, as these pose special hazards, such as the risk of fire and/or health risks if button cells are swallowed. Reduce battery waste as much as possible by using longer-life batteries or rechargeable batteries.

Further information on the recycling of these products can be obtained from your municipal administration, from the municipal collection points, or from your Sennheiser partner. You may also be able to return electrical or electronic equipment to your distributor, if they are legally required to do so. By disposing of your batteries properly, you are helping to protect public health and the environment.

EU Declaration of conformity

- RoHS Directive (2011/65/EU)

Hereby, Sennheiser electronic SE & Co. KG declares that the radio equipment type SL Rack Receiver DW, SL Handheld DW, SL Bodypack DW, SL Tablestand 133-S DW, SL Tablestand 153- S DW, SL Boundary 114-S DW is in compliance with Directive 2014/53/EU.

The full text of the EU declaration of conformity is available at the following internet address: sennheiser.com/download.

United Kingdom



In compliance with the following requirements

- WEEE Regulations (2013)
- Battery Regulations (2015)





UK Declaration of conformity

- RoHS Regulations (2012)
- Radio Equipment Regulations (2017)

Importer: Sennheiser UK Ltd.

Pacific House, Third Avenue, Globe Park, Marlow

Buckinghamshire SL7 1EY, United Kingdom

USA



Statements regarding FCC and ISED

This device complies with part 15 of the FCC rules and RSS-210 of Innovation, Science and Economic Development Canada (ISED). Operation is subject to the following two conditions: (1) this device may not cause harmful interference, and (2) this device must accept any interference received, including interference that may cause undesired operation.

Changes or modifications not expressly approved by Sennheiser electronic Corp. could void the user's authority to operate the equipment.

This equipment has been tested and found to comply with the limits for a Class B digital device, pursuant to part 15 of the FCC Rules. These limits are designed to provide reasonable protection against harmful interference in a residential installation. This equipment generates, uses and can radiate radio frequency energy and, if not installed and used in accordance with the instructions, may cause harmful interference to radio communications. However, there is no guarantee that interference will not occur in a particular installation. If this equipment does cause harmful interference to radio or television reception, which can be determined by turning the equipment off and on, the user is encouraged to try to correct the interference by one or more of the following measures:

- Reorient or relocate the receiving antenna.
- Increase the separation between the equipment and receiver.
- Connect the equipment into an outlet on a circuit different from that to which the receiver is connected.
- Consult the dealer or an experienced radio/ TV technician for help.

This Class B digital device complies with the Canadian ICES-003.

Contact information: Sennheiser Electronic Corporation, 1 Enterprise Drive, Old Lyme, CT 06371; sennheiser.com

Radiofrequency radiation exposure Information

This equipment complies with FCC and IC radiation exposure limits set forth for an uncontrolled environment. The SL Rack Receiver DW should be installed and operated with a minimum distance of 20 cm between the radiator and your body.



The radiated output power of the device is far below the FCC and ISED radio frequency exposure limits. Nevertheless, the device shall be used in such a manner that the potential for human contact during normal operation is minimized.

SL Rack Receiver DW FCC ID: DMOEM1G9WE

SL Handheld DW FCC ID: DMOSKM1G9WE

SL Bodypack DW FCC ID: DMOSK1G9WE

SL Tablestand 133-S DW FCC ID: DMOTS1G9WE

SL Tablestand 153-S DW FCC ID: DMOTS1G9WE

SL Boundary 114-S DW FCC ID: DMOB1G9WE

Canada

Statements regarding FCC and ISED

This device complies with part 15 of the FCC rules and RSS-210 of Innovation, Science and Economic Development Canada (ISED). Operation is subject to the following two conditions: (1) this device may not cause harmful interference, and (2) this device must accept any interference received, including interference that may cause undesired operation.

Changes or modifications not expressly approved by Sennheiser electronic Corp. could void the user's authority to operate the equipment.

This equipment has been tested and found to comply with the limits for a Class B digital device, pursuant to part 15 of the FCC Rules. These limits are designed to provide reasonable protection against harmful interference in a residential installation. This equipment generates, uses and can radiate radio frequency energy and, if not installed and used in accordance with the instructions, may cause harmful interference to radio communications. However, there is no guarantee that interference will not occur in a particular installation. If this equipment does cause harmful interference to radio or television reception, which can be determined by turning the equipment off and on, the user is encouraged to try to correct the interference by one or more of the following measures:

- Reorient or relocate the receiving antenna.
- Increase the separation between the equipment and receiver.
- Connect the equipment into an outlet on a circuit different from that to which the receiver is connected.
- Consult the dealer or an experienced radio/ TV technician for help.

This Class B digital device complies with the Canadian ICES-003.

Contact information: Sennheiser Electronic Corporation, 1 Enterprise Drive, Old Lyme, CT 06371; sennheiser.com

Radiofrequency radiation exposure Information



This equipment complies with FCC and IC radiation exposure limits set forth for an uncontrolled environment. The SL Rack Receiver DW should be installed and operated with a minimum distance of 20 cm between the radiator and your body.

The radiated output power of the device is far below the FCC and ISED radio frequency exposure limits. Nevertheless, the device shall be used in such a manner that the potential for human contact during normal operation is minimized.

CAN ICES-003(B)/NMB-003(B)

SL Rack Receiver DW IC: 2099A-EM1G9WE

SL Handheld DW IC: 2099A-SKM1G9WE

SL Bodypack DW IC: 2099A-SK1G9WE

SL Tablestand 133-S DW IC: 2099A-TS1G9WE

SL Tablestand 153-S DW IC: 2099A-TS1G9WE

SL Boundary 114-S DW IC: 2099A-B1G9WE

SL Tablestand 133-S DW, SL Tablestand 153-S DW, SL Boundary 114-S DW:



Australia / New Zealand



Japan



SL Rack Receiver DW	R	202-SMC048
SL Handheld DW	R	202-SMC049
SL Bodypack DW	R	202-SMC050
SL Tablestand 133-S DW	R	202-LSE099
SL Tablestand 153-S DW	R	202-LSE099
SL Boundary 114-S DW	R	202-SMF039

日本の電波法に準拠

本機器は、日本の電波法に準拠しています。



本機器を改変しないでください（守らない場合、付与された指定番号が無効になります）。

Japanese Radio Law Compliance

This device is granted pursuant to the Japanese Radio Law (電波法).

This device should not be modified (otherwise the granted designation number will become invalid).

Argentina

SL Rack Receiver DW

R!C-15661

SL Handheld DW

R!C-15662

SL Bodypack DW

R!C-15663

Brazil



CMV SEBR COMERCIO DE ELETRONICOS LTDA

SL Rack Receiver DW 04862-20-07356

SL Handheld DW 07419-20-07356



SL Bodypack DW 10814-20-07356

SL Tablestand 133-S DW 07826-18-07356

SL Tablestand 153-S DW 07826-18-07356

SL Boundary 114-S DW 08848-18-07356

India

SL Tablestand 133-S DW, SL Tablestand 153-S DW, SL Boundary 114-S DW, SL Bodypack DW, SL Handheld DW

IS 616/IEC 60065



R-41196606
www.bis.gov.in

Mexico

SL Rack Receiver DW RTISESL15-2238-A1



SL Handheld DW RTISESL15-2240

SL Bodypack DW RTISESL15-2239-A1



Malaysia



SL Rack Receiver DW RBAB/65G/0517/ S(17-1181)

SL Handheld DW RDDA/20A/0517/ S(17-1452)

SL Bodypack DW RDDA/04A/0517/ S(17-1453)

SL Tablestand 133-S DW RDDG/03A/0517/ S(17-1617)

SL Tablestand 153-S DW RDDG/02A/0517/ S(17-1618)

SL Boundary 114-S DW RBEU/02A/0817/ S(17-2620)

Vietnam

Kể từ ngày 1 tháng 12 năm 2012, các sản phẩm được sản xuất bởi Sennheiser tuân thủ Thông tư 30/2011/TT-BCT quy định về giới hạn cho phép đối với một số chất độc hại trong các sản phẩm điện và điện tử.

Taiwan

SL Rack Receiver DW  CCAB16E10020T9

SL Handheld DW  CCAB16E10030T2



SL Bodypack DW  CCAB16E10080T1

SL Tablestand 133-S DW  CCAB17E1016AT9

SL Tablestand 153-S DW  CCAB17E10160T7

SL Boundary 114-S DW  CCAB17E10170T0

China

SL Rack Receiver DW, SL Tablestand 133-S DW, SL Tablestand 153-S DW, SL Boundary 114-S DW, SL Bodypack DW, SL Handheld DW:

China RoHS

部件名称 (Parts)	有害物质										产品环保年限 EFUP
	铅 (Pb)	汞 (Hg)	镉 (Cd)	六价铬 (Cr6+)	多溴联苯 (PBB)	多溴二苯醚 (PBDE)	邻苯二甲酸二 (2-乙基己)酯 (DEHP)	邻苯二甲 酸丁苯酯 (BBP)	邻苯二甲 酸二丁酯 (DBP)	邻苯二甲 酸二异丁酯 (DIBP)	
金属部件 (Metal parts)	x	o	o	o	o	o	o	o	o	o	15
电路模块 (Circuit Modules)	x	o	o	o	o	o	o	o	o	o	15
电缆及电缆组件 (Cables & Cable Assemblies)	x	o	o	o	o	o	o	o	o	o	15
外部电力适配器 - 如果包含 (external power supply - if available)	x	o	o	o	o	o	o	o	o	o	10

本表格依据 SJ/T 11364 的规定编制。
 o: 表示该有害物质在该部件所有均质材料中的含量均在 GB/T 26572 规定的限量要求以下。
 x: 表示该有害物质至少在该部件的某一均质材料中的含量超出 GB/T 26572 规定的限量要求。

SL MCR DW:

China RoHS

部件名称 (Parts)	有害物质										产品环保年限 EFUP
	铅 (Pb)	汞 (Hg)	镉 (Cd)	六价铬 (Cr6+)	多溴联苯 (PBB)	多溴二苯醚 (PBDE)	邻苯二甲酸二 (2-乙基己)酯 (DEHP)	邻苯二甲 酸丁苯酯 (BBP)	邻苯二甲 酸二丁酯 (DBP)	邻苯二甲 酸二异丁酯 (DIBP)	
金属部件 (Metal parts)	x	o	o	o	o	o	o	o	o	o	15
电路模块 (Circuit Modules)	x	o	o	o	o	o	o	o	o	o	15

本表格依据 SJ/T 11364 的规定编制。
 o: 表示该有害物质在该部件所有均质材料中的含量均在 GB/T 26572 规定的限量要求以下。
 x: 表示该有害物质至少在该部件的某一均质材料中的含量超出 GB/T 26572 规定的限量要求。



6. Contact

Contact information in case of questions about our products and/or services.



