



# Headworn microphones

For clear speech and maximum mobility

PDF export of the original HTML manual



## Contents

1. Preface.....	3
2. Product information.....	4
Product overview.....	4
Delivery includes.....	10
Accessories.....	12
3. Instruction manual.....	13
Headmic 1.....	13
Headmic 4.....	18
HS 2.....	23
HSP 2.....	26
HSP Essential.....	32
ME 3.....	35
Cleaning and maintenance.....	37
4. Specifications.....	39
5. Regulatory information.....	50



# 1. Preface

## **PDF Export of the Original HTML Manual**

This PDF document is an automatic export of an interactive set of HTML manuals. Some content and interactive elements may not be included in the PDF because they cannot be displayed in this format. In addition, automatically generated page breaks may cause related content to be slightly shifted. We can therefore only guarantee the completeness of the information in the HTML manual and recommend using it. You can find it in the Documentation Portal at [www.sennheiser.com/documentation](http://www.sennheiser.com/documentation).



## 2. Product information

All information about the headworn microphones and available accessories at a glance.

### Product overview

Information about the products and their variants.

#### Headmic 1



Variant	Connector	Art. no.
Headmic 1 (Black EW)	3.5 mm jack	506271
Headmic 1 (Beige EW)	3.5 mm jack	506272
Headmic 1 (Silver EW)	3.5 mm jack	506904
Headmic 1 (Black 3-Pin)	3-pin	506905
Headmic 1 (Beige 3-Pin)	3-pin	506906
Headmic 1 (Silver 3-Pin)	3-pin	506907



**i** You can find more detailed information about the Headmic 1 in the following sections:

- **Startup and operation:** [Headmic 1](#)
- **Specifications:** [Headmic 1](#)

## Headmic 4

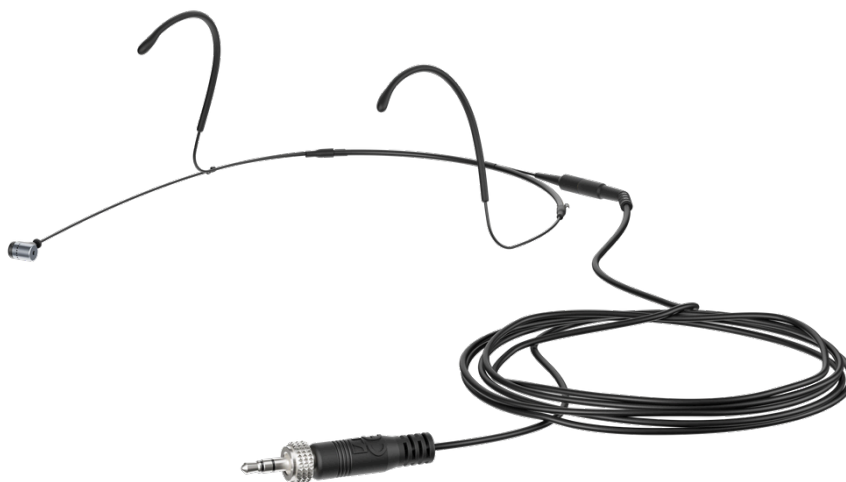

Variant	Connector	Art. no.
Headmic 4 (Beige EW)	3.5 mm jack	509494
Headmic 4 (Black EW)	3.5 mm jack	509495
Headmic 4 (Silver EW)	3.5 mm jack	509496
Headmic 4 (Beige 3-Pin)	3-pin	509497
Headmic 4 (Black 3-Pin)	3-pin	509498
Headmic 4 (Silver 3-Pin)	3-pin	509499

**i** You can find more detailed information about the Headmic 4 in the following sections:

- **Startup and operation:** [Headmic 4](#)
- **Specifications:** [Headmic 4](#)



## HS 2



Variant	Connector	Art. no.
HS 2 (Beige EW)	3.5 mm jack	508882
HS 2 (Black EW)	3.5 mm jack	508883
HS 2 (Beige 3-Pin)	3-Pin	508884
HS 2 (Black 3-Pin)	3-Pin	508885

**i** You can find more detailed information about the HS 2 in the following sections:

- **Startup and operation:** [HS 2](#)
- **Specifications:** [HS 2](#)



## HSP 2



Variant	Connector	Art. no.
HSP 2 (Black 3-Pin)	3-pin	009862
HSP 2 (Beige 3-Pin)	3-pin	009863
HSP 2 (Black EW)	3.5 mm jack	009866
HSP 2 (Beige EW)	3.5 mm jack	009872

**i** You can find more detailed information about the HSP 2 in the following sections:

- **Startup and operation:** [HSP 2](#)
- **Specifications:** [HSP 2](#)



## HSP Essential



Variant	Connector	Art. no.
HSP Essential (Black EW)	3.5 mm jack	508245
HSP Essential (Beige EW)	3.5 mm jack	508246
HSP Essential (Black 3-Pin)	3-pin	508247
HSP Essential (Beige 3-Pin)	3-pin	508248

**i** You can find more detailed information about the HSP Essential in the following sections:

- **Startup and operation:** [HSP Essential](#)
- **Specifications:** [HSP Essential](#)

## ME 3



ME 3 | 3.5 mm jack | Art. no. 508928



**i** You can find more detailed information about the ME 3 in the following sections:

- **Startup and operation:** [ME 3](#)
- **Specifications:** [ME 3](#)



## Delivery includes

### Headmic 1

- Headmic 1
- Connection cable
- MZC 1-2 frequency response cap
- SL MZW 1 windshield
- Soft case
- Quick Guide
- Safety Guide

### Headmic 4

- Headmic 4
- Connection cable
- MZW 44 windshield
- Soft case
- Quick Guide
- Safety Guide

### HS 2

- HS 2
- headband
- MZC 2-1 frequency cap, short
- MZC 2-2 frequency cap, long
- Quick Guide
- Safety Guide

### HSP 2

- HSP 2
- Neckband
- Microphone boom
- Clips for attaching the microphone boom
- Connection cable
- Plastic transport case, foam-lined with cut-outs
- Caps for altering the frequency response
- Quick Guide
- Safety Guide



### **HSP Essential**

- HSP Essential
- SL MZW 1 windshield
- Bag
- Quick Guide
- Safety Guide

### **ME 3**

- ME 3
- Windshield
- Bag
- Quick Guide
- Safety Guide



## Accessories

### **MZW 2**

Basket windshield for HS 2 and HSP 2

Art. no. 543658

### **MZW 02**

Foam windshield for the MKE 2

Art. no. 578819

### **MZQ 02**

Clamp for Headmic 1 and Headmic 4

Art. no. 543653 (black) | Art. no. 577719 (beige)



### 3. Instruction manual

Information about starting up, operating and cleaning the microphones.

#### Headmic 1

To change the microphone position:

##### NOTICE



##### Damage to the microphone boom

The microphone boom can break or be impaired in its function when you bend or turn it. Also avoid frequent alternate bendings close to the microphone head as this can also damage the microphone boom and possibly reduce the adjustability of the microphone.

- ▶ Only adjust the microphone boom as described in this chapter.

- ▶ First remove the microphone boom from the three clips.
- ▶ By turning the microphone boom, remove it from the fourth clip.

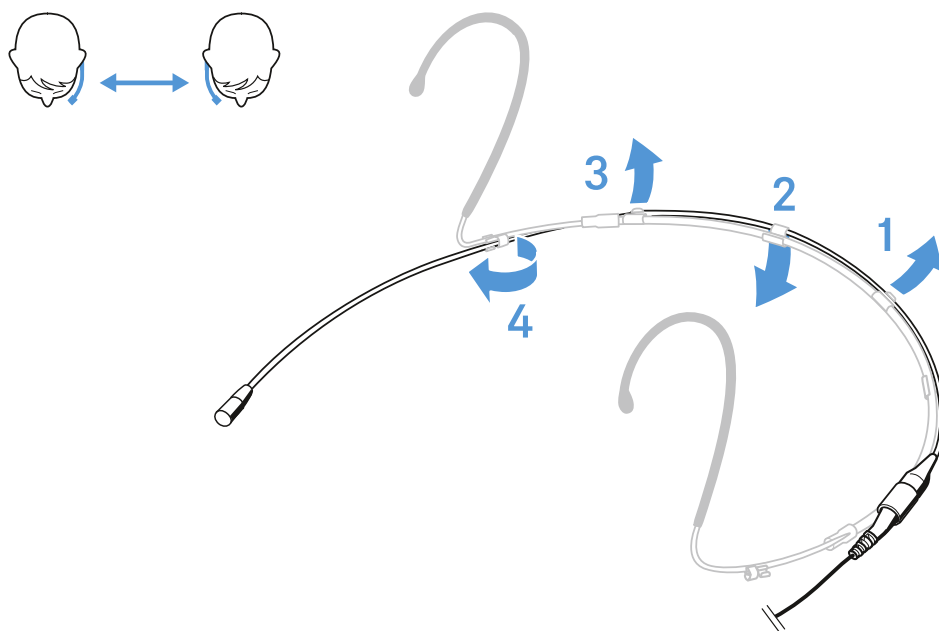

- ▶ First attach the end of the microphone boom where the microphone head is fitted to the clip on the desired side of the neckband.



- ▶ Press the microphone boom into the three clips.

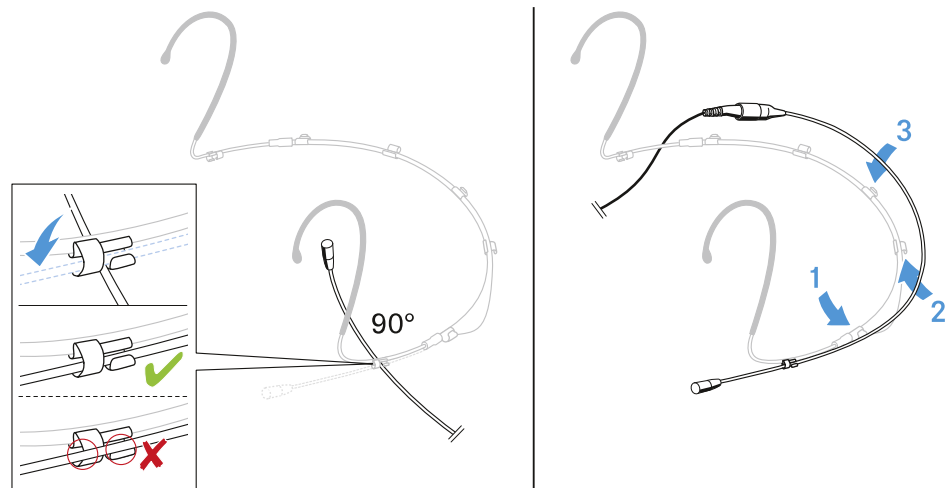

**To use the frequency response caps:**

- i** The frequency response caps allows you to adjust the microphones sensitivity in the presence area (see specifications [Headmic 1](#)).

- ▶ Slip the frequency response cap (depending on the model, included in the scope of delivery or available as an optional accessory) onto the microphone until it locks into place with an audible click.

MZC 1-2



+ 4 dB

MZC 1-1



+ 2 dB

or



**To adjust the microphone:**

- ▶ If necessary, adjust the size of the neckband by moving the ear hooks.

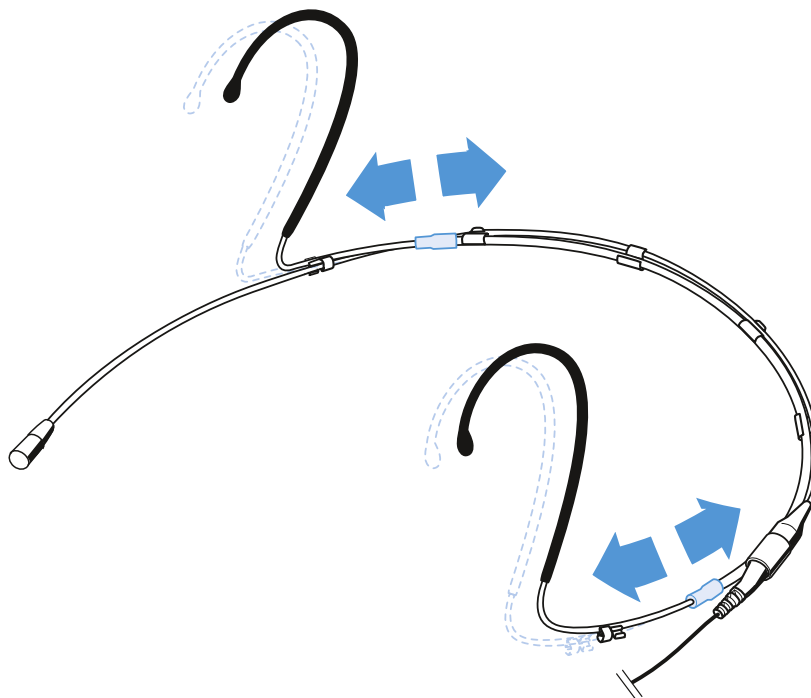

- ▶ If necessary, gently bend the ear hook.

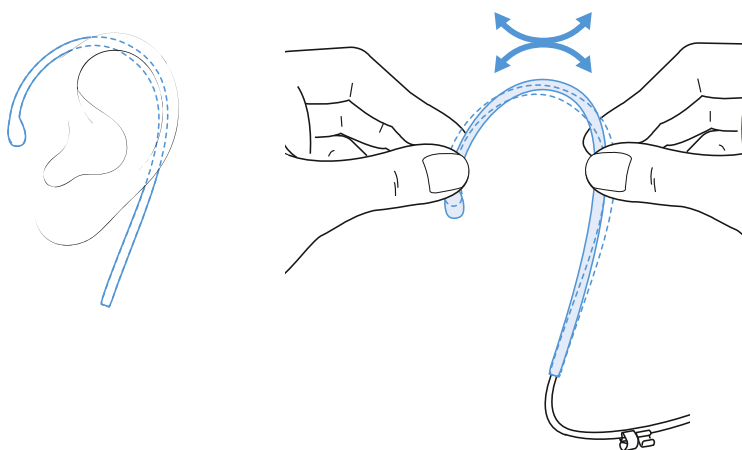



**To position the microphone:**

- ▶ Carefully bend the microphone boom (**not the microphone head**) so that the microphone is positioned next to the mouth.

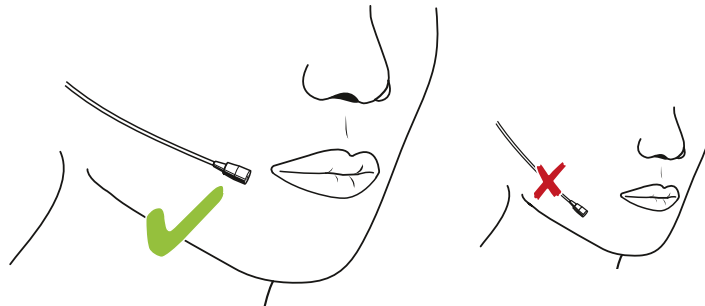
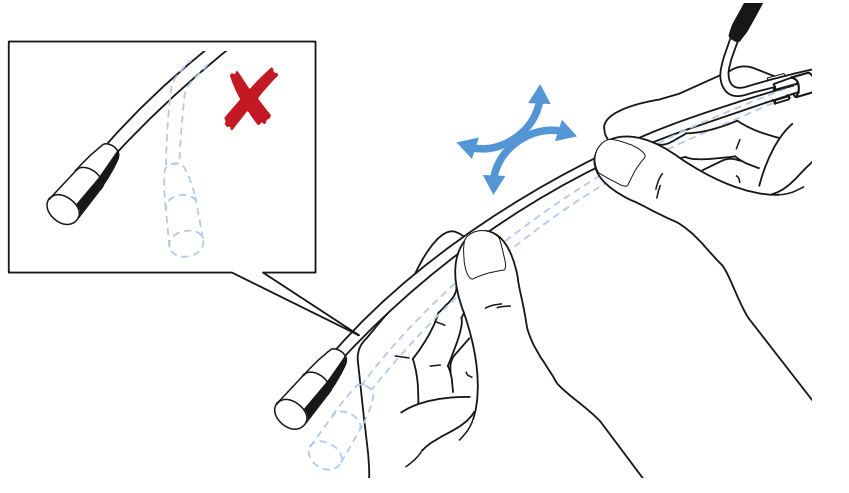



**To use the windshield:**

- ▶ Slide the windshield SLMZW 1 over the microphone head.

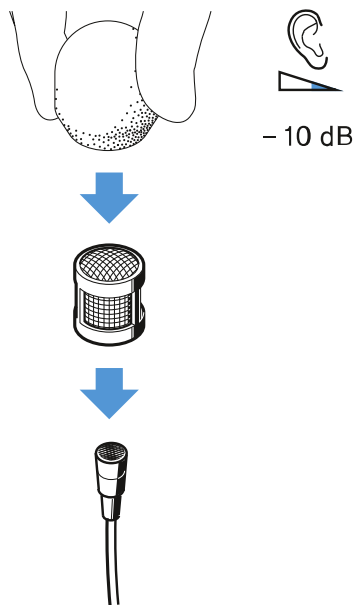

**To attach the microphone to a clip:**

- ▶ Attach the microphone to the clip **MZQ 02** (optional accessory) as shown in the illustration.

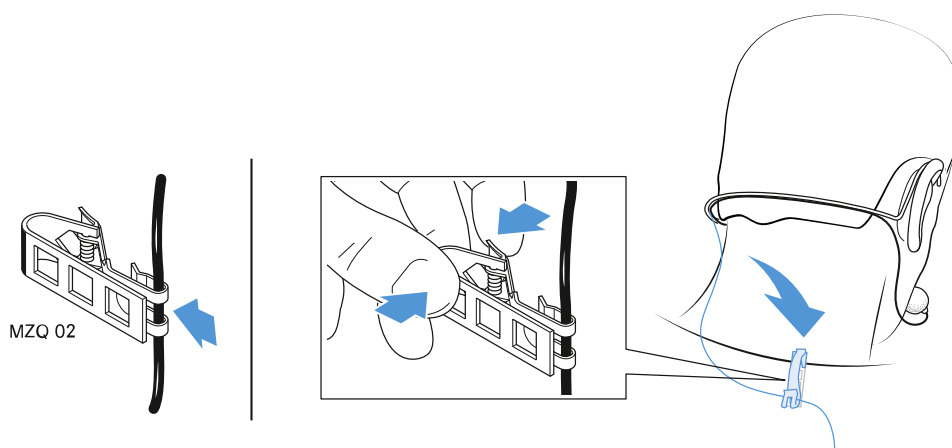



## Headmic 4

To connect the headworn microphone with the cable:

- ▶ Plug the connector into the socket.
- ▶ Slide the silicone tube onto the connector.

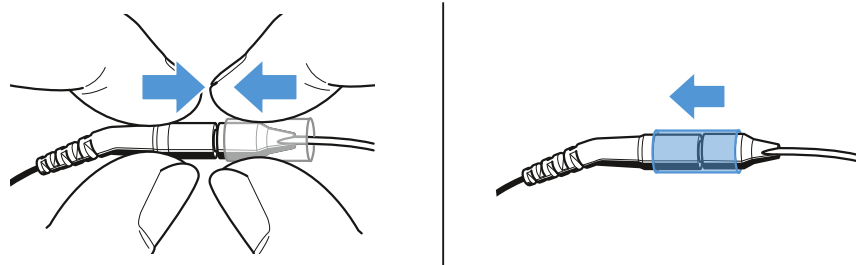

To change the microphone position:

### NOTICE



#### Damage to the microphone boom

The microphone boom can break or be impaired in its function when you bend or turn it. Also avoid frequent alternate bendings close to the microphone head as this can also damage the microphone boom and possibly reduce the adjustability of the microphone.

- ▶ Only adjust the microphone boom as described in this chapter.

- ▶ Remove the microphone boom from the neckband as shown in the illustration.

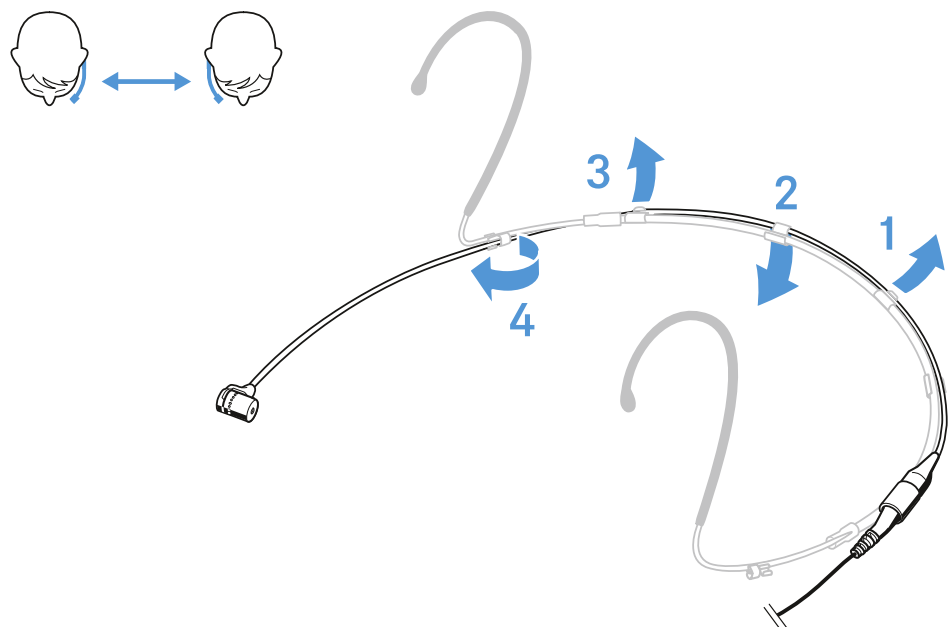



- ▶ Insert the microphone boom into the neckband as shown in the illustration.

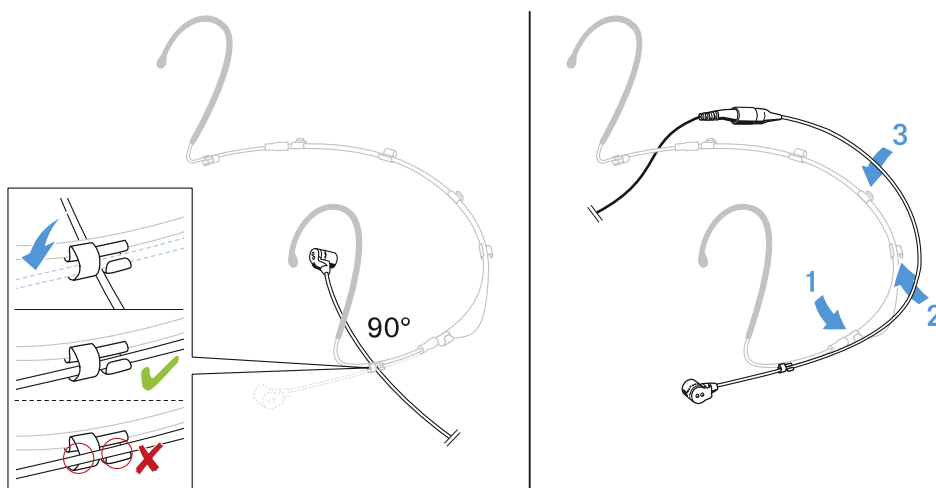

**To connect the microphone:**

- ▶ Insert the cable's plug into the socket of the bodypack transmitter.
- ▶ Screw the plug's coupling ring onto the audio socket thread of the bodypack transmitter.

3.5 mm jack plug

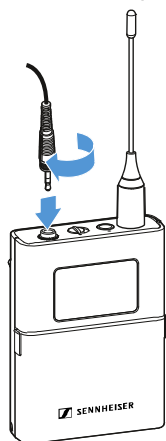

or

3-Pin connector

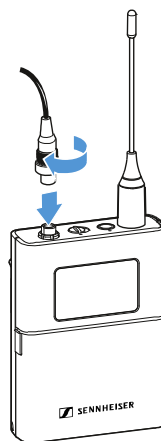



**To adjust the microphone:**

- ▶ If necessary, adjust the size of the neckband by moving the ear hooks.

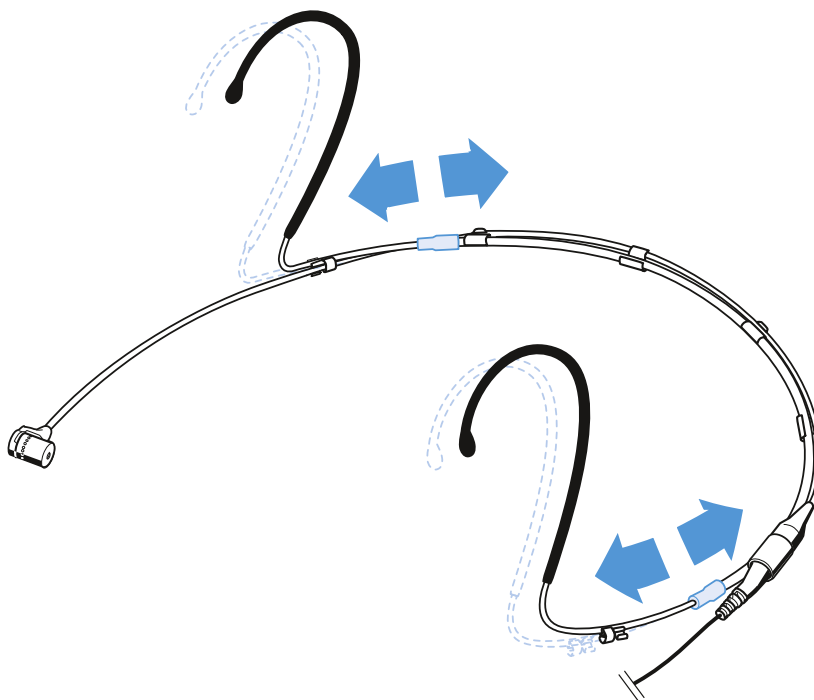

- ▶ If necessary, gently bend the ear hook.

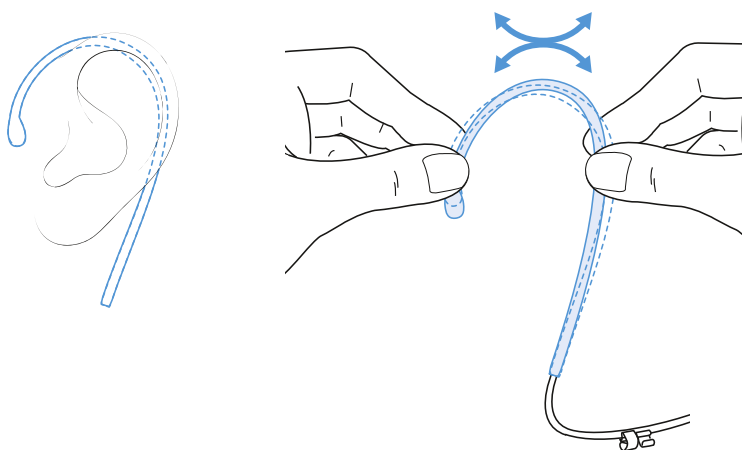



**To position the microphone:**

- ▶ Carefully bend the microphone boom (**not the microphone head**) so that the microphone is positioned next to the mouth.

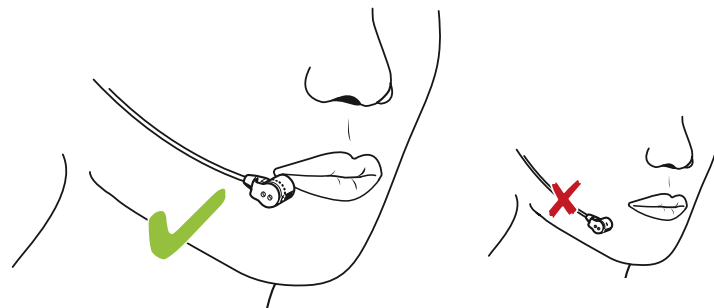
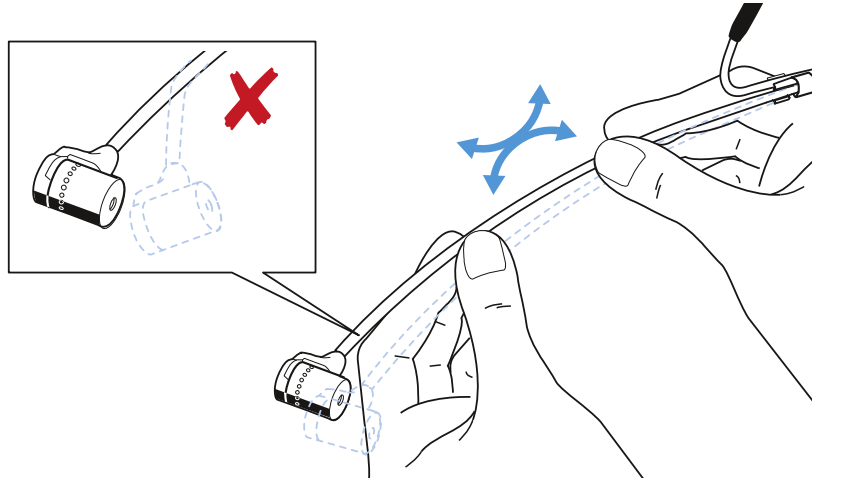

**To use the windshield:**

- ▶ Slide the windshield MZW 44 over the microphone head.

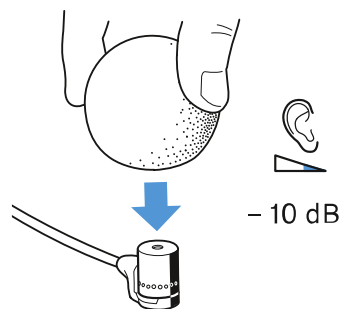



**To attach the microphone to a clip:**

- ▶ Attach the microphone to the clip **MZQ 02** (optional accessory) as shown in the illustration.

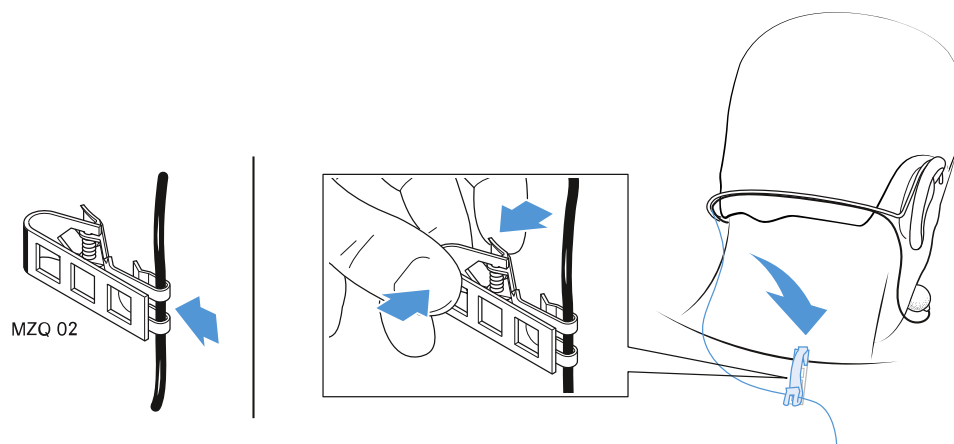

**To transport the microphone:**

- ▶ Slide the silicone tube aside.
- ▶ Pull the connector and the socket apart.
- ▶ Place the microphone and the cable separately into the soft case.

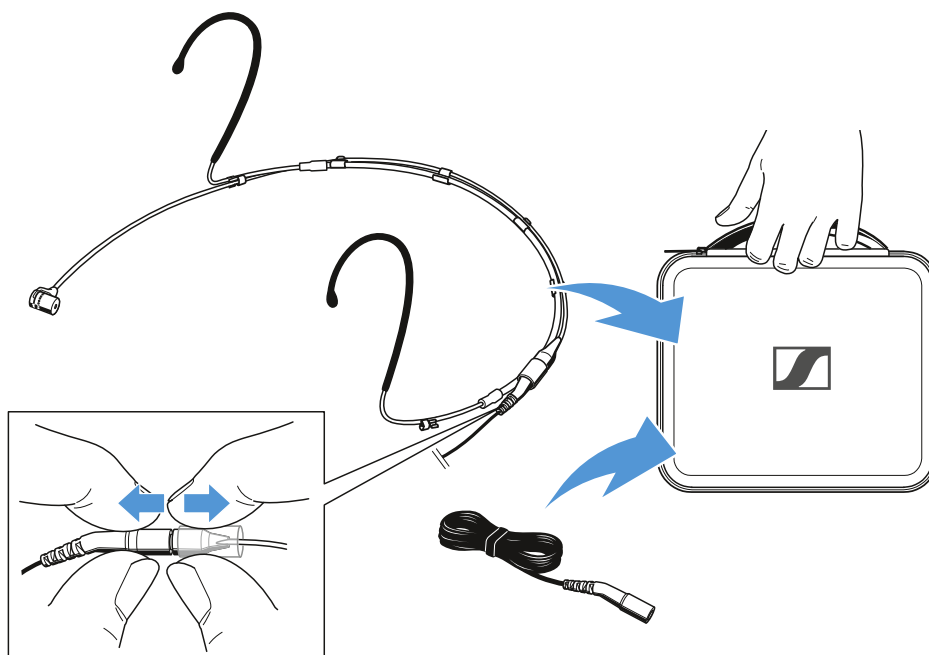



## HS 2

### To attach the headband:

- ▶ Slide the ends of the headband into the bracket until they audibly click into place.
- ▶ Make sure the headband sits below the bracket.

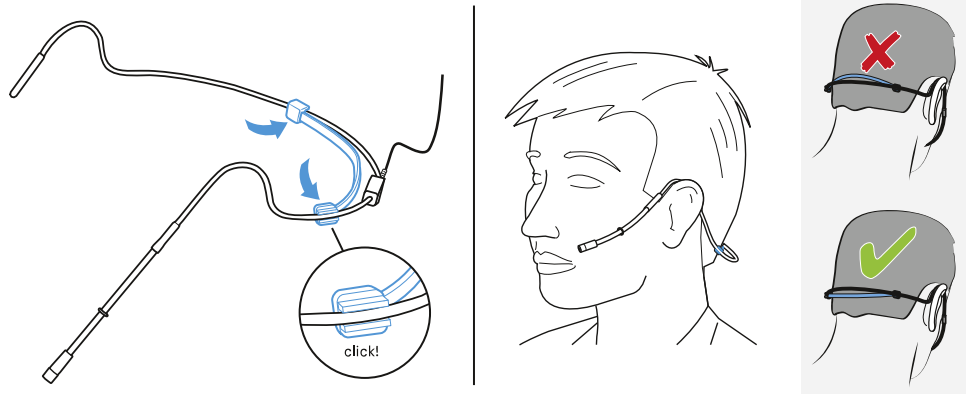

### To use the frequency response caps:

**i** The frequency response caps allows you to adjust the microphones sensitivity in the presence area (see specifications [HS 2](#)).

- ▶ Slip the frequency response cap onto the microphone until it locks into place with an audible click.

MZC 2-1

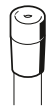

+ 2 dB

MZC 2-2

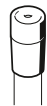

+ 4 dB

or



**To connect the microphone:**

- ▶ Insert the cable's plug into the socket of the bodypack transmitter.
- ▶ Screw the plug's coupling ring onto the audio socket thread of the bodypack transmitter.

3.5 mm jack plug

3-Pin connector

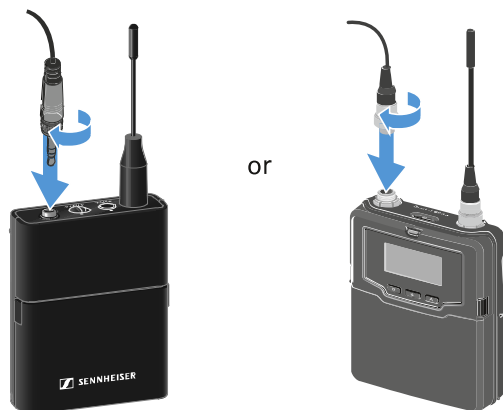

**To adjust the microphone:**

- ▶ If necessary, gently bend the neckband.

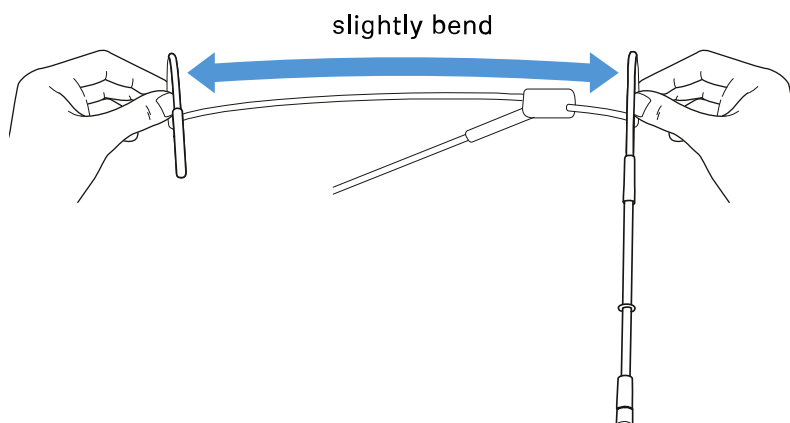

- ▶ If necessary, gently bend the ear hook.

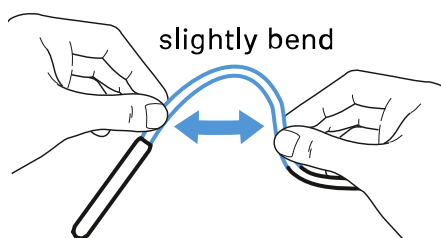



**To position the microphone:**

- ▶ Slide the microphone boom forward or backward in the clips so that the microphone is 2 to 3 cm from the corner of your mouth.



**To use the windshield:**

- ▶ Slide the windshield (optional accessory) over the microphone head.

MZW 2



- 20 dB  
MZW 2

MZW 02

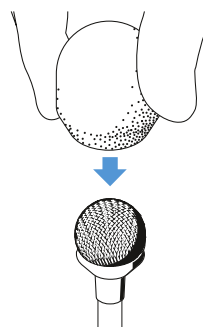

- 30 dB  
MZW 2 + MZW 02



## HSP 2

To change the microphone position:

### NOTICE



#### Damage to the microphone boom

The microphone boom can break or be impaired in its function when you bend or turn it. Also avoid frequent alternate bendings close to the microphone head as this can also damage the microphone boom and possibly reduce the adjustability of the microphone.

- ▶ Only adjust the microphone boom as described in this chapter.

- ▶ Open the clip.

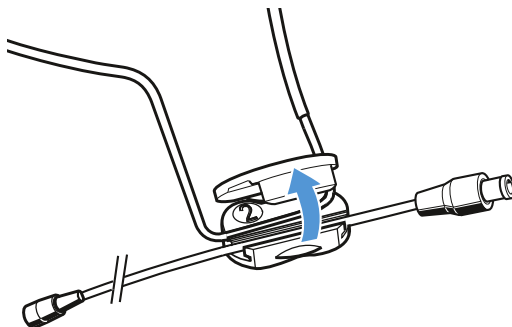

- ▶ Remove the microphone boom.

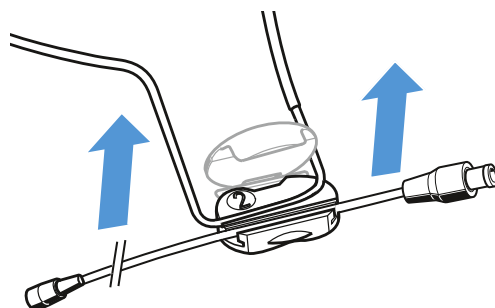

- ▶ Remove the ear hook.

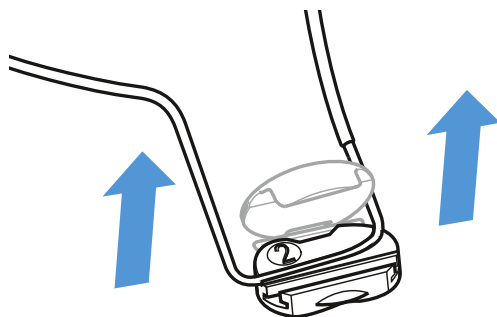

- ▶ Insert the microphone boom the other way around.

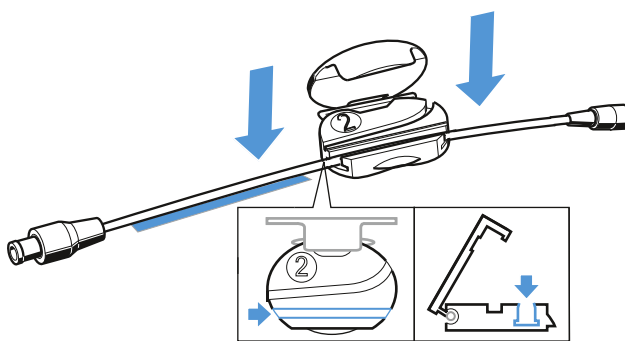

- ▶ Slide the microphone boom in the correct position.

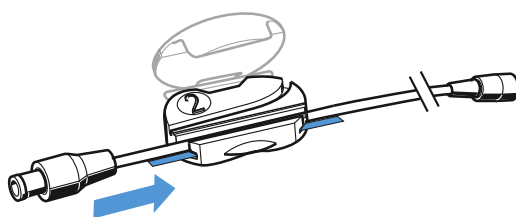

- ▶ Insert the ear hook.

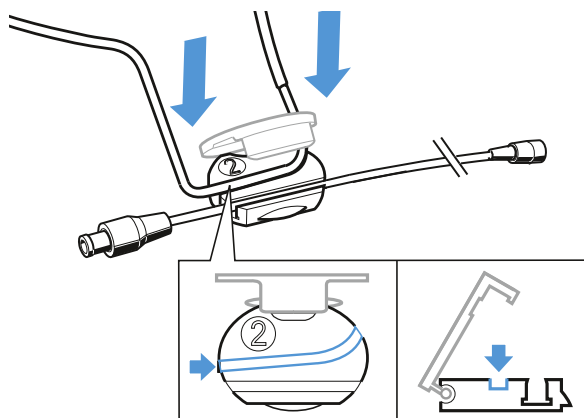

▶ Close the clip.

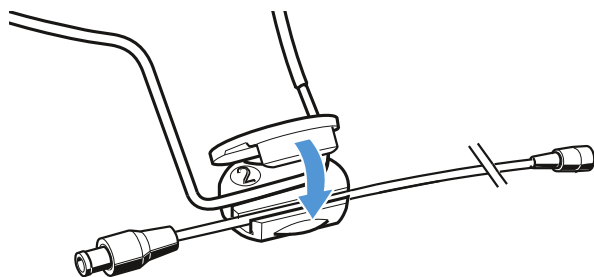



**To use the frequency response caps:**

**i** The frequency response caps allows you to adjust the microphones sensitivity in the presence area (see specifications [HSP 2](#)).

- ▶ Slip the frequency response cap onto the microphone until it locks into place with an audible click.

MZC 2-1

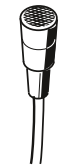

+ 2 dB

or

MZC 2-2

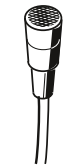

+ 4 dB

**To connect the microphone:**

- ▶ Insert the cable's plug into the socket of the bodypack transmitter.
- ▶ Screw the plug's coupling ring onto the audio socket thread of the bodypack transmitter.

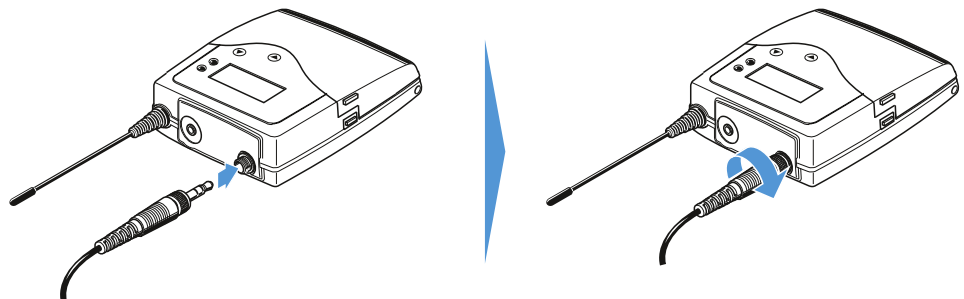

**To adjust the microphone:**

- ▶ If necessary, gently move the neckband.
- ▶ Press the cable into the clip.

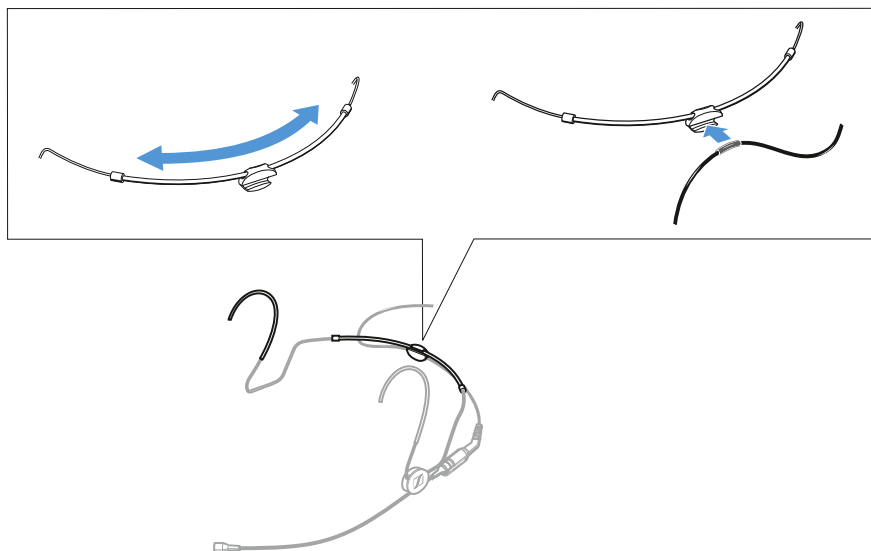

► If necessary, gently bend the ear hook.

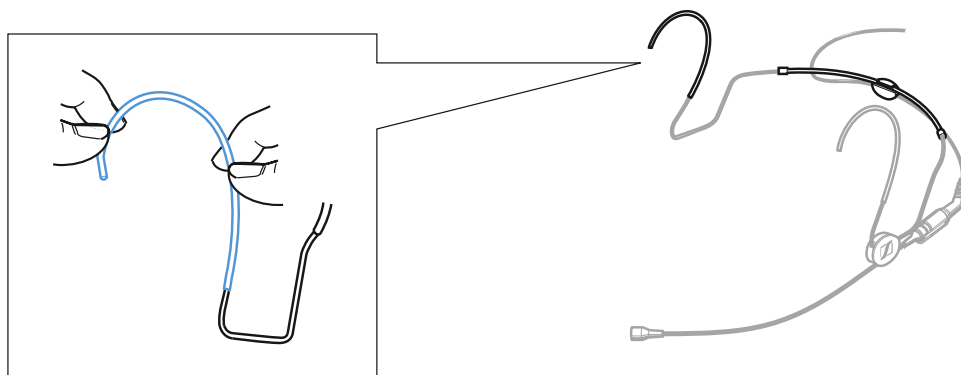



**To position the microphone:**

- ▶ Push the microphone boom in backwards or forwards in the clips so that the microphone is positioned 2 to 3 cm from the corner of the mouth.
- ▶ Move the ear hooks for a snug fit.

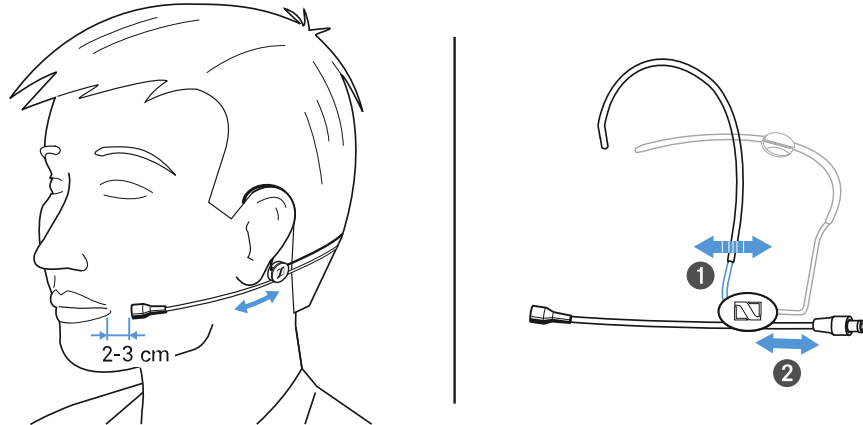

**To use the windshield:**

- ▶ Slide the windshield (optional accessory) over the microphone head.

**MZW 2**



- 20 dB  
MZW 2

**MZW 02**

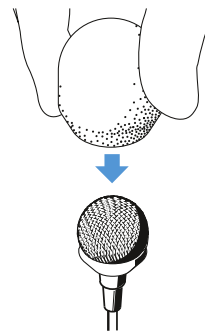

- 30 dB  
MZW 2 + MZW 02



## HSP Essential

To change the microphone position:

### NOTICE



#### Damage to the microphone boom

The microphone boom can break or be impaired in its function when you bend or turn it. Also avoid frequent alternate bendings close to the microphone head as this can also damage the microphone boom and possibly reduce the adjustability of the microphone.

- ▶ Only adjust the microphone boom as described in this chapter.

- ▶ Remove the microphone boom from the neckband as shown in the illustration.

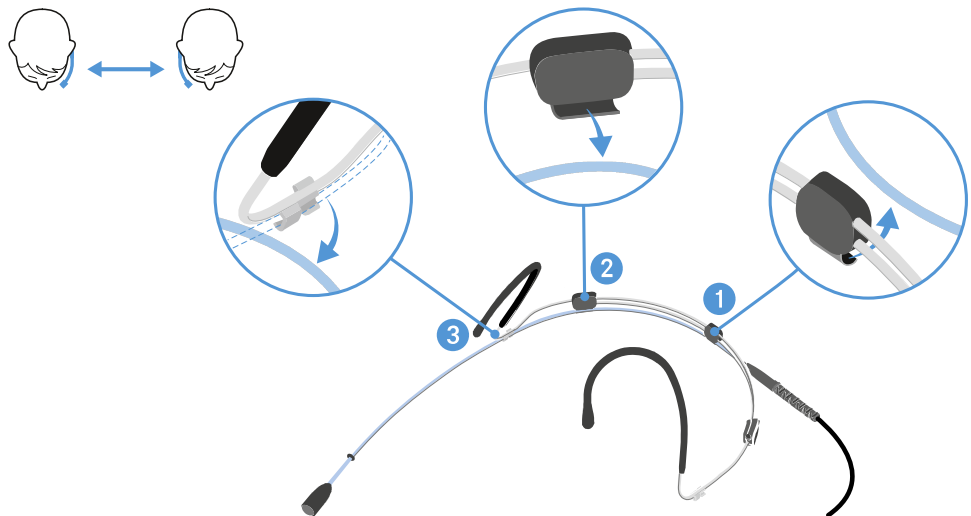

- ▶ Inset the microphone boom into the neckband as shown in the illustration.

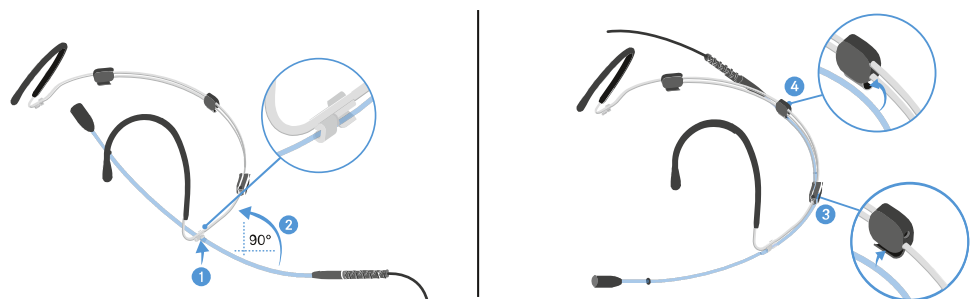



**To connect the microphone:**

- ▶ Insert the cable's plug into the socket of the bodypack transmitter.
- ▶ Screw the plug's coupling ring onto the audio socket thread of the bodypack transmitter.

3.5 mm jack plug

3-Pin connector



or



**To adjust the microphone:**

- ▶ If necessary, gently move the neckband.
- ▶ Do **not** bend the microphone boom.

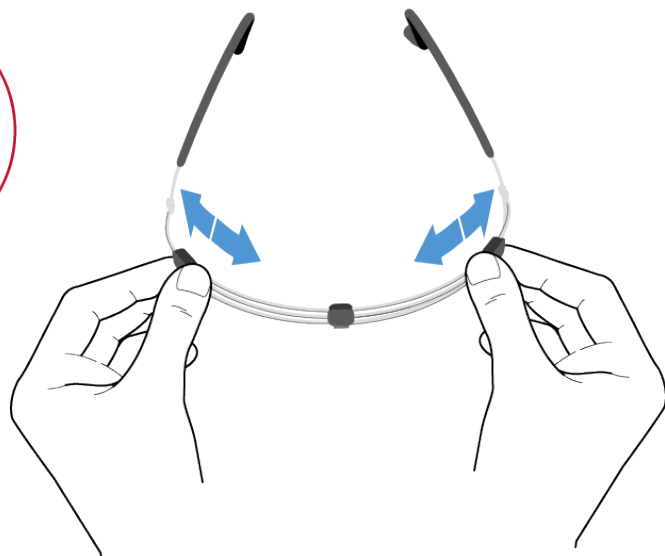



**To position the microphone:**

- ▶ Push the microphone boom in backwards or forwards in the clips so that the microphone is positioned 2 to 3 cm from the corner of the mouth.

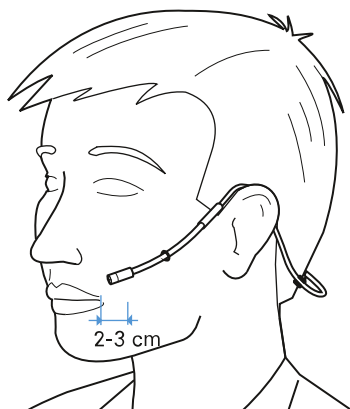

**To use the windshield:**

- ▶ Slide the windshield over the microphone head.

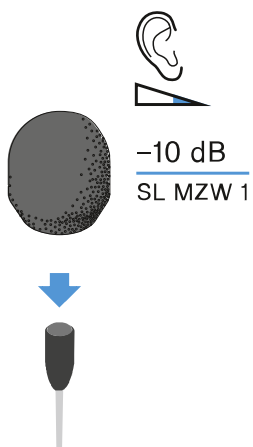



## ME 3

### To connect the microphone:

- ▶ Insert the cable's plug into the socket of the bodypack transmitter.
- ▶ Screw the plug's coupling ring onto the audio socket thread of the bodypack transmitter.

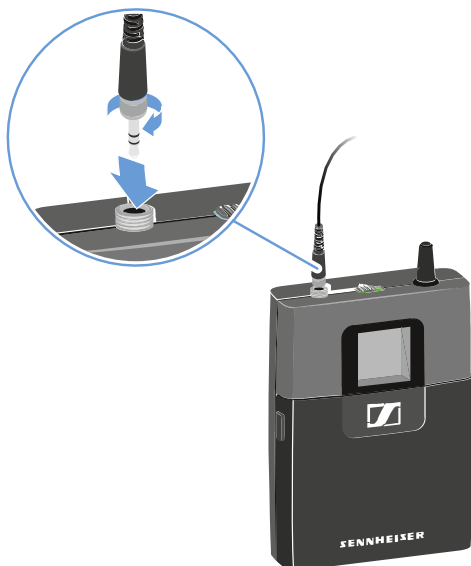

### To position the microphone:

- ▶ Position the headband at the back of the head.

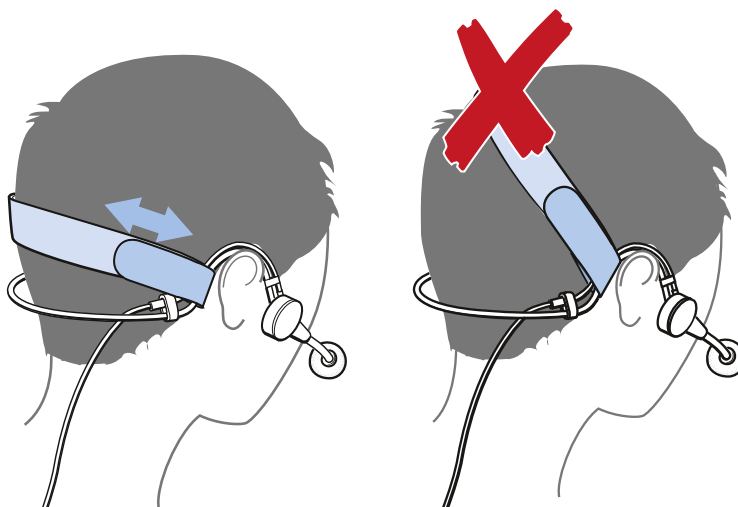



- ▶ Position the microphone so that it sits 2 to 3 cm from the corner of the mouth.

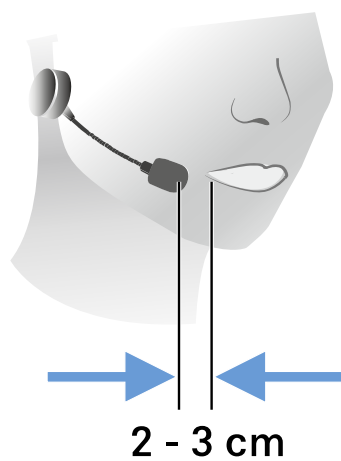

**To use the windshield:**

- ▶ Slide the windshield over the microphone head.

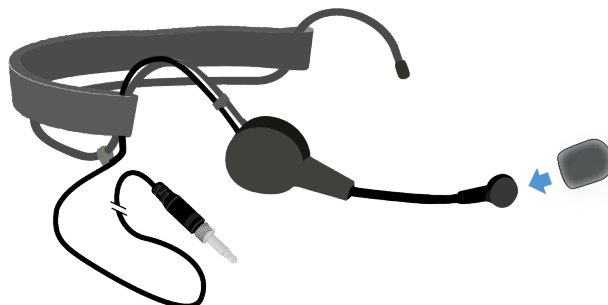



## Cleaning and maintenance

Note the following information when cleaning and maintaining the products.

### NOTICE



#### Liquids can damage the electronics of the product

Liquids entering the product housing can cause a short-circuit and damage the electronics.

- ▶ Keep all liquids away from the products.
- ▶ Do not use any solvents or cleansing agents.
- ▶ Disconnect the mains-operated products from the power supply system and remove rechargeable batteries and batteries (if present) before you begin cleaning.
- ▶ Clean all products only with a soft, dry cloth.

- ▶ Note the special cleaning instructions below for the following products.

#### To clean the frequency response caps:

- ▶ carefully pull the frequency response cap from the capsule.
- ▶ Carefully brush off the frequency response cap.



#### To clean the contacts of the connection cable:

**i** Applies to HSP 2, Headmic 4 and Headmic 1

- ▶ Slide the silicone tube aside.
- ▶ If necessary, insert your fingernail into the join.
- ▶ Pull the connector and the socket apart.



- ▶ Carefully brush off the connector and the socket.

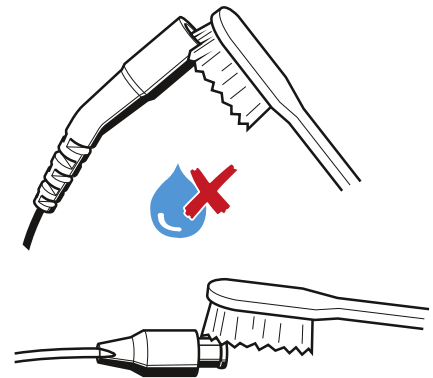
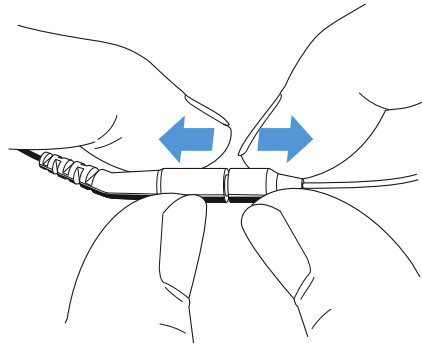
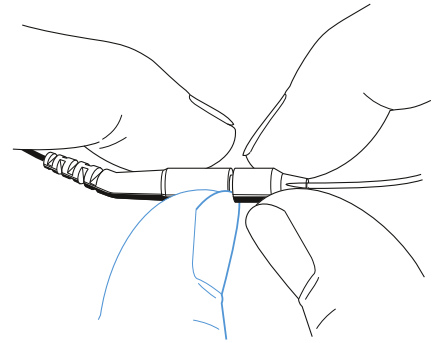
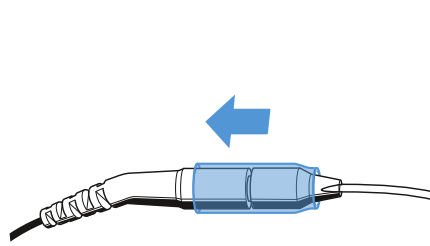



## 4. Specifications

All specifications at a glance.

### Headmic 1

#### Frequency response

- 20 - 20,000 Hz  $\pm$  3 dB

#### Pick-up pattern

- Omni-directional

#### Nominal impedance bei 1 kHz

- 1 k $\Omega$

#### Min. terminating impedance

- 4.7 k $\Omega$

#### Sensitivity

- 5 mV/Pa  $\pm$  3 dB

#### Diameter of mic capsule

- 3.3 mm

#### Max. sound pressure level

- 143 dB

#### Equivalent noise level

- 27 dB(A)

#### Supply current

- Approx. 240  $\mu$ A

#### Power supply

- 4.5 - 15 V

#### Temperature range

- Operation: -10 °C to +50 °C
- Storage: -20 °C to +70 °C



**Relative air humidity**

- Max. 95 %

**Cable length**

- 1.6 m

**Diameter of boom arm**

- 1.1 mm

**Connector**

- 3.5 mm jack plug or 3-Pin connector

**Weight (without cable)**

- Approx. 7 g

**Polar pattern**

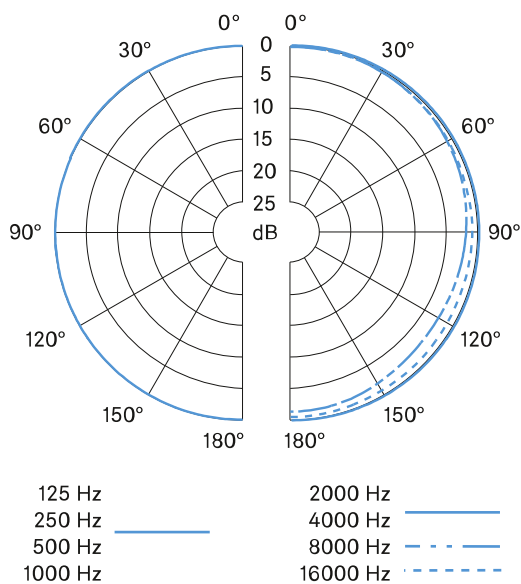

**Frequency response**

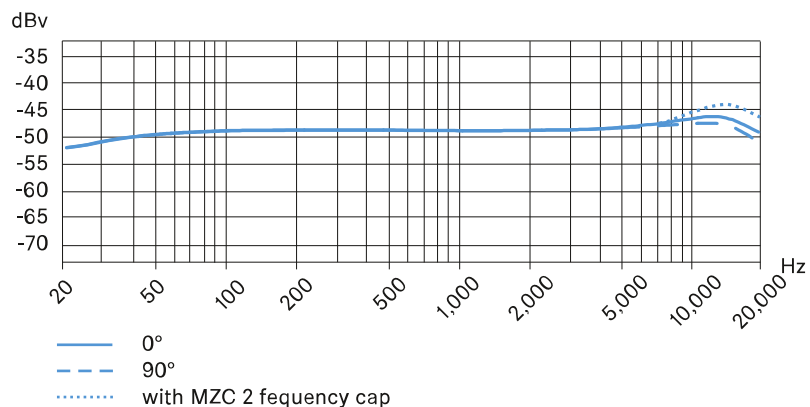

## Headmic 4

### Frequency response

- 20 - 20,000 Hz  $\pm$  2.5 dB

### Pick-up pattern

- Cardioid

### Nominal impedance at 1 kHz

- 1.2 k $\Omega$

### Min. terminating impedance

- 4.7 k $\Omega$

### Sensitivity

- 8 mV/Pa  $\pm$  2.5 dB

### Diameter of mic capsule

- 4.7 mm

### Max. sound pressure level

- 143 dB

### Equivalent noise level

- 30 dB(A)



**Supply current**

- Approx. 240  $\mu$ A

**Power supply**

- 4.5 - 15 V

**Temperature range**

- Operation: -10 °C to +50 °C
- Storage: -20 °C to +70 °C

**Relative air humidity**

- Max. 90 %

**Cable length**

- 1.6 m

**Diameter of boom arm**

- 1.1 mm

**Connector**

- 3.5 mm jack plug or 3-Pin connector

**Weight (without cable)**

- Approx. 7 g

**Polar pattern**

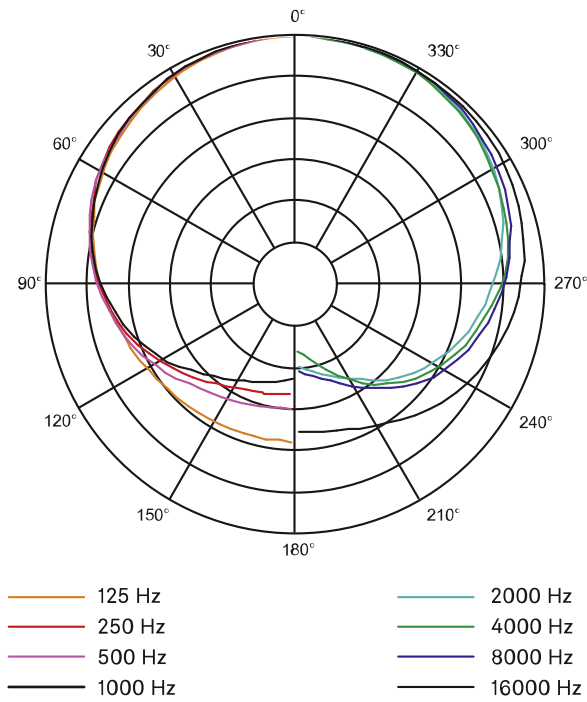

### Frequency response

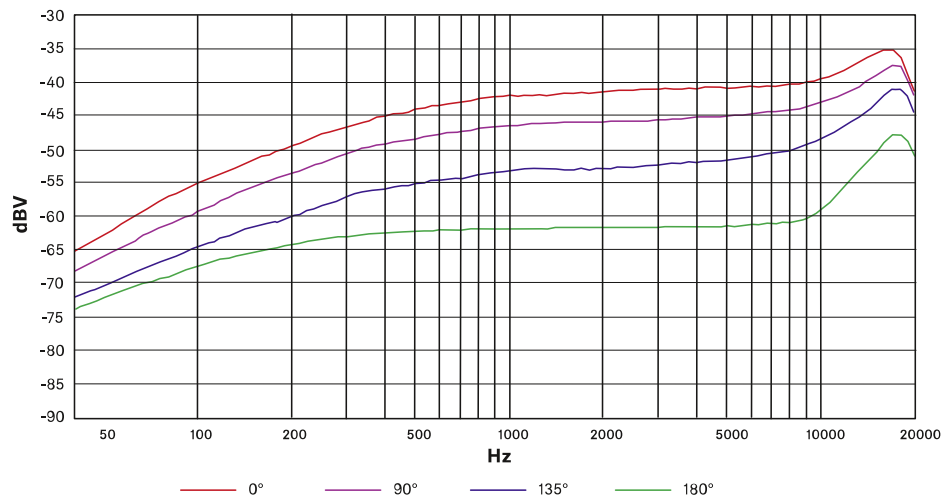

## HS 2

### Frequency response

- 20 - 20,000

### Pick-up pattern

- Omni-directional



**Nominal impedance**

- 1 k $\Omega$

**Min. terminating impedance**

- 4.7 k $\Omega$

**Sensitivity in free field**

- 5 mV/Pa  $\pm$  3 dB

**Diameter of microphone**

- 4.8 mm

**Max. sound pressure level**

- 140 dB

**Equivalent noise level**

- A weighted: 28 dB(A)
- CCIR weighted: 41 dB

**Power supply**

- 7.5 V

**Cable length**

- 1.3 m

**Connector**

- 3.5 mm jack plug or 3-Pin connector

**Weight**

- 3.5 mm jack: approx. 30.1 g
- 3-Pin: 28.9 g

**Frequency response**, Microphone placed in the corner of the mouth, distance to the mouth 3 cm

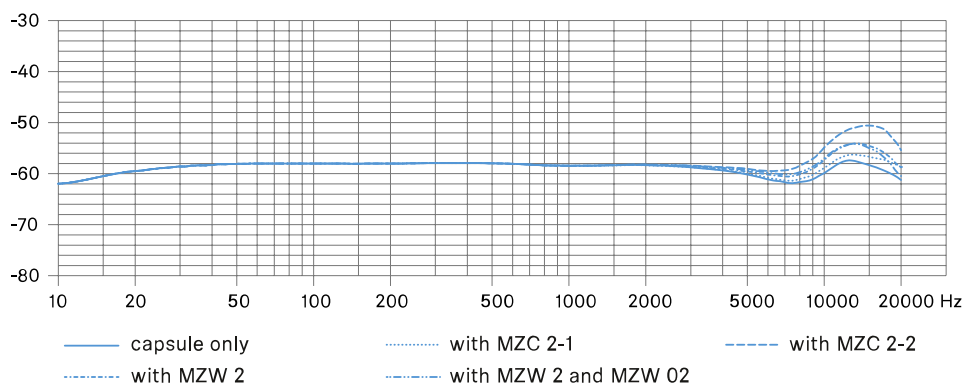

## HSP 2

### Frequency response

- 20 - 20,000 Hz  $\pm$  3 dB

### Pick-up pattern

- Omni-directional

### Nominal impedance at 1 kHz

- 1 k $\Omega$

### Min. terminating impedance

- 4.7 k $\Omega$

### Sensitivity

- 2 mV/Pa  $\pm$  3 dB

### Diameter of mic capsule

- 4.8 mm

### Max. sound pressure level

- 150 dB

### Equivalent noise level

- 28 dB(A)

### Supply current

- Approx. 250  $\mu$ A



**Power supply**

- 4.5 - 15 V

**Temperature range**

- -10 °C to +50 °C

**Relative air humidity**

- Max. 95 %

**Cable length**

- 1.6 m

**Diameter of boom arm**

- 1.1 mm

**Connector**

- 3.5 mm jack plug or 3-Pin connector

**Weight (without cable)**

- Approx. 2.1 g

**Polar pattern**

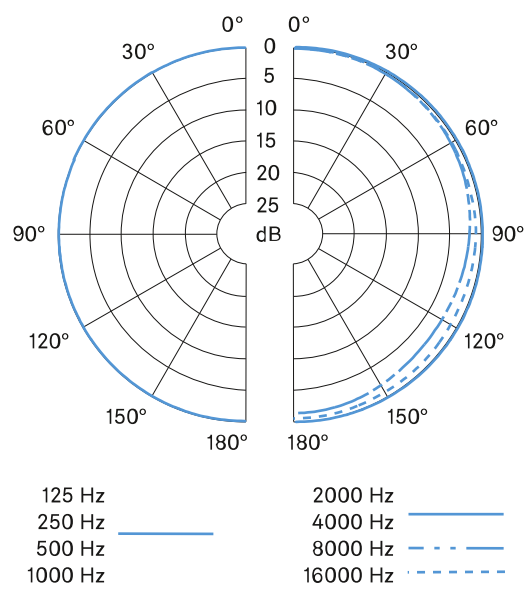

**Frequency response**

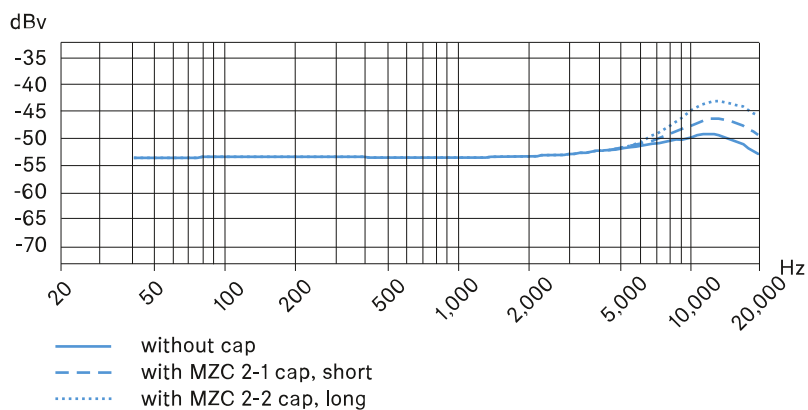

## HSP Essential

### Pick-up pattern

- Omni-directional

### Frequency response

- 20 - 20,000 Hz

### Sensitivity in free field, no load (1 kHz)

- 2.5 mV, Pa  $\pm$  3.5 dB

### Nominal impedance

- 1 k $\Omega$

### Min. terminating impedance

- 4.7 k $\Omega$

### Equivalent noise level

- A weighted: 30 dB
- CCIR weighted: 42 dB

### Max. sound pressure level

- 148 dB

### Connector

- 3.5 mm jack or 3-Pin connector



**Cable length**

- 1.3 m

**Diameter of mic capsule**

- 4.8 mm

**Weight**

- 25 g

**Frequency response capsule only**

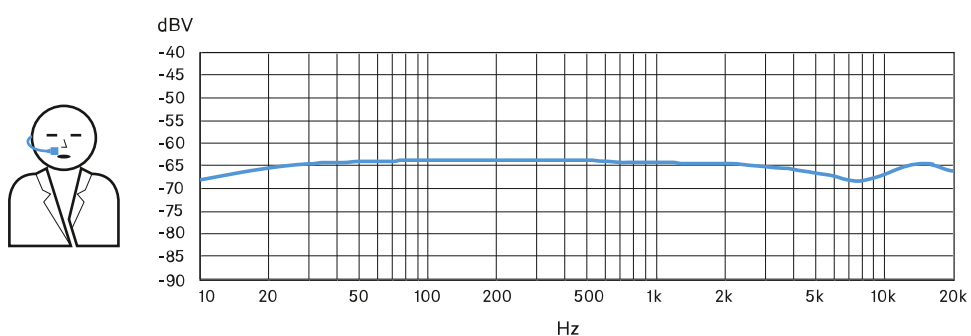

**ME 3**

**Transducer principle**

- pre-polarized condensor microphone

**Pick-up pattern**

- cardioid

**Sensitivity**

- 1.6 mV/Pa

**Sound pressure level**

- 150 dB SPL

**Frequency response**

- 50 - 18,000 Hz

**Connector**

- 3.5 mm jack



### Cable length

- Approx. 1.60 m

### Weight

- Approx. 60 g

### Power supply

- 10 V

### Pin assignment

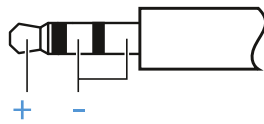

### Polar pattern

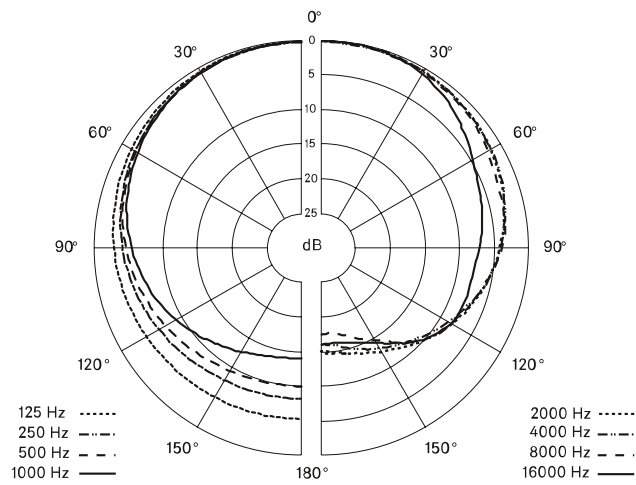

### Frequency response

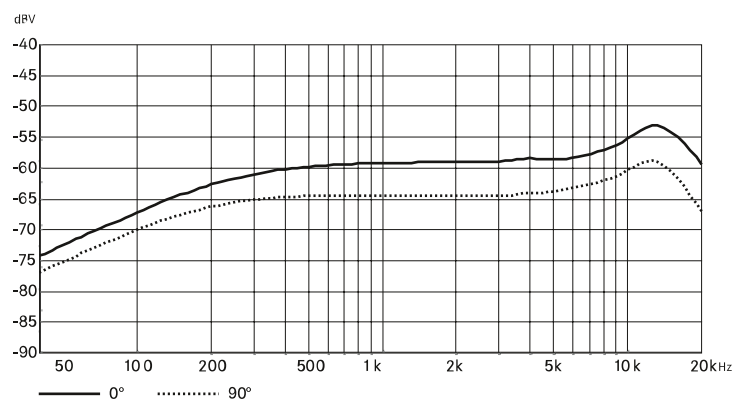



## 5. Regulatory information

Information on manufacturer declarations, environmental and disposal notices, and terms of use.

Model:

- Headmic 1 = Headmic 1 (Black EW), Headmic 1 (Beige EW), Headmic 1 (Silver EW), Headmic 1 (Black 3-Pin), Headmic 1 (Beige 3-Pin), Headmic 1 (Silver 3-Pin)
- Headmic 4 = Headmic 4 (Black EW), Headmic 4 (Beige EW), Headmic 4 (Silver EW), Headmic 4 (Black 3-Pin), Headmic 4 (Beige 3-Pin), Headmic 4 (Silver 3-Pin)
- HS 2 = HS 2 (Beige EW), HS 2 (Black EW), HS 2 (Beige 3-Pin), HS 2 (Black 3-Pin)
- HSP 2 = HSP 2 (Beige EW), HSP 2 (Black EW), HSP 2 (Beige 3-Pin), HSP 2 (Black 3-Pin)
- HSP Essential = HSP Essential (Beige EW), HSP Essential (Black EW), HSP Essential (Beige 3-Pin), HSP Essential (Black 3-Pin)
- ME 3

### Warranty

Sennheiser electronic SE & Co. KG gives a warranty of 24 months on these products.

For the current warranty conditions, please visit our website at [sennheiser.com](https://www.sennheiser.com) or contact your Sennheiser partner.

In the US please contact:

Sennheiser Electronic Corporation

1 Enterprise Drive, Old Lyme, CT 06371

[www.sennheiser.com](https://www.sennheiser.com)

### Warranty for Australia and New Zealand only

Sennheiser Australia Pty Ltd provides a warranty of 24 months on these products. For the current warranty conditions, visit Sennheiser website: Australia: [sennheiser.com](https://www.sennheiser.com), New Zealand: [sennheiser.com](https://www.sennheiser.com)

Sennheiser goods come with guarantees that cannot be excluded under Australian and New Zealand Consumer law. You are entitled to a replacement or refund for a major failure and compensation for any other reasonably foreseeable loss or damage. You are also entitled to have the goods repaired or replaced if the goods fail to be of acceptable quality and the failure does not amount to a major failure.

This warranty is in addition to other rights or remedies under law. Nothing in this warranty excludes, limits or modifies any remedy available to be consumer which is granted by law.

To make a claim under this contract, raise a case via Sennheiser website. Australia: [sennheiser.com/support](https://www.sennheiser.com/support), New Zealand: [sennheiser.com/support](https://www.sennheiser.com/support)



All expenses of claiming the warranty will be borne by the person making the claim.

Sennheiser international warranty is provided by: Sennheiser Australia Pty Ltd (ABN 68 165 388 312) Level 14, Tower A Zenith Building, 821 Pacific Highway, Chatswood NSW 2067, Australia

**Europe**



In compliance with the following requirements

- Regulation (EU) 2023/988 on general product safety
- WEEE Directive (2012/19/EU)



**Italy:**

Headmic 1, Headmic 4, HS 2, HSP 2, ME 3

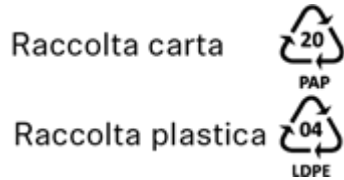

HSP Essential

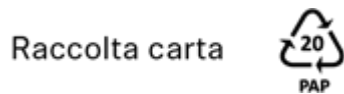

**France:**

Headmic 1, HS 2, HSP 2, ME 3

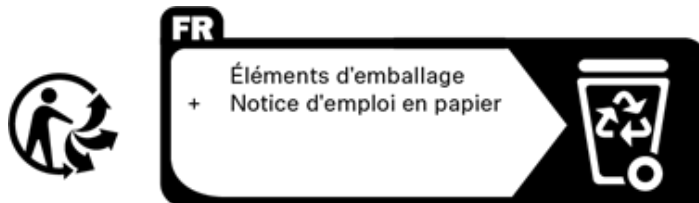

Headmic 4

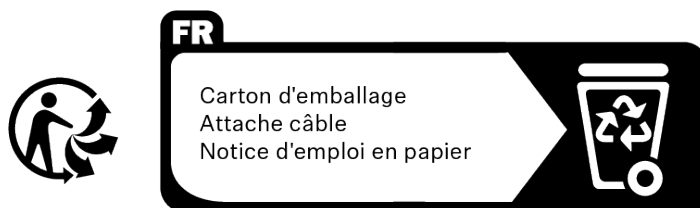

HSP Essential

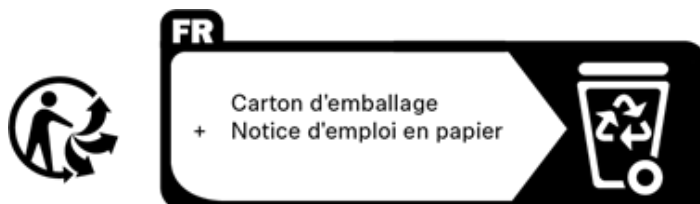

### Notes on disposal

The symbol of the crossed-out dumpster on the product, the (rechargeable) battery (if applicable) and/or the packaging indicates that these products must not be disposed of with normal household waste, but must be disposed of separately at the end of their service life. For the packaging, follow the regulations in your country for separating waste. Improper disposal of packaging materials can be harmful to your health and the environment.

The separate collection of waste electrical and electronic equipment, (rechargeable) batteries (if applicable) and packaging is intended to promote reuse and recycling and to prevent negative impacts on public health and the environment, for example due to hazardous substances contained in these products. At the end of their service life, recycle electrical and electronic equipment and (rechargeable) batteries so that their materials can be reused and to prevent environmental pollution.

If (rechargeable) batteries can be removed without destroying them, you are obliged to dispose of them separately (see the product's operating instructions for information on how to remove the batteries safely). Be especially careful when handling (rechargeable) batteries containing lithium, as these pose special hazards, such as the risk of fire and/or health risks if button cells are swallowed. Reduce battery waste as much as possible by using longer-life batteries or rechargeable batteries.

Further information on the recycling of these products can be obtained from your municipal administration, from the municipal collection points, or from your Sennheiser partner. You may also be able to return electrical or electronic equipment to your distributor, if they are legally required to do so. By disposing of your batteries properly, you are helping to protect public health and the environment.

### EU Declaration of conformity

- RoHS Directive (2011/65/EU)
- EMC Directive (2014/30/EU)

The full text of the EU declaration of conformity is available at the following internet address: [sennheiser.com/download](https://www.sennheiser.com/download).



### United Kingdom



In compliance with the following requirements

- WEEE Regulations (2013)



### UK Declaration of conformity

- RoHS Regulations (2012)
- EMC Regulations (2016)

Importer: Sennheiser UK Ltd.

Pacific House, Third Avenue, Globe Park, Marlow

Buckinghamshire SL7 1EY, United Kingdom

### Australia / New Zealand

Headmic 1, Headmic 4



### China

Headmic 1, HS 2, ME 3

#### China RoHS

部件名称 (Parts)	有害物质										产品环保年限 EFUP
	铅 (Pb)	汞 (Hg)	镉 (Cd)	六价铬 (Cr6+)	多溴联苯 (PBB)	多溴二苯醚 (PBDE)	邻苯二甲酸二 (2-乙基己)酯 (DEHP)	邻苯二甲 酸丁苄酯 (BBP)	邻苯二甲 酸二丁酯 (DBP)	邻苯二甲 酸二异丁酯 (DIBP)	
金属部件 (Metal parts)	x	o	o	o	o	o	o	o	o	o	15
电缆及电缆组件 (Cables & Cable Assemblies)	x	o	o	o	o	o	o	o	o	o	15

本表格依据 SJ/T 11364 的规定编制。

o: 表示该有害物质在该部件所有均质材料中的含量均在 GB/T 26572 规定的限量要求以下。

x: 表示该有害物质至少在该部件的某一均质材料中的含量超出 GB/T 26572 规定的限量要求。

Headmic 4



**China RoHS**

部件名称 (Parts)	有害物质										
	铅 (Pb)	汞 (Hg)	镉 (Cd)	六价铬 (Cr6+)	多溴联苯 (PBB)	多溴二苯醚 (PBDE)	邻苯二甲酸二 (2-乙基己)酯 (DEHP)	邻苯二甲 酸丁苯酯 (BBP)	邻苯二甲 酸二丁酯 (DBP)	邻苯二甲 酸二异丁酯 (DIBP)	产品环保年限 EFUP
金属部件 (Metal parts)	x	o	o	o	o	o	o	o	o	o	15
电路模块 (Circuit Modules)	x	o	o	o	o	o	o	o	o	o	15

本表格依据 SJ/T 11364 的规定编制。  
 o: 表示该有害物质在该部件所有均质材料中的含量均在 GB/T 26572 规定的限量要求以下。  
 x: 表示该有害物质至少在该部件的某一均质材料中的含量超出 GB/T 26572 规定的限量要求。

HSP 2, HSP Essential:

**China RoHS**

部件名称 (Parts)	有害物质										
	铅 (Pb)	汞 (Hg)	镉 (Cd)	六价铬 (Cr6+)	多溴联苯 (PBB)	多溴二苯醚 (PBDE)	邻苯二甲酸二 (2-乙基己)酯 (DEHP)	邻苯二甲 酸丁苯酯 (BBP)	邻苯二甲 酸二丁酯 (DBP)	邻苯二甲 酸二异丁酯 (DIBP)	产品环保年限 EFUP
金属部件 (Metal parts)	x	o	o	o	o	o	o	o	o	o	15
电路模块 (Circuit Modules)	x	o	o	o	o	o	o	o	o	o	15
电缆及电缆组件 (Cables & Cable Assemblies)	x	o	o	o	o	o	o	o	o	o	15

本表格依据 SJ/T 11364 的规定编制。  
 o: 表示该有害物质在该部件所有均质材料中的含量均在 GB/T 26572 规定的限量要求以下。  
 x: 表示该有害物质至少在该部件的某一均质材料中的含量超出 GB/T 26572 规定的限量要求。

**Vietnam**

Kể từ ngày 1 tháng 12 năm 2012, các sản phẩm được sản xuất bởi Sennheiser tuân thủ Thông tư 30/2011/TT-BCT quy định về giới hạn cho phép đối với một số chất độc hại trong các sản phẩm điện và điện tử.

