



ew IEM G4

EK IEM G4, SR IEM G4

PDF export of the original HTML manual



Contents

1. Preface.....	4
2. Product information.....	5
Products of the ew IEM G4 series.....	5
EK IEM G4 stereo diversity receiver.....	5
SR IEM G4 stereo transmitter.....	7
AC 41 antenna combiner.....	8
Accessories.....	9
Earphones.....	9
Rechargeable battery and charger.....	13
Antennas and accessories.....	14
Accessories for rack mounting.....	15
The frequency bank system.....	16
Frequency tables.....	17
3. Instruction manual.....	18
EK IEM G4 diversity receiver.....	18
Product overview.....	18
Inserting and removing the batteries/rechargeable batteries.....	20
Connecting earphones to the EK IEM G4.....	21
Attaching the diversity receiver to your clothing.....	22
Switching the EK IEM G4 on and off.....	23
Lock-off function.....	24
Displays on the EK IEM G4 display panel.....	26
Home Screen.....	27
Battery status.....	30
Buttons for navigating through the menu.....	31
Menu structure.....	33
Setting options in the menu.....	34
SR IEM G4 stereo transmitter.....	59
Product overview.....	59
Connecting/disconnecting the SR IEM G4 with/from the power supply.....	61
Creating a data network.....	62
Connecting audio signals.....	63
Daisy chaining audio signals.....	65
Connecting antennas.....	66
Installing the SR IEM G4 in a rack.....	67



Switching the SR IEM G4 on and off.....	71
Using the headphone output.....	72
Configuring the audio channels (mono/stereo).....	73
Deactivating the RF signal (RF mute).....	74
Lock-off function.....	76
Displays on the SR IEM G4 display panel.....	77
Buttons for navigating the SR IEM G4 menu.....	79
Menu structure.....	80
Setting options in the menu.....	81
AC 41 antenna combiner.....	97
Product overview.....	97
Connecting/disconnecting the AC 41 to/from the power supply system.....	99
Connecting the AC 41 with transmitters.....	100
Connecting antennas.....	102
Installing the AC 41 in a rack.....	103
Switching the AC 41 on and off.....	106
Meaning of the LEDs.....	107
Establishing a radio link.....	108
Synchronizing devices.....	109
Cleaning and maintenance.....	113
4. Specifications.....	114
EK IEM G4.....	114
SR IEM G4.....	116
AC 41.....	118
IE 100 PRO earphones.....	119
IE 500 PRO earphones.....	120
IE 400 PRO earphones.....	121
IE 4 earphones.....	122
Pin assignment.....	123
5. Regulatory information.....	125



1. Preface

PDF Export of the Original HTML Manual

This PDF document is an automatic export of an interactive set of HTML manuals. Some content and interactive elements may not be included in the PDF because they cannot be displayed in this format. In addition, automatically generated page breaks may cause related content to be slightly shifted. We can therefore only guarantee the completeness of the information in the HTML manual and recommend using it. You can find it in the Documentation Portal at www.sennheiser.com/documentation.



2. Product information

All information about the product and available accessories at a glance.

Products of the ew IEM G4 series

EK IEM G4 stereo diversity receiver



The EK IEM G4 stereo receiver is available in the following versions:

EK IEM G4-A1	470 - 516 MHz	Art. no. 509621
EK IEM G4-A	516 - 558 MHz	Art. no. 509622
EK IEM G4-AS	520 - 558 MHz	Art. no. 509634
EK IEM G4-GB	606 - 648 MHz	Art. no. 509911
EK IEM G4-G	566 - 608 MHz	Art. no. 509623
EK IEM G4-B	626 - 668 MHz	Art. no. 509624
EK IEM G4-C	734 - 776 MHz	Art. no. 509625
EK IEM G4-C-TH	748.2 - 757.8 MHz	Art. no. 509918



EK IEM G4-D	780 - 822 MHz	Art. no. 509635
EK IEM G4-E	823 - 865 MHz	Art. no. 509912

i You can find more detailed information about the EK IEM G4 in the following sections:

- **Startup and operation:** [EK IEM G4 diversity receiver](#)
- **Specifications:** [EK IEM G4](#)



SR IEM G4 stereo transmitter



The SR IEM G4 stereo transmitter is available in the following versions:

EK IEM G4-A1	470 - 516 MHz	Art. no. 509617
EK IEM G4-A	516 - 558 MHz	Art. no. 509618
SR IEM G4-A30	516 - 558 MHz	Art. no. 509914
EK IEM G4-AS	520 - 558 MHz	Art. no. 509631
EK IEM G4-GB	606 - 648 MHz	Art. no. 509910
EK IEM G4-G	566 - 608 MHz	Art. no. 509619
EK IEM G4-B	626 - 668 MHz	Art. no. 509620
SR IEM G4-B30	626 - 668 MHz	Art. no. 509916
EK IEM G4-C	734 - 776 MHz	Art. no. 509632
EK IEM G4-D	780 - 822 MHz	Art. no. 509633
EK IEM G4-E	823 - 865 MHz	Art. no. 509921

i You can find more detailed information about the SR IEM G4 in the following sections:

- **Startup and operation:** [SR IEM G4 stereo transmitter](#)
- **Specifications:** [SR IEM G4](#)



AC 41 antenna combiner



The AC 41 antenna combiner is available in the following versions:

AC 41-EU	Art. no. 576761	NT 3-1-EU
AC 41-US	Art. no. 576762	NT 3-1-US
AC 41-UK	Art. no. 576761	NT 3-1-UK

i You can find more detailed information about the AC 41 in the following sections:

- **Startup and operation:** [AC 41 antenna combiner](#)
- **Specifications:** [AC 41](#)



Accessories

A variety of accessories are available for the ew IEM G4 series.

Earphones

IE 100 PRO

IE 100 PRO BLACK | Art. no. 508940



IE 100 PRO CLEAR | Art. no. 508941



IE 100 PRO RED | Art. no. 508942



i Specifications: [IE 100 PRO earphones](#)

IE 400 PRO

IE 400 PRO SMOKY BLACK | Article no. 507483



IE 400 PRO CLEAR | Article no. 507484



i Specifications: [IE 400 PRO earphones](#)

IE 500 PRO

IE 500 PRO SMOKY BLACK | Article no. 507479



IE 500 PRO CLEAR | Article no. 507480



i Specifications: [IE 500 PRO earphones](#)

IE 4

IE 4 | Article no. 500432



i Specifications: [IE 4 earphones](#)



Rechargeable battery and charger

BA 2015 rechargeable battery

The BA 2015 rechargeable battery is designed for use with 2000 IEM series handheld transmitters, bodypack transmitters and bodypack receivers.

Art. no. 009950



L 2015 charger

The BA 2015 rechargeable battery can be charged in the L 2015 charger on its own or inside of the bodypack transmitter/bodypack receiver.

Art. no. 009828





Antennas and accessories

Omni-directional antennas

A 1031-U | passive omni-directional antenna | Art. no. 004645

Directional antennas

A 2003 UHF | passive directional antenna | Art. no. 003658

Antenna cable

GZL 1019, BNC/BNC coaxial cable, antenna cable with 50 Ω characteristic (wave) impedance

- **GZL 1019-A1** | 1 m | Art. no. 002324
- **GZL 1019-A5** | 5 m | Art. no. 002325
- **GZL 1019-A10** | 10 m | Art. no. 002326



Accessories for rack mounting

Rack mount kit

GA 3 rack mount kit | Art. no. 503167

19" rack adapter for mounting the EM 100 G4, EM 300 G4, EM 500 G4 or SR IEM G4 in a 19" rack.



Antenna front mounting kit

Antennen-Frontmontageset AM 2 | Art. no. 009912

Antenna front mounting kit for installing antenna connections on the front of the rack when using the EM 100 G4, EM 300 G4, EM 500 G4 or SR IEM G4 together with the GA 3 rack mounting kit.





The frequency bank system

There are different frequency ranges in the UHF band available for transmission.

The following frequency ranges are available for the ew IEM G4 series:

- **A1** range: 470 - 516 MHz
- **A** range: 516 - 558 MHz
- **AS** range: 520 - 558 MHz
- **G** range: 566 - 608 MHz
- **GB** range: 606 - 648 MHz
- **B** range: 626 - 668 MHz
- **C** range: 734 - 776 MHz
- **C-TH** range: 748.2 - 757.8 MHz
- **D** range: 780 - 822 MHz
- **E** range: 823 - 865 MHz

Every frequency range has 26 frequency banks with up to 16 channels:

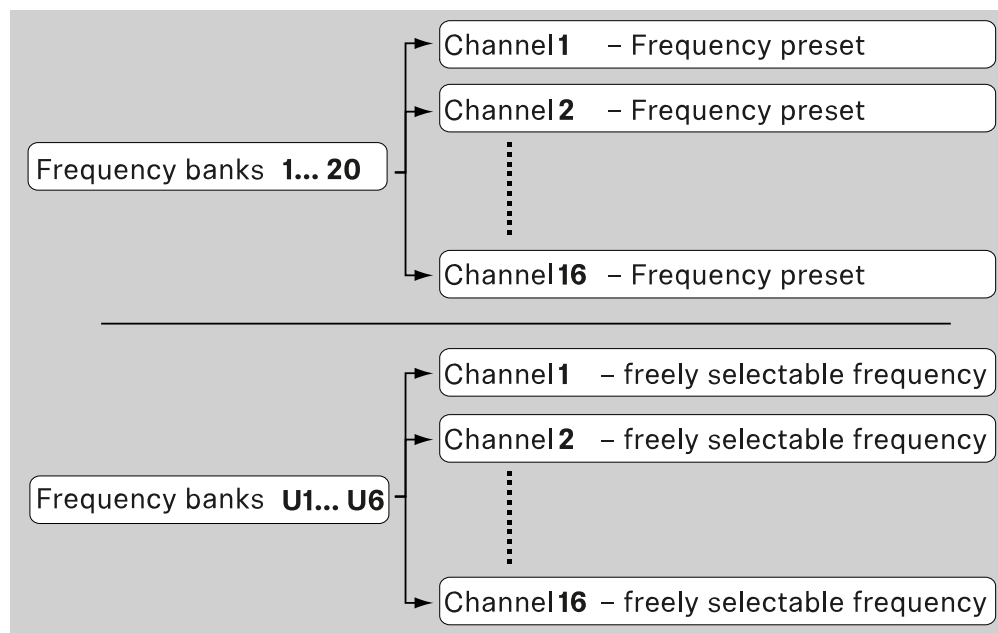

i You can find information about the frequency presets in the frequency tables of the respective frequency ranges under [Frequency tables](#).



Frequency tables

You can find frequency tables for all available frequency ranges in the download section of the Sennheiser website under: [sennheiser.com/download](https://www.sennheiser.com/download).

Enter **ew G4** into the search bar to show the frequency tables.



3. Instruction manual

Starting up and operating devices of the ew IEM G4 series.

EK IEM G4 diversity receiver

Product overview

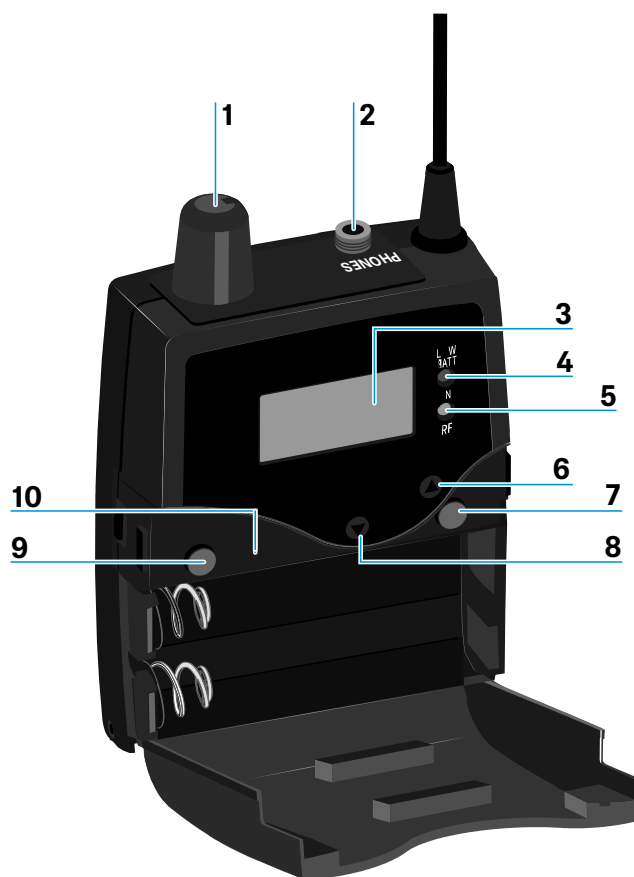

1 Volume control with on/off switch
see [Connecting earphones to the EK IEM G4](#)

see [Switching the EK IEM G4 on and off](#)

2 3.5 mm **PHONES** jack socket, lockable
Jack for connecting an earphone

see [Connecting earphones to the EK IEM G4](#)

3 Display

see [Displays on the EK IEM G4 display panel](#)



4 Operation and battery indicator, red LED

see [Switching the EK IEM G4 on and off](#)

see [Battery status](#)

5 Wireless reception indicator, green LED

illuminated = RF

see [Squelch menu item](#)

6 UP button

see [Buttons for navigating through the menu](#)

7 SET button

see [Buttons for navigating through the menu](#)

8 DOWN button

see [Buttons for navigating through the menu](#)

9 ESC button

see [Buttons for navigating through the menu](#)

10 Infra-red interface

see [Synchronizing devices](#)



Inserting and removing the batteries/rechargeable batteries

You can operate the diversity receiver either with batteries (AA, 1.5 V) or with the rechargeable Sennheiser BA 2015 battery.

- ▶ Press the two catches and open the battery compartment cover.
- ▶ Insert the batteries or the rechargeable battery as shown below.
- ▶ Please observe correct polarity when inserting the batteries.



- ▶ Close the battery compartment.
 - ✓ The cover locks into place with an audible click.



Connecting earphones to the EK IEM G4

WARNING



Danger due to high volume levels

Volume levels that are too high may damage your hearing.

- ▶ Turn down the volume of the headphone output before you put on the headphone.

To connect the earphones to the receiver:

- ▶ Insert the cable's 3.5 mm jack plug into the **PHONES** socket on the receiver as shown in the diagram.



- i** The ground connection of the earphone cable acts as an antenna for the second diversity branch. For details on the pin assignment, see [Pin assignment](#).



Attaching the diversity receiver to your clothing

You can use the belt clip to attach the diversity receiver to your waistband or on a guitar strap.

The belt clip is detachable so that you can also attach the diversity receiver with the antenna pointing downwards. To do so, withdraw the belt clip from its fixing points and attach it the other way round.

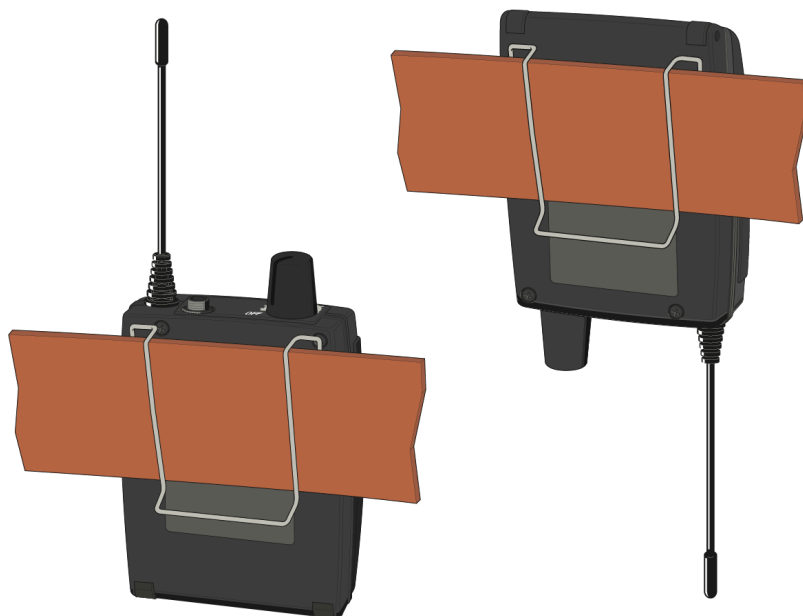

The belt clip is secured so that it cannot slide out of its fixing points accidentally.

To detach the belt clip:

- ▶ Lift the belt clip as shown in the diagram.
- ▶ Press one side of the clip downward on the fixing hole and pull it out of the housing.
- ▶ Do the same thing on the other side.

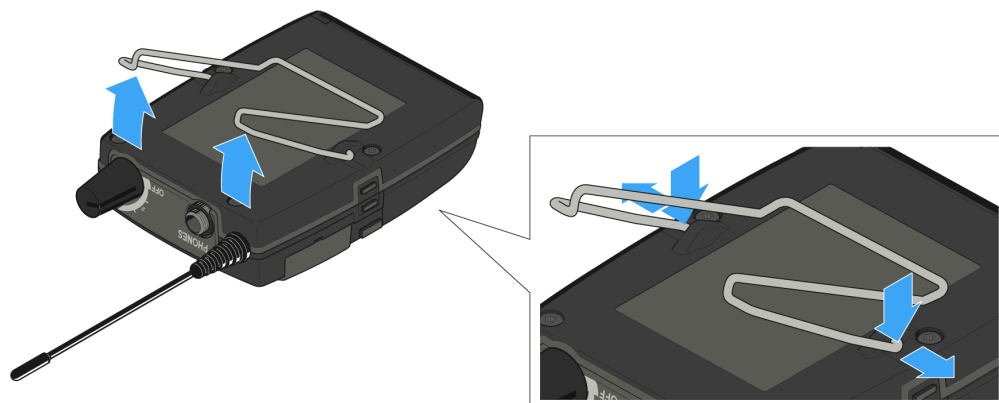



Switching the EK IEM G4 on and off

To switch the receiver on:

- ▶ Turn the volume control clockwise until it clicks.



- ✓ The red **ON** LED is illuminated and the Frequency/Name standard display appears.

To switch the receiver off:

- ▶ Turn the volume control counterclockwise until it clicks.
- ✓ The red **ON** LED will go out.



Lock-off function

You can set the automatic lock-off function in the Auto Lock menu (see [Auto Lock menu item](#)).

When you have switched on the lock-off function, you will have to turn the receiver off and on again in order to operate it.

To temporarily deactivate the lock-off function:

- ▶ Press the **SET** button.
 - ✓ Locked appears in the display panel.
- ▶ Press the **UP** or **DOWN** button.
 - ✓ Unlock? appears in the display panel.
- ▶ Press the **SET** button.

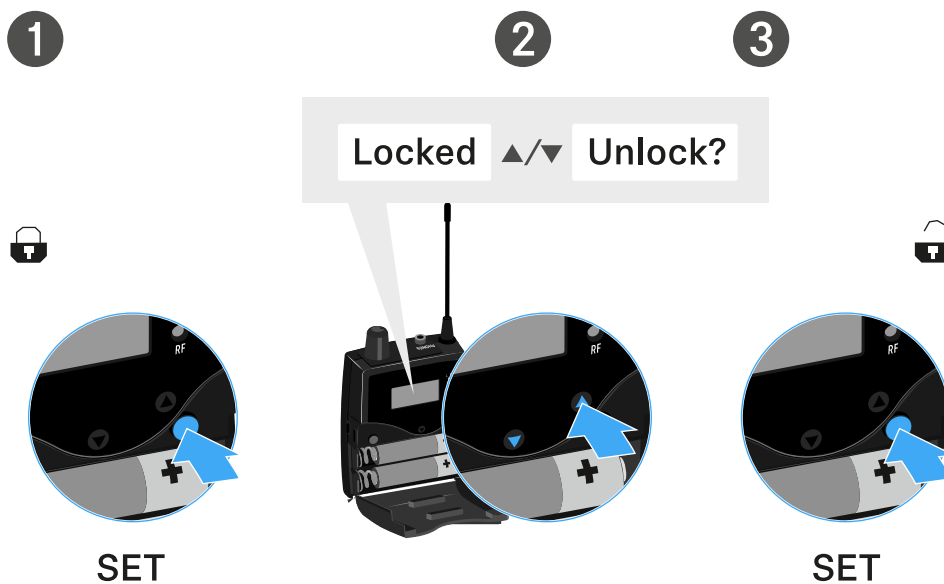

- ✓ Lock-off function is now temporarily deactivated.

When you are in the operating menu

- Lock-off function is deactivated long enough for you to work in the operating menu.

When one of the standard displays is shown

- Lock-off function is automatically activated after 10 seconds.



The lock-off function icon flashes while the lock-off function is activated again.



Displays on the EK IEM G4 display panel

Status information such as reception quality, battery status, audio level, etc. is displayed on the home screen of the display panel.

The display panel also displays the operating menu which you can use to configure all of the settings.



Home Screen

After you switch on the receiver, the display panel initially displays the Sennheiser logo. After a short time, the home screen is then displayed.

The home screen has three different standard displays.

- On the home screen, press the **ESC** button to switch between the standard displays.
- In Stereo mode, you can also press the **UP/DOWN** button to switch between the standard displays.

Frequency/Name standard display

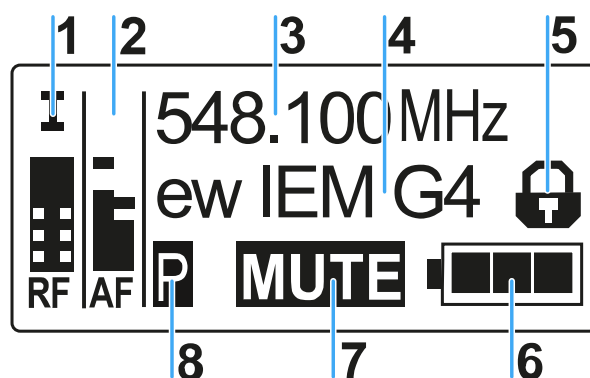

1 RF level (radio frequency)

RF signal level display

including the display of the squelch threshold (see [Squelch menu item](#))

2 AF audio level (audio frequency)

Displays the audio level of the received transmitter (separated by channel in Stereo mode).

When the display shows full deflection, the audio input level is excessively high.

see [Balance menu item](#)

3 Frequency

Current receiving frequency

see [Frequency Preset menu item](#)

4 Name

Freely selectable name of the receiver

see [Name menu item](#)



5 Lock-off function

Lock-off function is activated.

see [Lock-off function](#)

6 Battery status

see [Battery status](#)

7 MUTE muting function

The transmitter's RF signal is deactivated, see [Mode menu item](#)

or the transmitter is in Mono mode, see [Mode menu item](#)

8 pilot tone P

P = Activated pilot tone evaluation

No symbol = Evaluation is deactivated

P is black = Pilot tone is being received on the current frequency

see [Advanced -> Limiter menu item](#)

Bank/Frequency/Limiter standard display

The Bank/Frequency/Limiter standard display also shows the audio channel (Stereo/Focus) and the limiter.

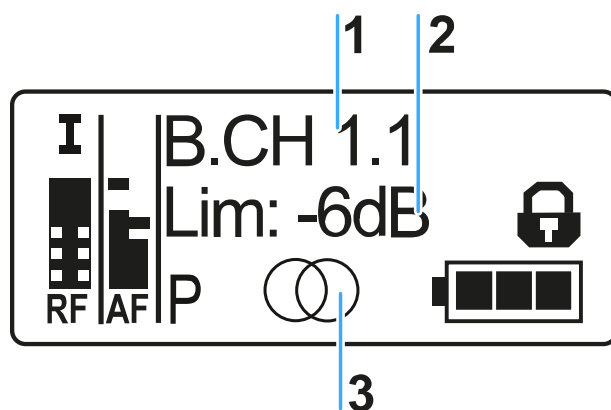

1 Frequency bank and channel

see [Frequency Preset menu item](#)

2 Limiter

see [Advanced -> Limiter menu item](#)



3 Audio channel, stereo

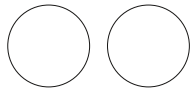

Focus:

see [Mode menu item](#)

Frequency/High Boost standard display

The Frequency/High Boost standard display also shows the audio channel (Stereo/Focus) and the treble boost.

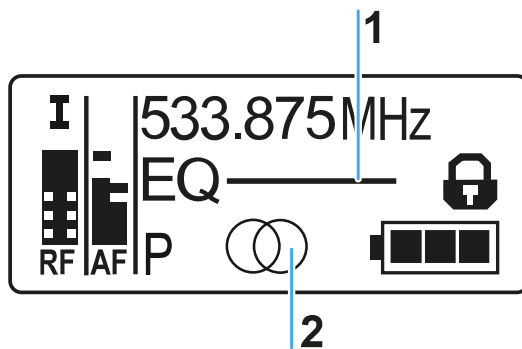

1 Treble boost EQ

see [High Boost menu item](#)

2 Audio channel, stereo

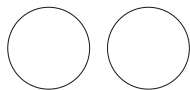

Focus:

see [Mode menu item](#)



Battery status

Charge status of the batteries:

	100 %	> 8 h
	70 %	4 - 6 h
	30 %	2 - 3 h
LOW BATT		

Charge status is critical (LOW BATT):

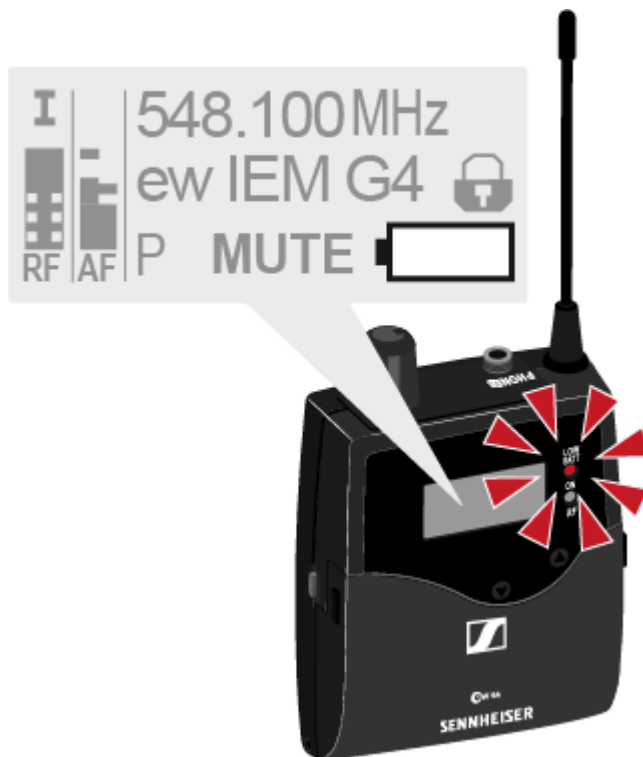



Buttons for navigating through the menu

To navigate through the EK IEM G4 operating menu, you need the following buttons.

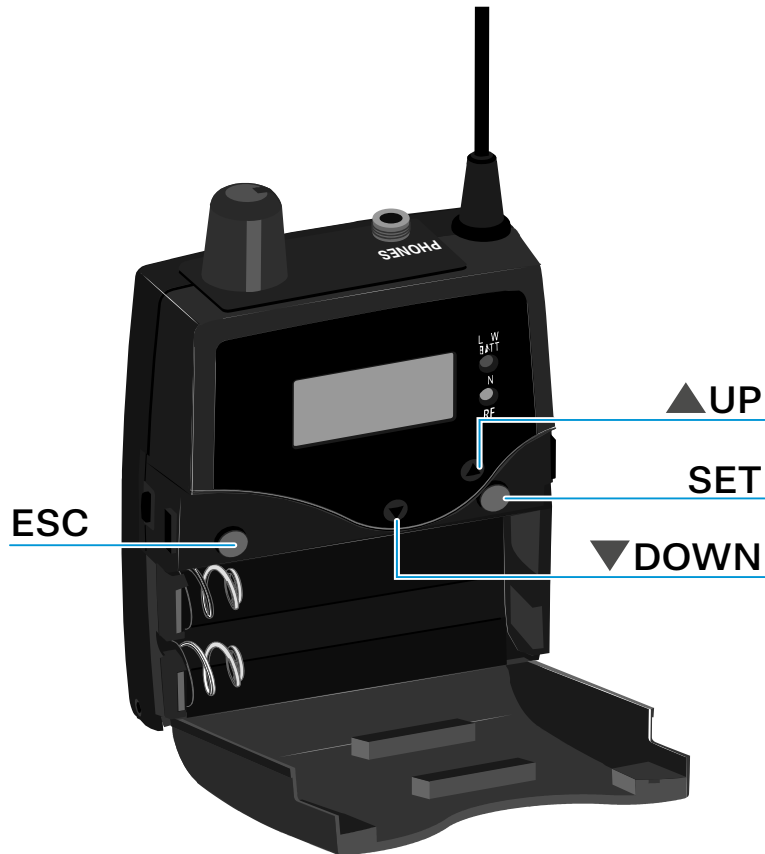

ESC



Press the **ESC** button

- Cancels the entry and returns to the current standard display
- Selects a standard display (see [Home Screen](#))

SET



Press the **SET** button

- Changes from the current standard display to the operating menu
- Calls up a menu item
- Changes to a submenu
- Stores the settings and returns to the operating menu



Press the **UP** or **DOWN** button

- Changes to the previous or next menu item
- Changes the setting of a menu item
- In Focus mode: Adjusts the balance
- In Stereo mode: Selects a standard display (see [Home Screen](#))



Menu structure

The figure shows the complete EK IEM G4 menu structure in an overview.

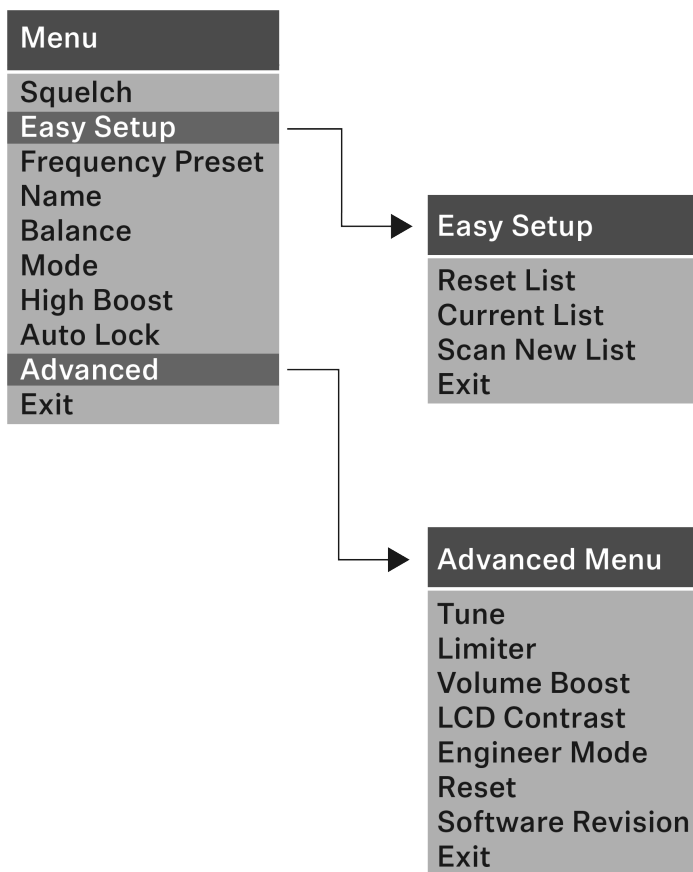



Setting options in the menu

In the EK IEM G4 menu, you can configure the following settings.

Adjusting the squelch threshold

- See [Squelch menu item](#)

Scanning for unused frequency presets, releases and selects frequency presets

- See [Easy Setup menu item](#)

Setting the frequency bank and the channel

- See [Frequency Preset menu item](#)

Entering a freely selectable name

- See [Name menu item](#)

Adjusting the balance

- See [Balance menu item](#)

Adjusting Stereo or Focus mode

- See [Mode menu item](#)

Activating/deactivating the treble boost

- See [High Boost menu item](#)

Activating/deactivating automatic the lock-off function

- See [Auto Lock menu item](#)

Configuring enhanced settings in the Advanced Menu:

- Setting the receiving frequencies for the frequency banks U1 to U6
- Adjusting the limiter
- Adjusting the volume boost
- Adjusting the contrast of the display panel
- Adjusting the menu item and loading profiles
- Resetting the settings made in the operating menu
- Displaying the current software revision
- See [Advanced menu item](#)

Squelch menu item

You can adjust the squelch threshold in the Squelch menu item.



Setting range:

- 5 to 25 dB μ V, adjustable in 2 dB steps

The squelch threshold is displayed on the home screen in the RF signal level area.

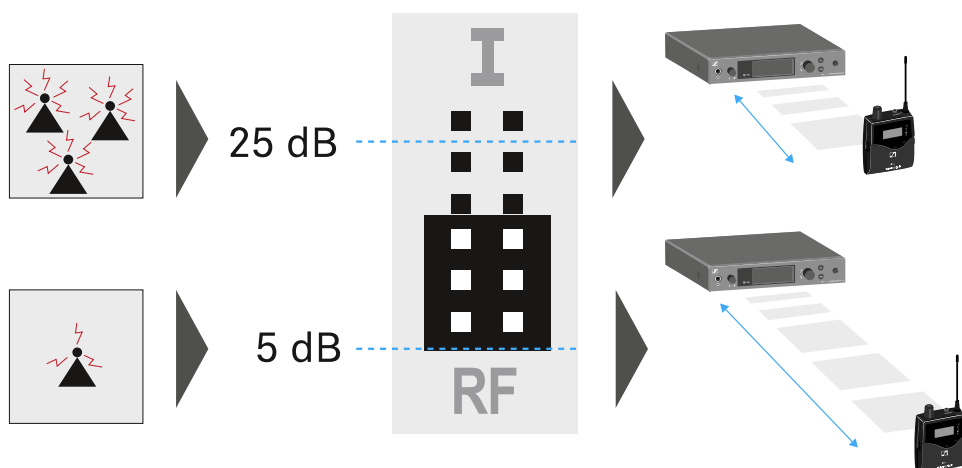

WARNING



Risk of hearing and material damage

If you set the squelch threshold to a very low value, a very loud hissing noise can occur in the receiver. This hissing noise can be loud enough to cause hearing damage or overload your system's loudspeakers.

- ▶ Before adjusting the squelch threshold, set the volume of the audio output to the minimum.
- ▶ Never change the squelch threshold during a live transmission.

To open the Squelch menu item:

- ▶ On the home screen, press the **SET** button to open the operating menu.
- ▶ Press the **UP** or **DOWN** button until the Squelch menu item appears in the selection frame.
- ▶ Press the **SET** button to open the menu item.
- ▶ Adjust the settings as desired.

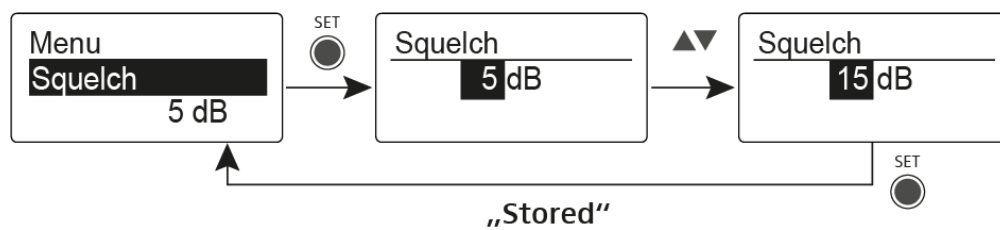

- ▶ Press the **SET** button to save the changes you made to the settings. **OR**
- ▶ Press the **ESC** button to cancel the entry without saving the setting.



Easy Setup menu item

You can scan for unused frequencies using the Easy Setup menu item.

i Switch off all transmitters before you perform the scan. If transmitters are still switched on, they are detected as unavailable frequencies and the frequencies that are actually available cannot then be used.

i The squelch threshold setting influences the result. Set the squelch threshold to a low level for as many frequencies as possible, and to a high level for as many safe frequencies as possible ([Squelch menu item](#)).

To open the Easy Setup menu item:

- ▶ On the home screen, press the **SET** button to open the operating menu.
- ▶ Press the **UP** or **DOWN** button until the Easy Setup menu item appears in the selection frame.
- ▶ Press the **SET** button to open the menu item.
- ▶ Adjust the settings as desired.

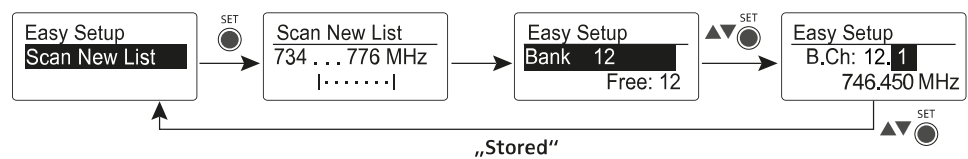

Scan New List

- ▶ Select Scan New List to scan for unused frequencies.
- ▶ Press the **SET** button to start the scan.
 - ✓ The frequency range of the receiver is scanned. As a result, the number of unused frequencies is displayed for every frequency bank.
- ▶ Press the **UP** or **DOWN** buttons to select a frequency bank.
- ▶ Press the **SET** button to confirm your selection.
- ▶ Press the **UP** or **DOWN** buttons to select an unused frequency from the selected bank.



- ▶ Press the **SET** button to save the changes you made to the settings. **OR**
- ▶ Press the **ESC** button to cancel the entry without saving the setting.

Current List

- ▶ Select Current List to show the list of unused frequencies from the last scan.

Reset

- ▶ Select Reset List to delete the list of unused frequencies.

Performing multi-channel frequency setup

i As an alternative to the following procedure, multi-channel frequency setup can also be performed using the Sennheiser Wireless Systems Manager (WSM) software. For more information about controlling devices via the Sennheiser Wireless Systems Manager software, refer to the instruction manual for the software. You can download the software here: sennheiser.com/wsm.

- ▶ To perform the automatic frequency setup for multiple radio links simultaneously: Connect all of the SR IEM G4 transmitters to one network using a network switch. See [Creating a data network](#).
 - ✓ The automatic frequency setup function only works for transmitters in the same frequency range. Transmitters in a different frequency range are not included.
- ▶ Please note that all transmitters must be in the same IP address range.
 - The IP addresses can be automatically assigned if there is a DHCP server in the network.
 - If there is no DHCP server in the network, the IP addresses must be assigned manually. See [Advanced > IP Address menu item](#).
 - Assign the IP addresses for all transmitters in the 192.168.x.x range (the link-local range 169.254.x.x is also a possible alternative).
- ▶ Open the Easy Setup menu item on one of the transmitters.
 - ✓ The Mute RF For Connected Devices? message appears.



- ▶ Press the **jog dial** to confirm the message and deactivate the radio signal for all connected transmitters.
 - ✓ All connected transmitters in the same frequency range will switch to Easy Setup Sync mode.



- ▶ Perform a frequency scan on an EK IEM G4 portable receiver as described above.



- ▶ From the scan results on the receiver, select a frequency bank with enough free channels.
- ▶ Hold the infrared interface of the EK IEM G4 receiver in front of the infrared interface of an SR IEM G4 transmitter to transfer the scan results from the receiver to this transmitter.

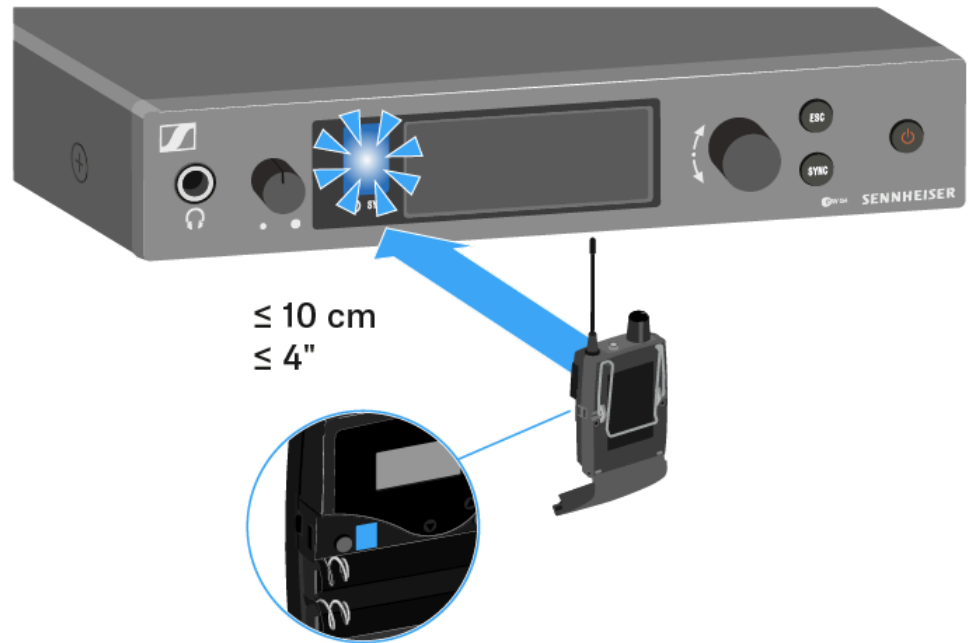

- ✓ The selected transmitter becomes the master transmitter.

The display panels of the other transmitters will display the message Assign New Frequency?.

Receivers with non-compatible frequency ranges will not display a message.



- ▶ Select an unused frequency for one of the connected transmitters on the master transmitter.
- ✓ The frequency selected on the master transmitter will also be shown on the display panel of the connected transmitters.

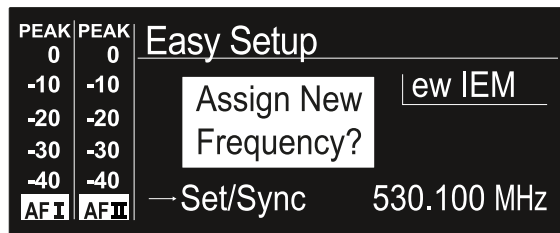

- ▶ Press the **jog dial** (SET) on the particular transmitter to save your selected frequency and synchronize it with the corresponding receiver at a later point (see [Synchronizing devices](#)). **OR**
- ▶ Press the SYNC button to synchronize the selected frequency with the receiver immediately.
- ▶ Use this procedure to assign an unused frequency to all connected transmitters, one after another.
- ▶ For the last step, assign a frequency to the master transmitter.
 - ✓ This completes the multi-channel frequency setup.



Frequency Preset menu item

In the Frequency Preset menu item, you can adjust the receiving frequency of the receiver by adjusting the frequency bank and the channel.

i To open the Frequency Preset menu item: [Advanced](#) -> [Tune menu item](#).

Um den Menüpunkt Frequency Preset zu öffnen:

- ▶ On the home screen, press the **SET** button to open the operating menu.
- ▶ Press the **UP** or **DOWN** button until the Frequency Preset menu item appears in the selection frame.
- ▶ Press the **SET** button to open the menu item.
- ▶ Adjust the settings as desired.

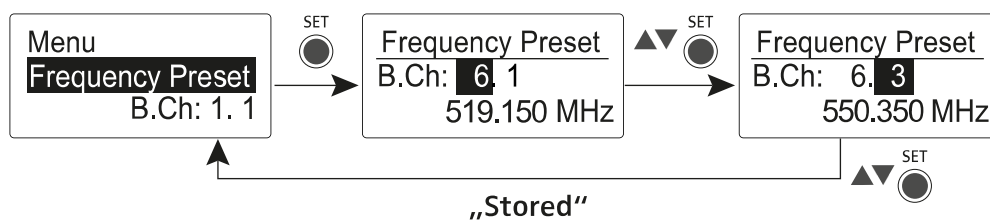

- ▶ Press the **SET** button to save the changes you made to the settings. **OR**
- ▶ Press the **ESC** button to cancel the entry without saving the setting.



Name menu item

In the Name menu item you can enter a name for the radio link.

To open the Name menu item:

- ▶ On the home screen, press the **SET** button to open the operating menu.
- ▶ Press the **UP** or **DOWN** button until the Squelch menu item appears in the selection frame.
- ▶ Press the **SET** button to open the menu item.
- ▶ Adjust the settings as desired.

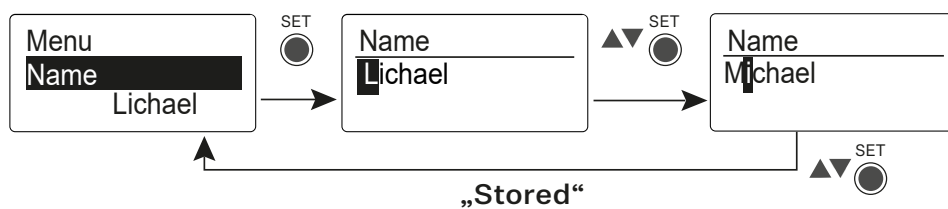

- ▶ Press the **SET** button to save the changes you made to the settings. **OR**
- ▶ Press the **ESC** button to cancel the entry without saving the setting.



Balance menu item

In the Balance menu item you can adjust the balance of the audio channels.

Setting range: 31 steps: L = R, L1 to L15 and R1 to R15

To open the Balance menu item:

- ▶ On the home screen, press the **SET** button to open the operating menu.
- ▶ Press the **UP** or **DOWN** button until the Balance menu item appears in the selection frame.
- ▶ Press the **SET** button to open the menu item.
- ▶ Adjust the settings as desired.

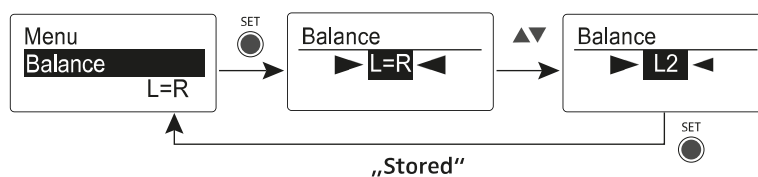

- ▶ Press the **SET** button to save the changes you made to the settings. **OR**
- ▶ Press the **ESC** button to cancel the entry without saving the setting.



Mode menu item

In the Mode menu item you can switch between Stereo and Focus.

Stereo mode

- i** The left-right signals are available as usual.
The Balance setting serves to adjust the balance between the left and right stereo signal. See [Balance menu item](#).

- ▶ To use it, activate Stereo mode on the corresponding SR IEM G4 transmitter. See [Mode menu item](#).

Focus mode

- ▶ The corresponding SR IEM G4 transmitter operates in Stereo mode:
 - The left-right signals are mixed and are available as a mono signal in both headphone channels.
 - The balance setting serves to adjust the relative levels of the two separate channels in the mixed mono signal. See [Balance menu item](#).
- ▶ The corresponding SR IEM G4 transmitter operates in Mono mode:
Only the left audio input of the SR IEM G4 is received as a mono signal.

To open the Mode menu item:

- ▶ On the home screen, press the **SET** button to open the operating menu.
- ▶ Press the **UP** or **DOWN** button until the Squelch menu item appears in the selection frame.
- ▶ Press the **SET** button to open the menu item.
- ▶ Adjust the settings as desired.

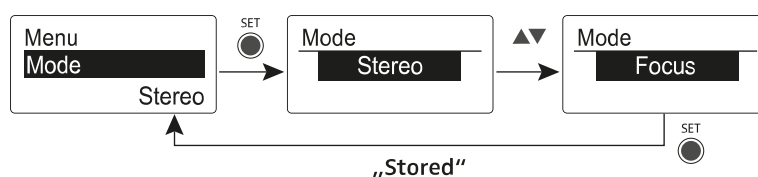



- ▶ Press the **SET** button to save the changes you made to the settings. **OR**
- ▶ Press the **ESC** button to cancel the entry without saving the setting.



High Boost menu item

In the High Boost menu item you can change the treble boost of the output signal.

Setting range:

- 8 dB at 10 kHz

To open the High Boost menu item:

- ▶ On the home screen, press the **SET** button to open the operating menu.
- ▶ Press the **UP** or **DOWN** button until the Squelch menu item appears in the selection frame.
- ▶ Press the **SET** button to open the menu item.
- ▶ Adjust the settings as desired.

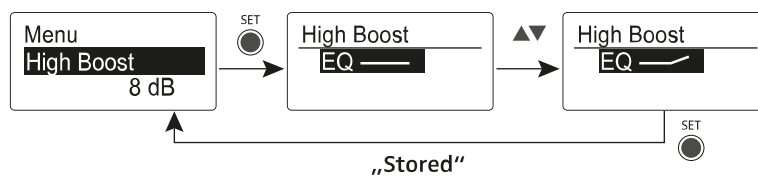

- ▶ Press the **SET** button to save the changes you made to the settings. **OR**
- ▶ Press the **ESC** button to cancel the entry without saving the setting.



Auto Lock menu item

In the Auto Lock menu item you can activate or deactivate auto lock-off function.

- i** You can find information about temporarily deactivating the lock-off function during operation under [Lock-off function](#).

To open the Auto Lock menu item:

- ▶ On the home screen, press the **SET** button to open the operating menu.
- ▶ Press the **UP** or **DOWN** button until the Squelch menu item appears in the selection frame.
- ▶ Press the **SET** button to open the menu item.
- ▶ Adjust the settings as desired.

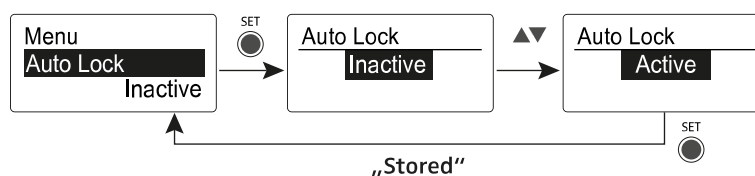

- ▶ Press the **SET** button to save the changes you made to the settings. **OR**
- ▶ Press the **ESC** button to cancel the entry without saving the setting.



Advanced menu item

In the Advanced submenu you can configure enhanced settings.

To open the Advanced submenu:

- ▶ On the home screen, press the SET button to open the operating menu.
- ▶ Press the UP or DOWN button until the Advanced menu item appears in the selection frame.
- ▶ Press the SET button to open the menu item.

Adjusting the receiving frequency for the frequency bank U

- see [Advanced -> Tune menu item](#)

Adjusting the limiter

- see [Advanced -> Limiter menu item](#)

Adjusting the volume boost

- see [Advanced -> Volume Boost menu item](#)

Adjusting the contrast of the display panel

- see [Advanced -> LCD Contrast menu item](#)

Adjusting the menu item and loading profiles

- see [Advanced -> Engineer Mode menu item](#)

Resetting the receiver

- see [Advanced -> Reset menu item](#)

Displaying the current software revision

- see [Advanced -> Software Revision menu item](#)



Advanced -> Tune menu item

In the Tune menu item of the Advanced submenu, you can configure the receiving frequencies for the frequency banks U1 to U6.

You can save a total of 16 frequencies in every U frequency bank.

Only adjusting the frequency

- ▶ Open the Tune menu item in the Advanced menu.
- ▶ Adjust the settings.

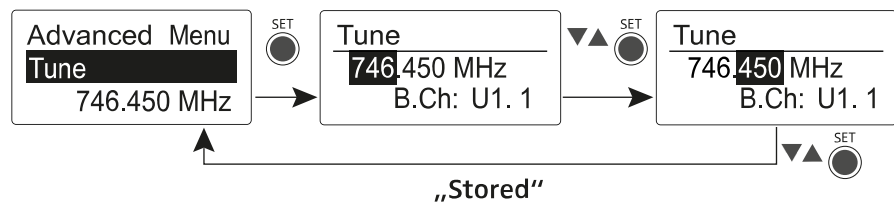

- ▶ Press the **SET** button to save the changes you made to the settings. **OR**
- ▶ Press the **ESC** button to cancel the entry without saving the setting.

Setting the channel and frequency

- ▶ Select the Tune menu item and call it up by holding down the SET button until the channel selection appears.
- ▶ Adjust the settings.

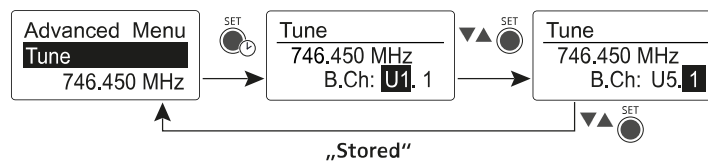

- ▶ Press the **SET** button to save the changes you made to the settings. **OR**
- ▶ Press the **ESC** button to cancel the entry without saving the setting.



Advanced -> Limiter menu item

In the Limiter menu item of the Advanced submenu, you can adjust the volume of the headphone output PHONES.

WARNING



Risk of hearing damage

The limiter limits the volume of the headphone output PHONES and thus protects your hearing. When the limiter is switched off, you may expose yourself to high volumes over a prolonged period which can cause permanent hearing damage.

- ▶ Set the limiter to the lowest level before putting the earphones on.
- ▶ Do not continuously expose yourself to high volume levels.

Setting range:

- Off
- -18 dB, -12 dB or -6 dB

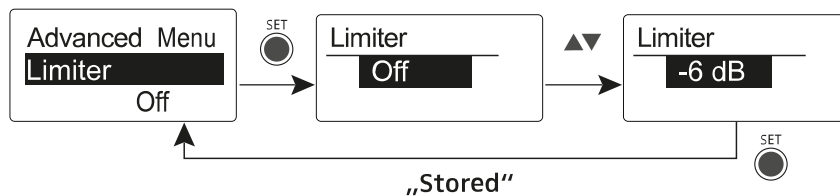



Advanced -> Volume Boost menu item

In the Volume Boost menu item of the Advanced submenu, you can adjust the volume boost.

Setting range:

- 0 dB, +3 dB or +6 dB

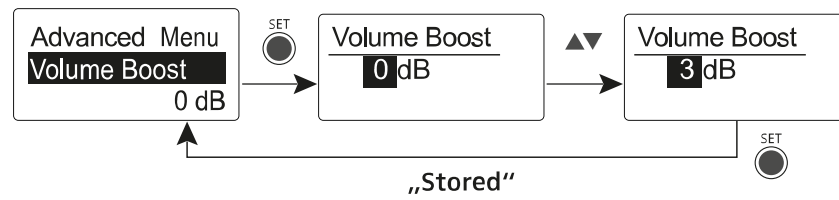

i When configuring the settings, ensure that the audio signal is not distorted.



Advanced -> LCD Contrast menu item

In the LCD Contrast menu item of the Advanced submenu, you can adjust the display contrast of the display panel.

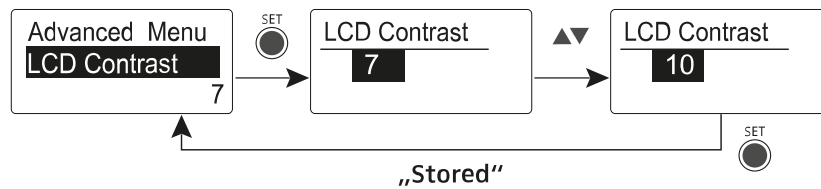



Advanced -> Engineer Mode menu item

In the Engineer Mode menu item of the Advanced submenu, you can configure the menu items and upload profiles.

In Engineer Mode, you can use your EK IEM G4 to read out settings from other EK receivers and save them as profiles.

You can load these profiles during a live transmission in order to monitor and, if necessary, adjust an audio signal reproduced by a read-out EK receiver.

A profile contains the settings of the menu items:

- [Squelch menu item](#)
- [Frequency Preset menu item](#)
- [Name menu item](#)
- [Balance menu item](#)
- [Mode menu item](#)
- [High Boost menu item](#)
- [Advanced -> Tune menu item](#)
- [Advanced -> Limiter menu item](#)
- [Advanced -> Volume Boost menu item](#)

Profiles List menu item

- Create up to 16 profiles and read out the settings of the different EK receivers.

Load Profiles menu item

- Activate/deactivate profile loading

Clear List menu item

- Delete all profiles

Profiles List - To read out settings and save them as a profile:

- ▶ Call up the Engineer Mode menu item in the Advanced menu.
- ▶ Call up the Profiles List menu item.
- ▶ Select an unused profile (a profile without a frequency entry).
- ▶ Press the **SET** button.
 - ✓ Sync appears on the display panel of the receiver.
- ▶ Place the receiver's infra-red interface in front of the infra-red interface of another EK receiver.
 - ✓ The settings of the receiver are assigned to the selected profile.



- ▶ Repeat this procedure to create profiles of other EK receivers.
You can read out the data of an SR IEM transmitter in the same way. Please note, however, that these settings will only be up-to-date if transmitter and receiver have been synchronized before ([Synchronizing devices](#)).
When the factory default settings are restored ([Advanced -> Reset menu item](#)), all profiles are deleted.

Load Profiles - To select a saved profile:

- ▶ Call up the Load Profiles menu item in the Engineer Mode submenu.
- ▶ Select Active to activate the loading of the profiles.
 - ✓ E appears on the standard display.
- ▶ Press the **ESC** button to exit the menu item.
- ▶ Select a profile by pressing the **UP/DOWN** button on the standard display.
 - ✓ The selected profile is loaded; you hear the audio signal of the corresponding receiver.

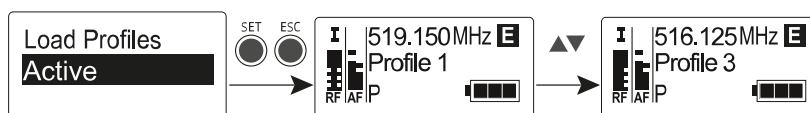

i If there is no profile saved, Inactive appears in the Load Profiles menu item. Engineer Mode remains activated, even if you replace the batteries or switch the EK off and on again.



Advanced -> Reset menu item

In the Reset menu item of the Advanced submenu, you can reset the settings of the receiver to the factory settings.

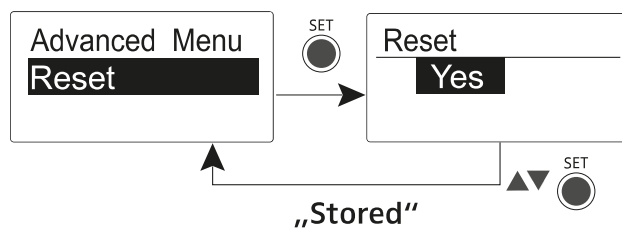



Advanced -> Software Revision menu item

In the Software Revision menu item of the Advanced submenu, you can display the current software version of the receiver.



SR IEM G4 stereo transmitter

Product overview

Front

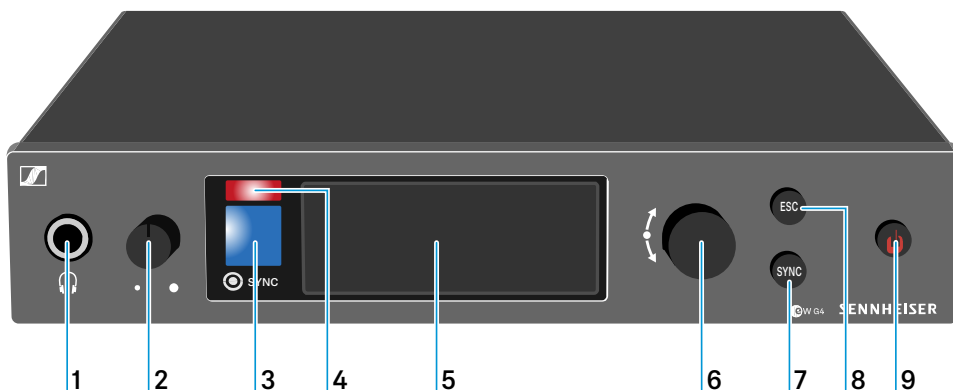

- 1 Headphone socket
see [Using the headphone output](#)
- 2 Volume control for the headphone socket
see [Using the headphone output](#)
- 3 Infrared interface with a blue LED
see [Synchronizing devices](#)
- 4 Red LED for warnings
see [Advanced > Fullscreen Warnings menu item.](#)
- 5 Display
see [Displays on the SR IEM G4 display panel](#)
- 6 Jog dial for navigating through the menu
see [Buttons for navigating the SR IEM G4 menu](#)
- 7 SYNC button
see [Synchronizing devices](#)
- 8 ESC button
see [Buttons for navigating the SR IEM G4 menu](#)
- 9 STANDBY button
see [Switching the SR IEM G4 on and off](#)



Back

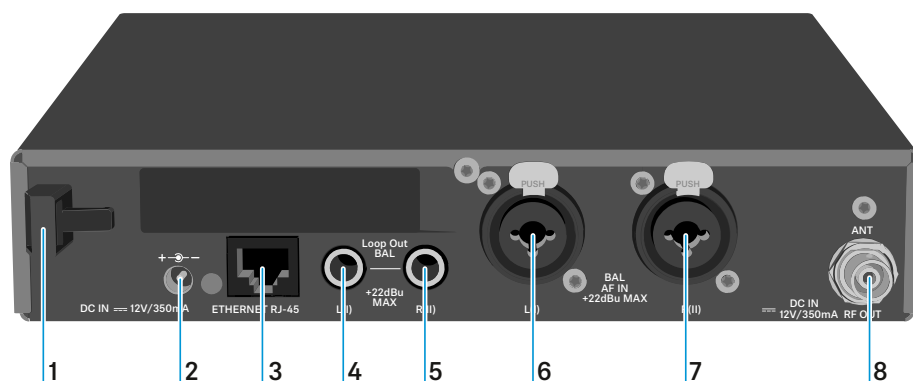

- 1 Strain relief for the cable of the power supply unit
see [Connecting/disconnecting the SR IEM G4 with/from the power supply](#)
- 2 DC IN socket
For connecting the power supply unit
see [Connecting/disconnecting the SR IEM G4 with/from the power supply](#)
- 3 LAN connection socket (ETHERNET RJ45)
see [Creating a data network](#)
- 4 6.3 mm jack socket LOOP OUT BAL L(I)
Audio output, left
see [Daisy chaining audio signals](#)
- 5 6.3 mm jack socket LOOP OUT BAL R(II)
Audio output, right
see [Daisy chaining audio signals](#)
- 6 XLR-3/6.3 mm jack combo socket BAL AF IN L(I)
Audio input, left
see [Connecting audio signals](#)
- 7 XLR-3/6.3 mm jack combo socket BAL AF IN R(II)
Audio input, right
see [Connecting audio signals](#)
- 8 RF OUT BNC socket
Antenna output with remote power supply input
see [Connecting antennas](#)



Connecting/disconnecting the SR IEM G4 with/from the power supply

Only use the supplied power supply unit. It is designed for your receiver and ensures safe operation.

To connect the SR IEM G4 transmitter to the power supply:

- ▶ Insert the plug of the power supply unit into the DC IN socket of the receiver.
- ▶ Pass the cable of the power supply unit through the cable grip.
- ▶ Slide the supplied country adapter onto the power supply unit.
- ▶ Plug the power supply unit into the wall socket.

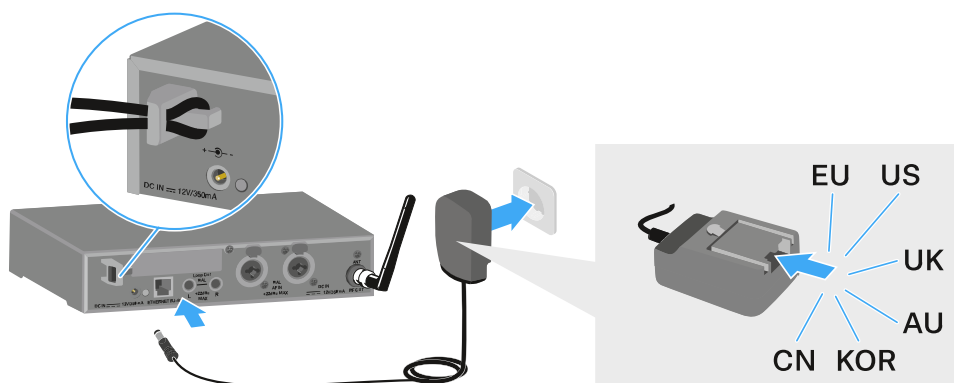

To disconnect the SR IEM G4 transmitter from the power supply:

- ▶ Unplug the power supply unit from the wall socket.
- ▶ Unplug the power supply unit from the DC IN socket of the receiver.



Creating a data network

You can monitor and control one or more SR IEM G4s via a network connection using Sennheiser Wireless Systems Manager (WSM) software.

i Automatic frequency setup can also be performed over the network without the WSM software. See [Easy Setup menu item](#).

To connect the SR IEM G4 to a network:

- ▶ Connect a network cable with an RJ45 connector (to the Ethernet socket on the rear side of the SR IEM G4).
- ▶ Connect the other end of the network cable to a network switch.

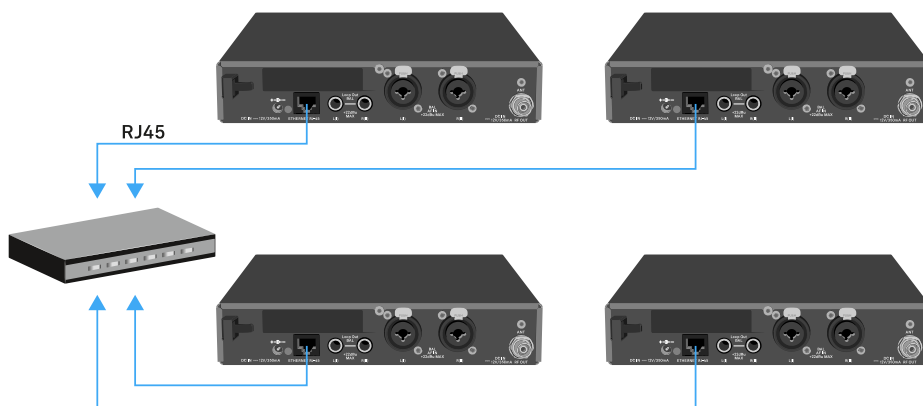

For more information about controlling devices via the Sennheiser Wireless Systems Manager (WSM) software, refer to the instruction manual for the software. You can download the software here: sennheiser.com/wsm.



Connecting audio signals

You can connect mono or stereo signals via the two input sockets BAL AF IN L(I) and BAL AF IN R(II).

To do so, the SR IEM G4 must be configured for mono or stereo operation in the menu. See [Mode menu item](#).

i In stereo mode, you can receive the two input signals either as a mixed mono signal or as a stereo signal. To do so, you must select Focus or Stereo mode on the EK IEM G4 receiver. See [Mode menu item](#).

Mono

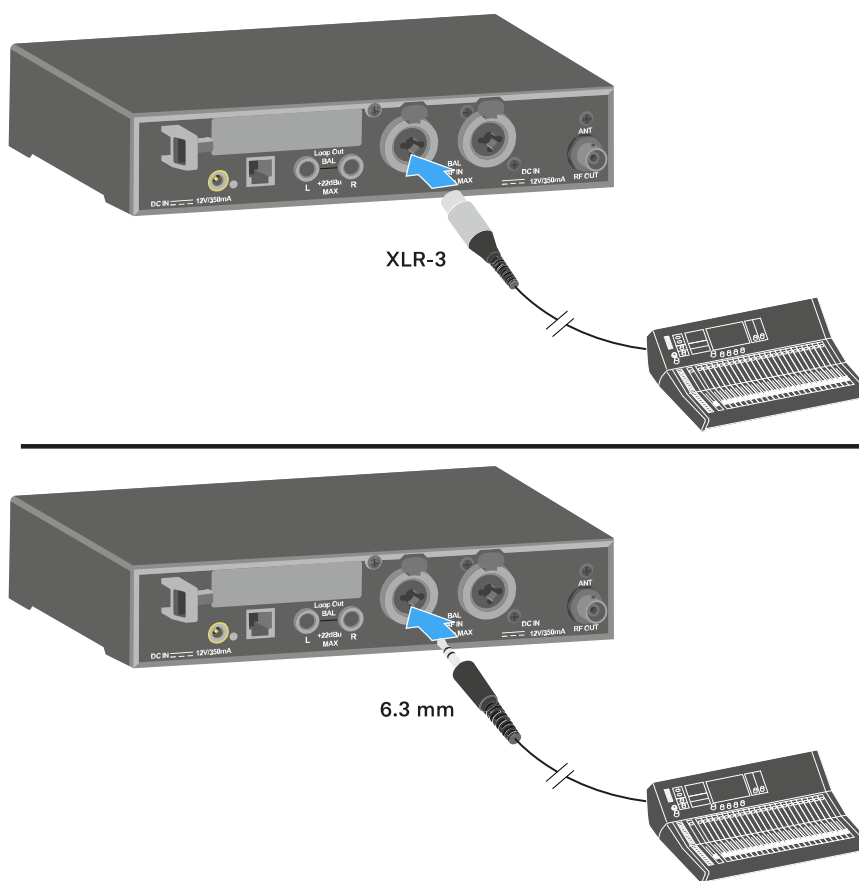

- ▶ Connect the output of an external device (e.g. a mixing console or another SR IEM G4) to the audio input socket BAL AF IN L(I) + MONO using a suitable cable.

i In mono mode, the corresponding EK IEM G4 receiver must be operated in Focus mode. See [Mode menu item](#).



Stereo

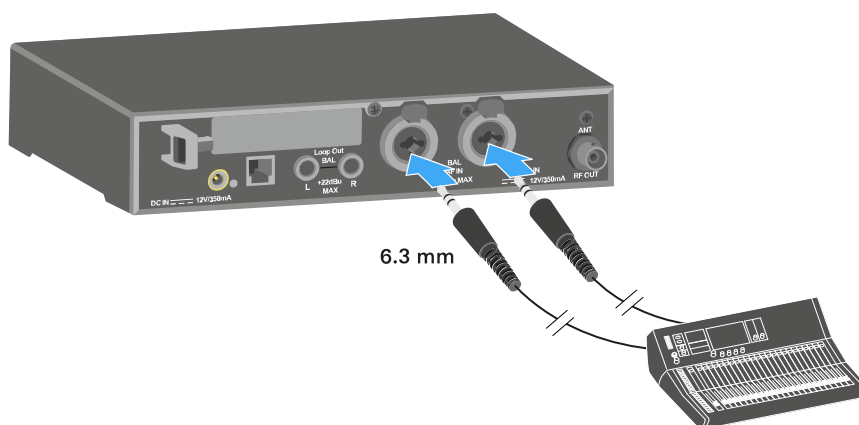
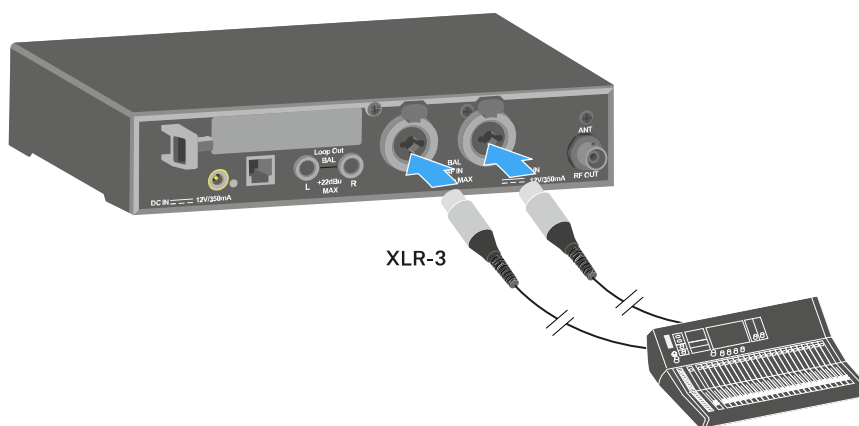

- ▶ Connect the output of an external device (e.g. a mixing console or another SR IEM G4) to the audio input sockets BAL AF IN L(I) and BAL AF IN R(II) using suitable cables.

i In stereo mode, the corresponding EK IEM G4 receiver can be operated in Focus mode or Stereo mode. See [Mode menu item](#).



Daisy chaining audio signals

Using the LOOP OUT BAL L and/or LOOP OUT BAL R output sockets, it is possible to transmit a signal that you want to make available to all receivers from the mixing console to a transmitter and then to daisy chain this signal from the transmitter to the other transmitters.

In this way, for example, you can distribute an AUX path from the mixing console in Focus mode to multiple transmitters and output a separate signal on the other channel of the same transmitter (e.g. for the individual musician).

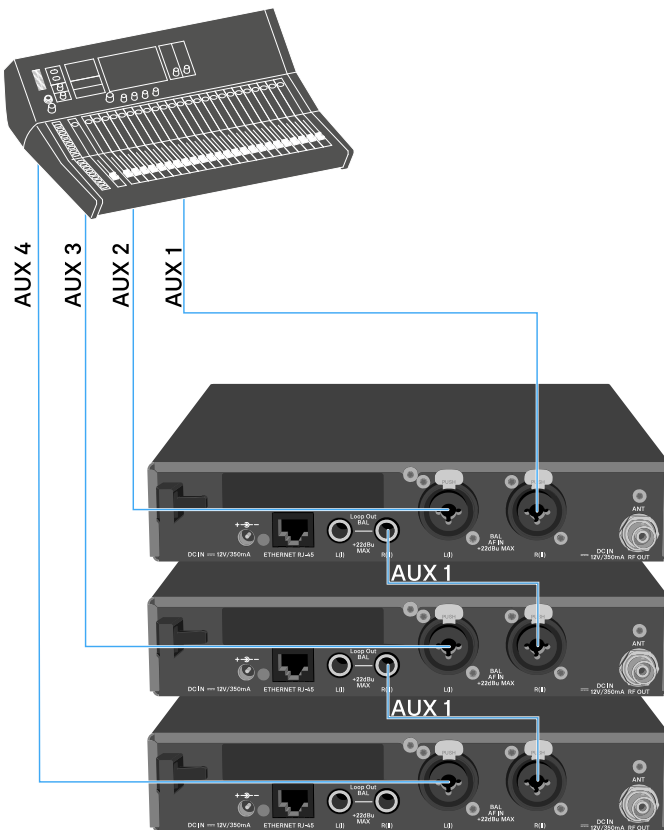

- ▶ Transmit a signal from the mixing console to the input socket of transmitter **A** (in this example: BAL AF IN R).
- ▶ Connect the LOOP OUT BAL R output socket of transmitter **A** with the BAL AF IN R input socket of transmitter **B**.
- ▶ Now connect the LOOP OUT BAL R output socket of transmitter **B** with the BAL AF IN R input socket of transmitter **C**.
- ▶ Continue on in this way for the remaining transmitters.



Connecting antennas

To connect the supplied rod antenna:

- ▶ Connect the rod antenna to the RF OUT socket on the rear side of the SR IEM G4.

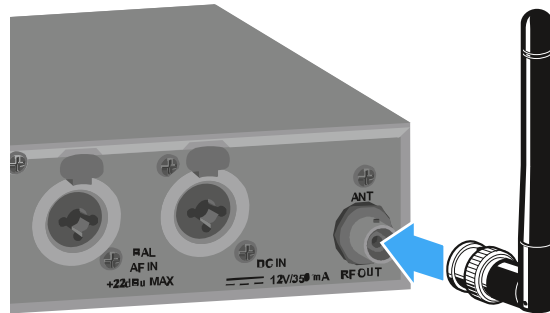

- i** If you are using more than one transmitter, we recommend using remote antennas and the AC 41 antenna combiner. You can find more information here: [AC 41 antenna combiner](#).



Installing the SR IEM G4 in a rack

NOTICE



Rack mounting poses risks

When installing the device in a closed or multi-rack assembly, please consider that, during operation, the ambient temperature, the mechanical loading and the electrical potentials will be different from those of devices which are not mounted into a rack.

- ▶ Make sure that the ambient temperature within the rack does not exceed the permissible temperature limit specified in the specifications. See [Specifications](#).
- ▶ Ensure sufficient ventilation; if necessary, provide additional ventilation.
- ▶ Make sure that the mechanical loading of the rack is even.
- ▶ When connecting to the power supply system, observe the information indicated on the type plate. Avoid circuit overloading. If necessary, provide overcurrent protection.
- ▶ When rack mounting, please note that intrinsically harmless leakage currents of the individual power supply units may accumulate, thereby exceeding the allowable limit value. As a remedy, ground the rack via an additional ground connection.

i To mount the transmitter in a rack, you will need the GA 3 rack mounting kit [Rack mount kit](#) (optional accessory).

Mounting a single transmitter in a rack

- ▶ Unscrew and remove the two recessed head screws (M4x8) on each side of the transmitter.
- ▶ Secure the left and right mounting angles to the sides of the transmitter using the previously removed recessed head screws.

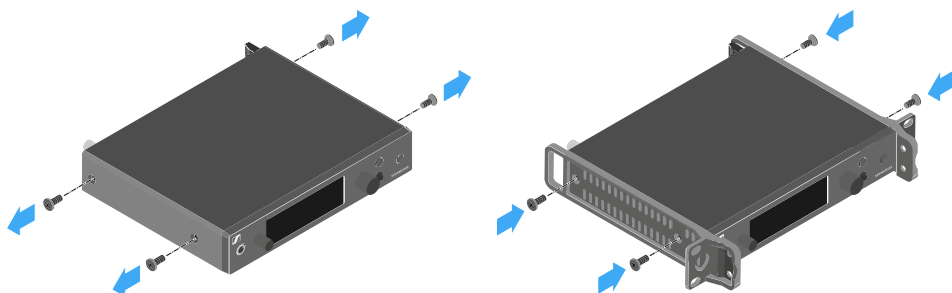

- ▶ Secure the blanking plate to one of the mounting angles using two recessed head screws (M6x10).

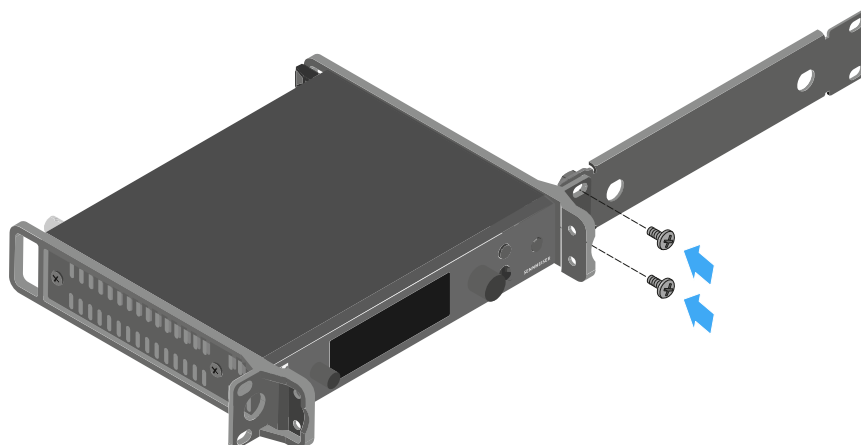

- ▶ Attach the antenna. You have the following options:
 - Connect the supplied rod antenna on the rear side of the transmitter. In this case, cover the antenna holes with the two covers (left diagram).
 - Attach the AM 2 antenna front mounting set (optional accessory) and mount the rod antenna on the blanking plate (right diagram).



- Use a remote antenna, possibly in combination with the AC 41 antenna combiner.

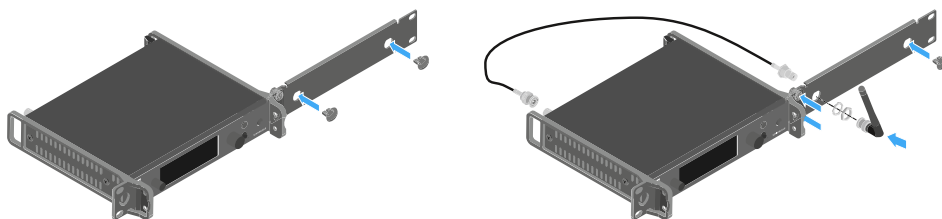

i If you are using more than one transmitter, we recommend using remote antennas and, as needed, Sennheiser antenna accessories. For more information, visit the ew G4 product page at [sennheiser.com](https://www.sennheiser.com).

- ▶ Slide the transmitter with the mounted blanking plate into the 19" rack.
- ▶ Secure the mounting angle and the blanking plate to the 19" rack.
- ▶ Align the mounted antennas in a V-shape.

Mounting two receivers side by side in a rack

i If you want to mount two transmitters side by side, you can mount the antennas to the front of the rack in combination with the AC 41 antenna combiner. Otherwise, you can use the ASA 1 antenna splitter in combination with the [Antenna front mounting kit](#) front mounting kit and an additional [Rack mount kit](#) rack mounting kit. For more information, visit the ew G4 product pages at [sennheiser.com](https://www.sennheiser.com).

- ▶ Place both transmitters upside down and side by side on an even surface.
- ▶ Secure the jointing plate to the transmitters using the six recessed head screws (M3x6).
- ▶ Secure the mounting angle.

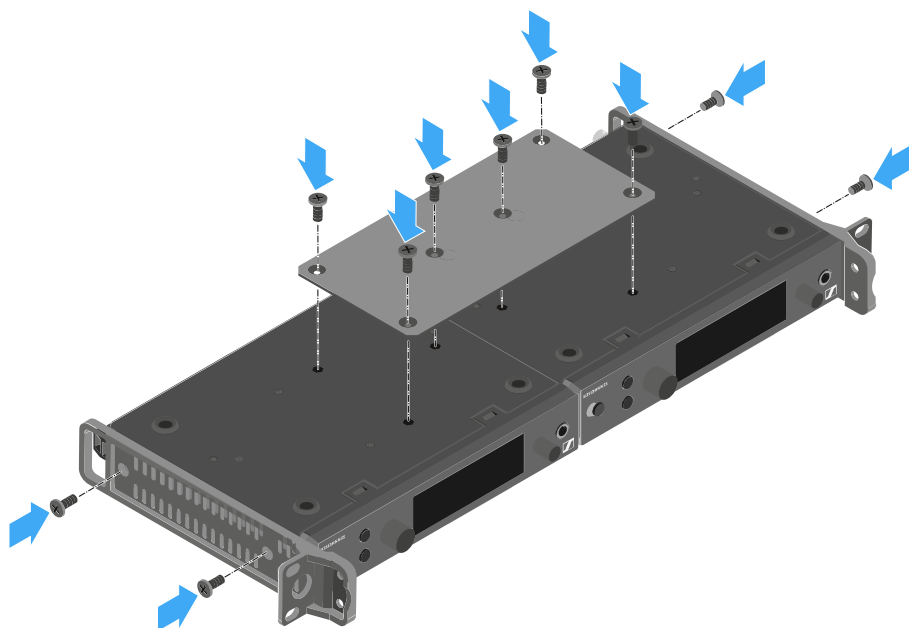

- ▶ Slide the connected transmitters into a 19" rack.
- ▶ Secure the mounting angle to the 19" rack.



Switching the SR IEM G4 on and off

To switch on the transmitter:

- ▶ Short-press the **STANDBY** button.
- ✔ The transmitter switches on and the standard display appears.



To switch the transmitter to standby mode:

- ▶ If necessary, deactivate the lock-off function (see [Lock-off function](#)).
- ▶ Press and hold the **STANDBY** button until OFF appears on the display panel.
- ✔ The display panel switches off.

To completely switch the transmitter off:

- ▶ Disconnect the transmitter from the power supply system by unplugging the power supply unit from the wall socket.



Using the headphone output

You can use the headphone output on the front of the SR IEM G4 (6.3 mm jack) to listen to the audio signal.

WARNING



Danger due to high volume levels

Volume levels that are too high may damage your hearing.

- ▶ Turn down the volume of the headphone output before you put on the headphone.

- ▶ Connect the headphone to the headphone socket.
- ▶ Control the volume by turning the volume control next to the headphone socket.

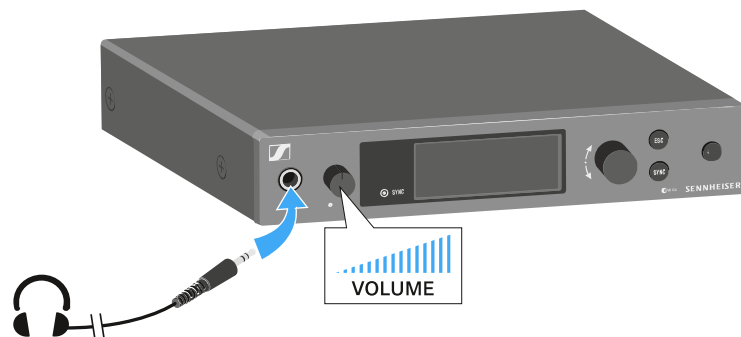



Configuring the audio channels (mono/stereo)

You can configure audio channels in the [Mode menu item](#). You can select either Stereo or Mono:

- ▶ Select Stereo when you want to send a separate audio signal on channel I and channel II (e.g. channel I = audio signal of the moderator/musician, channel II = sum of all audio signals).
- ✓ The moderator/musician then has the option to adjust the volume distribution on his or her receiver as needed.

i In Stereo mode, you can receive the two input signals either as a mixed mono signal or as a stereo signal. To do so, you must select Focus or Stereo mode on the EK IEM G4 receiver.

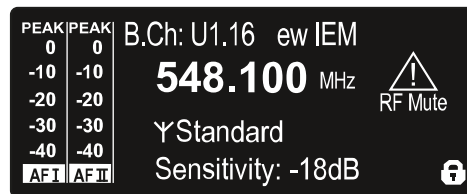

- ▶ Select Mono when you only want to transmit one channel. The signal of the left audio input BAL AF IN L is used.

i In Mono mode, you have to deactivate the pilot tone evaluation on your EK IEM G4 receiver. This is the only way to ensure that your receivers will transmit the same signal on channel I and channel II.

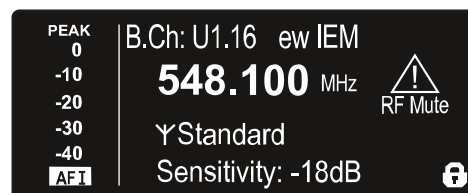



Deactivating the RF signal (RF mute)

To deactivate the RF signal:

- ▶ Press the **STANDBY** button.
 - ✓ RF Mute Off? appears in the display panel.
- ▶ Turn the **jog dial**.
 - ✓ RF Mute ON? appears in the display panel.
- ▶ Press the **jog dial**.
 - ✓ The transmission frequency is displayed, however the transmitter is not transmitting an RF signal. The RF Mute warning appears (see [Displays on the SR IEM G4 display panel](#)) and the LED warnings are illuminated (see [Product overview](#)).

To activate the RF signal:

- ▶ Press the **STANDBY** button.
 - ✓ RF Mute Off? appears in the display panel.
- ▶ Turn the **jog dial**.
 - ✓ RF Mute ON? appears in the display panel.
- ▶ Press the **jog dial**.



- ✓ The warning in the display and the LED warnings go out.

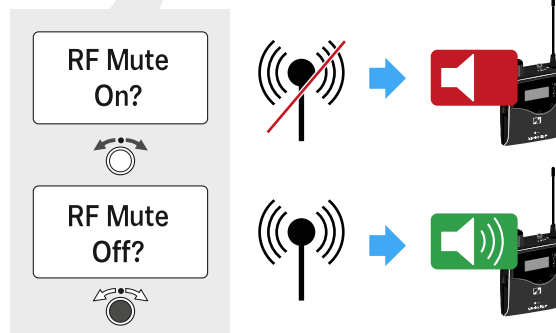



Lock-off function

You can set the automatic lock-off function in the Auto Lock menu (see [Auto Lock menu item](#)).

When you have switched on the lock-off function, you will have to turn the transmitter off and on again in order to operate it.

To temporarily deactivate the lock-off function:

- ▶ Press the **jog dial**.
 - ✓ Locked appears in the display panel.
- ▶ Turn the **jog dial**.
 - ✓ Unlock? appears in the display panel.
- ▶ Press the **jog dial**.
 - ✓ Lock-off function is now temporarily deactivated.

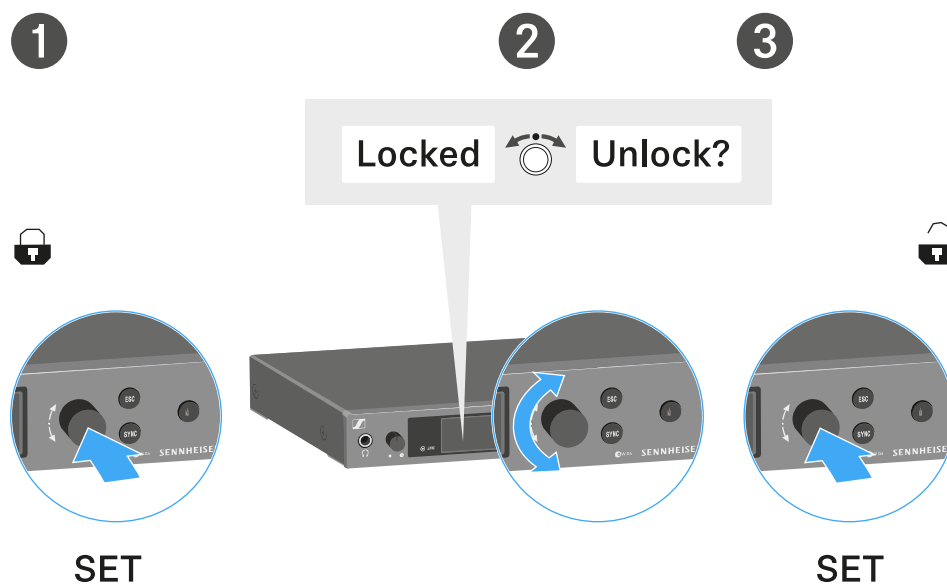

When you are in the operating menu

- Lock-off function is deactivated long enough for you to work in the operating menu.

When one of the standard displays is shown

- Lock-off function is automatically activated after 10 seconds.

The lock-off function icon flashes while the lock-off function is activated again.



Displays on the SR IEM G4 display panel

You can view the following information on the transmitter display.

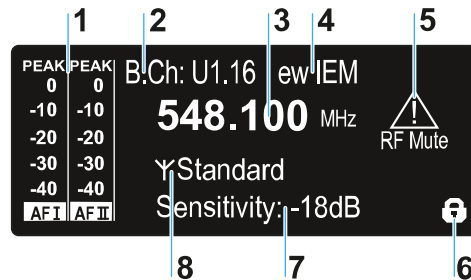

1 AF audio level (audio frequency)

Audio channel level with peak hold function

When the display shows full deflection, the audio input level is excessively high. When the transmitter is overloaded frequently or for extended periods of time, the PEAK display is shown inverted

see [Sensitivity menu item](#)

see [Configuring the audio channels \(mono/stereo\)](#)

2 Frequency bank and channel

Current frequency bank and channel number

see [Frequency Preset menu item](#)

3 Frequency

Configured transmission frequency

see [Frequency Preset menu item](#)

4 Name

Freely selectable name of the receiver

see [Name menu item](#)

5 Warnings

Activated warning messages are displayed

see [Advanced > Fullscreen Warnings menu item.](#)

6 Lock-off function

Lock-off function is activated

see [Auto Lock menu item](#)



7 Input sensitivity

Configured input sensitivity for the NF signal on the audio input sockets BAL AF IN L (I) and BAL AF IN R (II)

see [Sensitivity menu item](#)

8 Transmission icon and transmission power

RF signal is being transmitted

see [Advanced > RF Power menu item](#)

see [Deactivating the RF signal \(RF mute\)](#)

The display is dimmed automatically after 2 minutes of inactivity.



If there is no radio link to a transmitter, the display switches off after 20 minutes. The display can be reactivated by pressing any button.

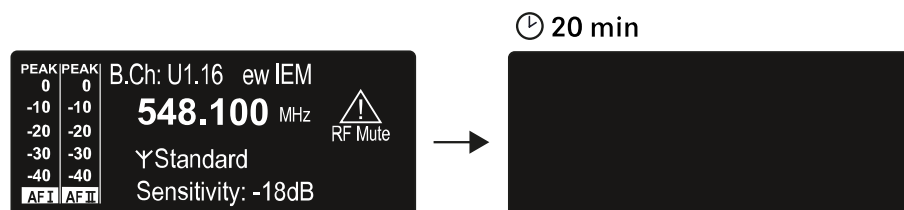



Buttons for navigating the SR IEM G4 menu

To open the menu:

- ▶ Press the **jog dial**.
 - ✔ The operating menu is shown on the transmitter display panel.
- ▶ Turn the **jog dial** to navigate through the individual menu items.
- ▶ Press the **jog dial** to open the selected menu item.

After you open a menu item, you can make changes as follows:

- ▶ Turn the **jog dial** to set the displayed value.
- ▶ Press the **jog dial** to save your setting.
- ▶ Press the **ESC** button to leave the menu item without saving the setting.



Menu structure

The figure shows the complete SR IEM G4 menu structure in an overview.

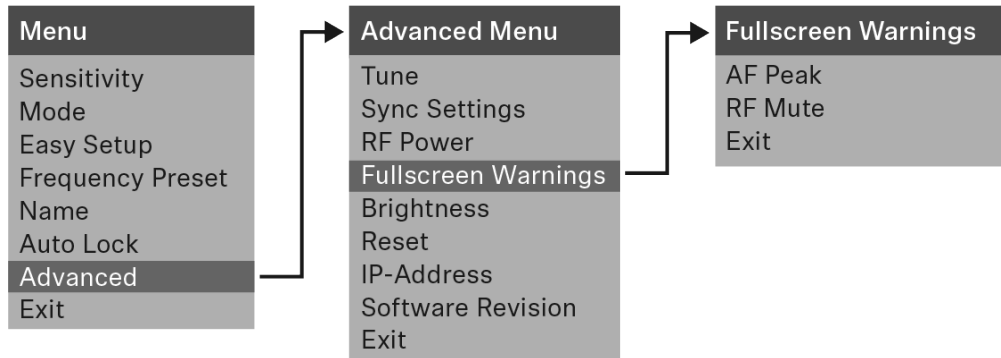



Setting options in the menu

Adjusting the input sensitivity

- see [Sensitivity menu item](#)

Configuring the audio transmission mode (mono/stereo)

- see [Mode menu item](#)

Activating Easy Setup Sync

- see [Easy Setup menu item](#)

Setting the frequency bank and the channel

- see [Frequency Preset menu item](#)

Entering a freely selectable name

- see [Name menu item](#)

Activating/deactivating the automatic lock-off function

- see [Auto Lock menu item](#)

Configuring enhanced settings in the Advanced Menu:

- Adjusting the transmission frequencies for the U frequency bank
- Adjusting the parameters for transmission to the receivers
- Configuring the transmission power
- Adjusting the warnings
- Adjusting the contrast of the display panel
- Resetting the transmitter
- Configuring the IP address
- Displaying the current software revision
- see [Advanced menu item](#)

Sensitivity menu item

Adjusting the input sensitivity – AF audio level

Setting range:

- 0 to -42 dB in steps of 3 dB

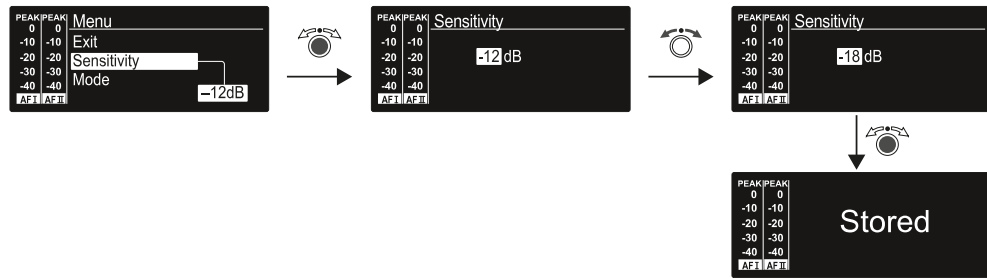



Mode menu item

Configuring the audio transmission

Setting range:

- Stereo and Mono

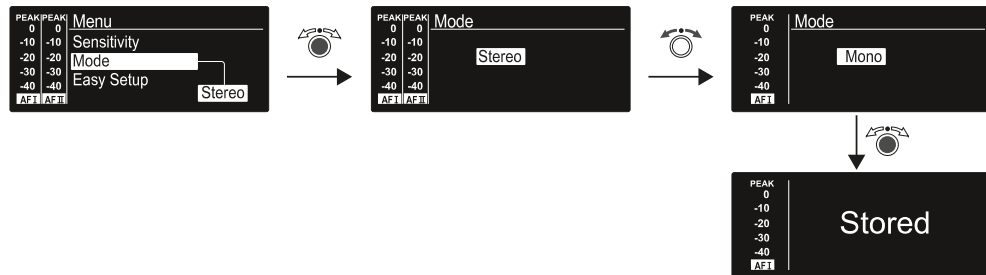

i In stereo mode, you can receive the two input signals either as a mixed mono signal or as a stereo signal. To do so, you must select Focus or Stereo mode on the EK IEM G4 receiver. See [Mode menu item](#).



Easy Setup menu item

Activating Easy Setup Sync

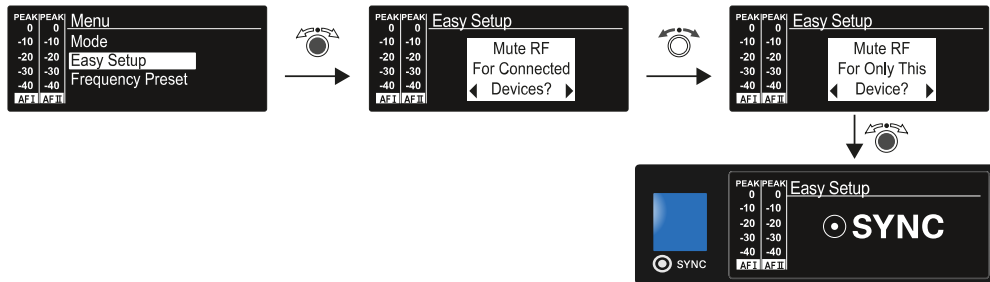

The Easy Setup Sync function is needed to perform a frequency scan using the receiver and for automatic multi-channel frequency setup.

- See [Easy Setup menu item](#) for the EK IEM G4 receiver.
- See [Synchronizing devices](#).



Frequency Preset menu item

Manually selecting a frequency bank and channel

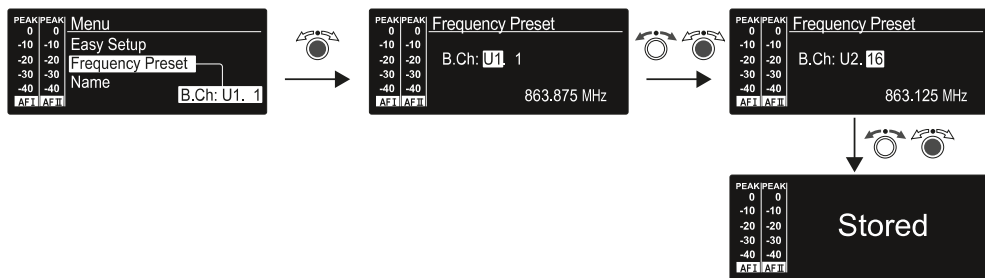



Name menu item

Entering names



In the Name menu item you can enter any name you want for the transmitters (e.g. the names of the musicians).

The names are a maximum of 8 characters:

- All letters except umlauts.
- Numbers from 0 to 9
- Special characters and spaces

Enter the names as follows:

- ▶ Turn the jog dial to select a character.
- ▶ Press the jog dial to switch to the next position.
- ✔ Once you have entered the last character, press the jog dial to save the name.



Auto Lock menu item

Switching the automatic lock-off function on and off

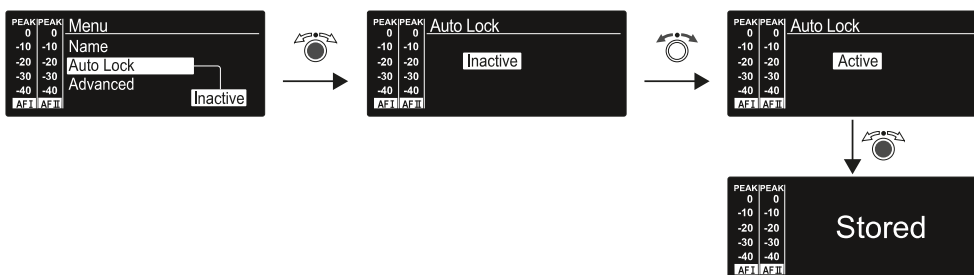

This lock prevents the transmitter from being unintentionally switched off and also prevents any unintentional changes to the transmitter's configuration. In the standard display, the lock icon shows whether the lock-off function is currently switched on.

- i** You can find information about using the lock-off function under [Lock-off function](#).



Advanced menu item

In the Advanced submenu you can configure enhanced settings.

Adjusting the transmission frequencies for the U frequency bank

- see [Advanced > Tune menu item](#)

Adjusting the parameters for transmission to the receivers

- see [Advanced > Sync Settings menu item](#)

Configuring the transmission power

- see [Advanced > RF Power menu item](#)

Adjusting the warnings

- see [Advanced > Fullscreen Warnings menu item.](#)

Adjusting the contrast of the display panel

- see [Advanced > Brightness menu item](#)

Resetting the transmitter

- see [Advanced > Reset menu item](#)

Configuring the IP address

- see [Advanced > IP Address menu item](#)

Displaying the current software revision

- see [Advanced > Software Revision menu item](#)



Advanced > Tune menu item

Configuring transmission frequencies and frequency banks U1 to U6.

You can save a total of 16 channels in the frequency banks U1 to U6.

Only adjusting the frequency

- ▶ Open the Tune menu item in the Advanced menu.
- ▶ Adjust the settings.

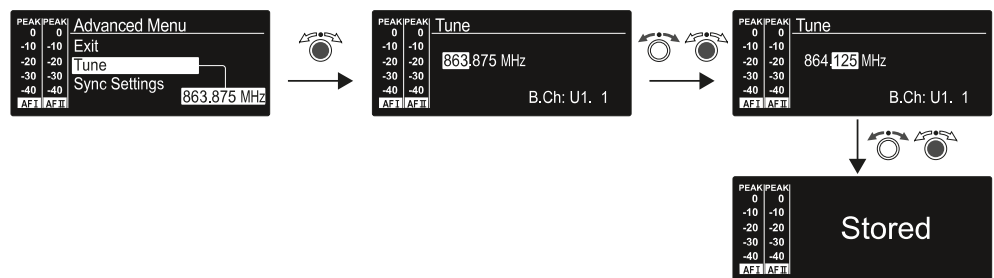

Setting the channel and frequency

- ▶ Select the Tune menu item and call it up by holding down the jog dial until the channel selection appears.

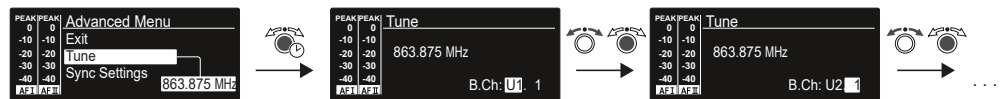

- ▶ Adjust the settings.



Advanced > Sync Settings menu item

Configuring, activating or deactivating parameters for transmission to the receivers.

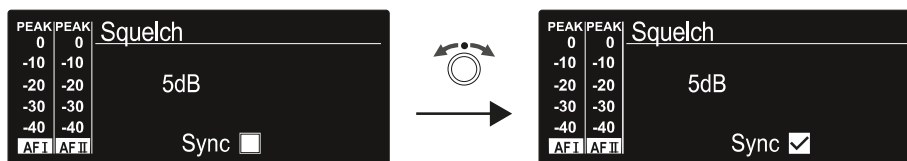

When the check box is activated, the value will be transmitted during synchronization. If it is deactivated, the value will not be transmitted.

You can configure and activate/deactivate the following parameters:

- Balance
- Squelch
- Mode
- High Boost
- Auto Lock
- Limiter

See [Synchronizing devices](#).



Advanced > RF Power menu item

Configuring the transmission power.

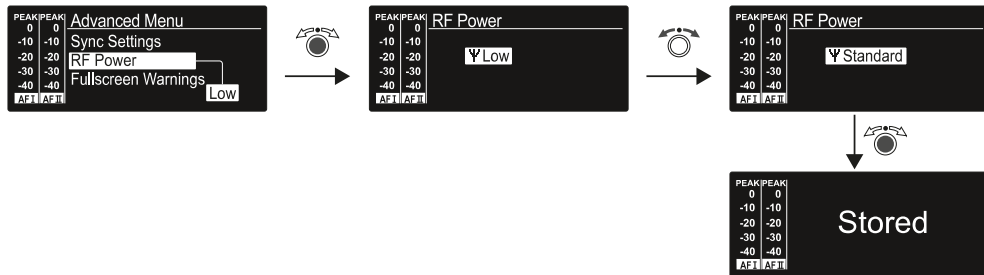

You can configure the transmission power in three steps in the RF Power menu item.

i Please note the information at the following address: sennheiser.com/sifa.

Setting range

- Low: 10 mW
- Standart: 30 mW
- High: 50 mW

i If you are using the AC 41 antenna combiner, the transmission power of the connected transmitters cannot be set to more than 30 mW (default) for legal reasons.



Advanced > Fullscreen Warnings menu item.

Activating/deactivating warnings

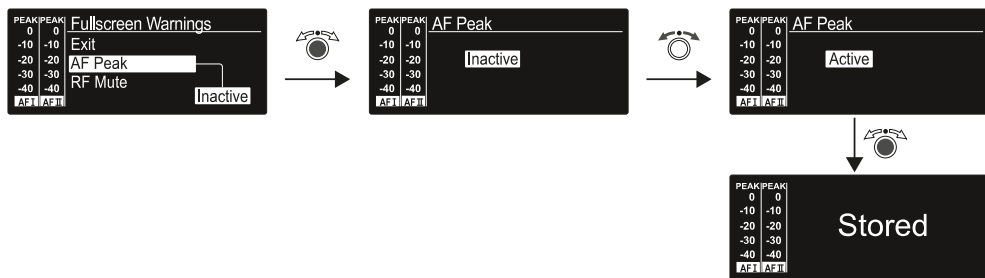

You can activate or deactivate the following warnings:

AF-Peak

- The audio level is too high.

RF Mute

- The RF signal from the transmitter to the receiver is deactivated.



Advanced > Brightness menu item

Adjusting the contrast of the display panel.

Setting range:

- 0 to 15

You can configure the contrast of the display in 16 steps.

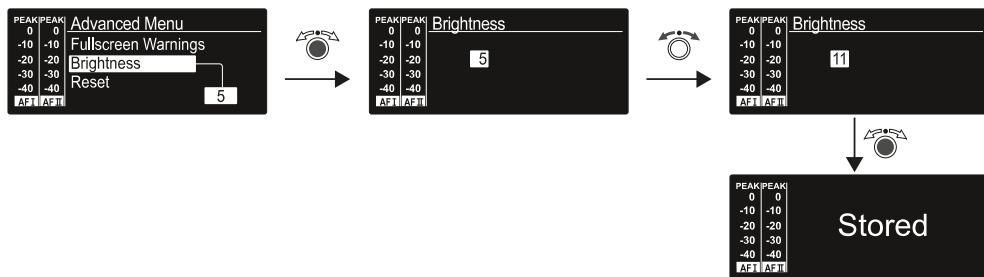



Advanced > Reset menu item

Resetting the transmitter.

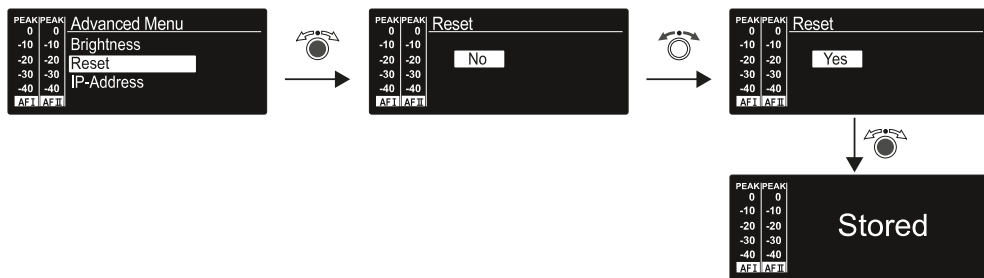

When you reset the transmitter, only the selected settings of the pilot tone and the U1 to U6 frequency banks are retained.



Advanced > IP Address menu item

Adjusting the network configuration.

Setting range:

- Automatic
- Manual

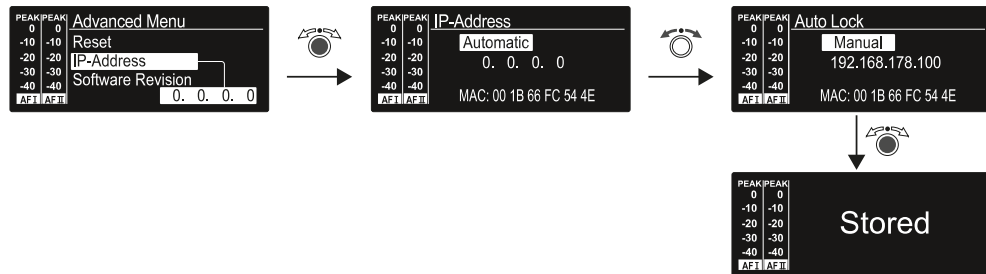



Advanced > Software Revision menu item

Show software revision.

You can display the current software revision.



AC 41 antenna combiner

Product overview

Front

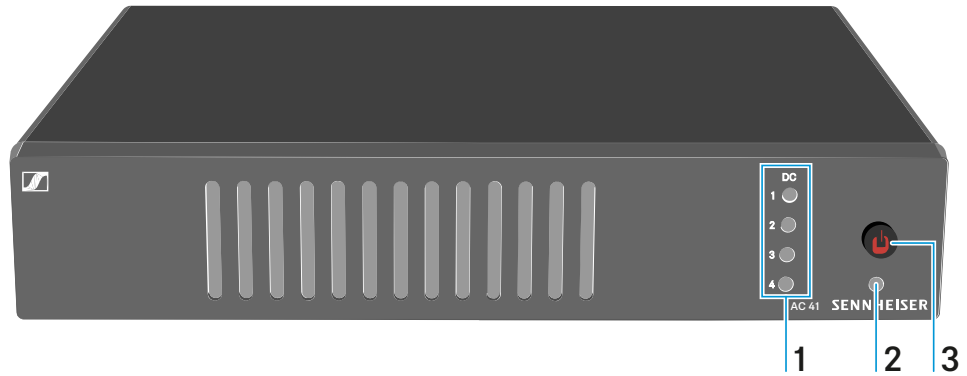

1 Status LEDs

Power supply of the transmitter

see [Meaning of the LEDs](#)

2 Power LED

see [Switching the AC 41 on and off](#)

3 ON/OFF button

see [Switching the AC 41 on and off](#)

Back

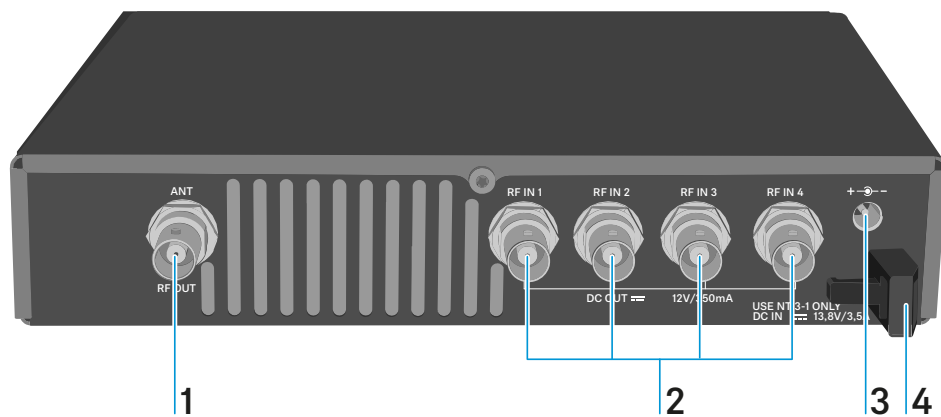



1 RF OUT BNC socket

Antenna output

see [Connecting antennas](#)

2 RF IN 1 to RF IN 4 BNC sockets

Antenna input with DC OUT

see [Connecting the AC 41 with transmitters](#)

3 DC IN socket

To connect the NT 3-1 power supply unit

see [Connecting/disconnecting the AC 41 to/from the power supply system](#)

4 Strain relief for the cable of the power supply unit

see [Connecting/disconnecting the AC 41 to/from the power supply system](#)



Connecting/disconnecting the AC 41 to/from the power supply system

To supply power to the AC 41, the connected transmitters and any antenna amplifiers used, you will need the NT 3-1 power supply unit.

Only use the supplied NT 3-1 power supply unit. It is designed for your antenna combiner and ensures safe operation.

To connect the AC 41 antenna combiner to the power supply system:

- ▶ Connect the hollow jack plug of the power supply unit to the DC IN socket of the antenna combiner.
- ▶ Pass the cable of the power supply unit through the cable grip.
- ▶ Plug the supplied mains cable into the power supply unit.
- ▶ Plug the mains cable into the wall socket.

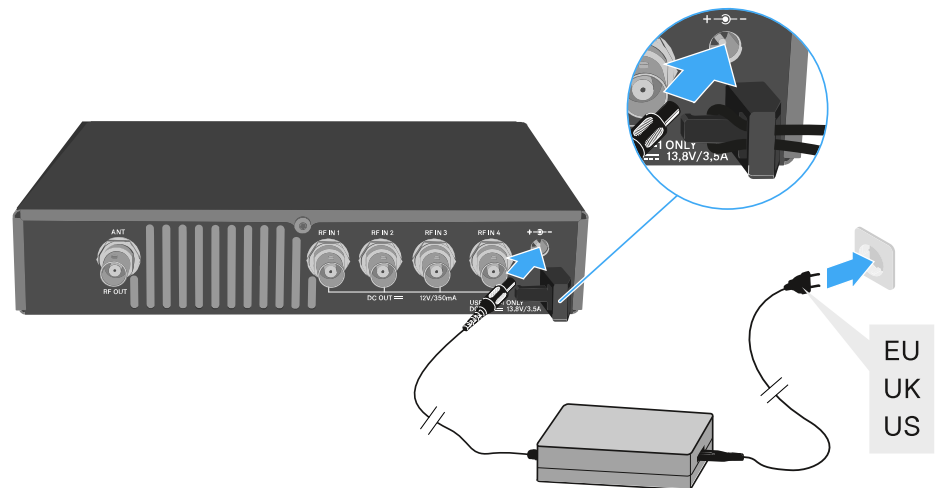

To completely disconnect the AC 41 antenna combiner from the power supply system:

- ▶ Unplug the mains cable from the wall socket.
- ▶ Unplug the hollow jack plug of the power supply unit from the DC IN socket of the antenna combiner.



Connecting the AC 41 with transmitters

You can connect and operate up to four stereo transmitters to the AC 41.

The following transmitters are compatible:

evolution wireless G4:

- SR IEM G4

evolution wireless G3:

- SR 300 IEM G3

Serie 2000 IEM:

- SR 2000 IEM (with its own power supply)
- SR 2050 IEM (with its own power supply)

i For legal reasons, the transmission power of the connected transmitters must be set to a maximum of 30 mW (standard) when operating the AC 41. See [Advanced > RF Power menu item](#).

To connect the transmitter to the antenna combiner:

- ▶ Connect one of the RF IN sockets of the AC 41 with the RF OUT jacks of a transmitter.
- ▶ Repeat the previous step until all four transmitters are connected to the antenna combiner.
- ▶ Connect the AC 41 to the power supply system (see [Connecting/disconnecting the AC 41 to/from the power supply system](#)).
- ✓ The LEDs light up (see [Meaning of the LEDs](#)).

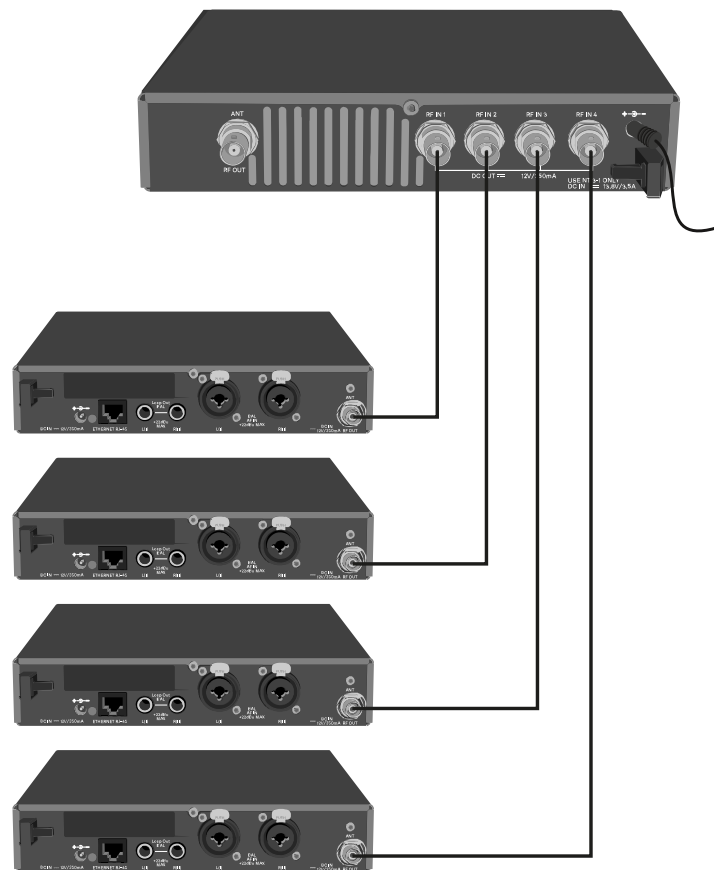

i The SR IEM G4 and SR 300 IEM G3 transmitters are supplied with voltage via the RF IN input sockets of the AC 41.



Connecting antennas

i For more information about antennas and antenna accessories, see [Antennas and accessories](#).

i In order to ensure optimal reception even in the case of poor reception conditions, we recommend using remote antennas.

To connect a remote antenna:

- ▶ Connect the antenna and transmitter with a low-attenuation 50-Ω cable.
- ▶ Use the shortest antenna cable possible with few intermediary connections. The cable and transmitter will attenuate the wanted signal.
- ▶ Place the antenna in the room where the transmission is taking place.
- ▶ Maintain a distance of at least 1 m (3 ft) between the antenna and any metal objects.

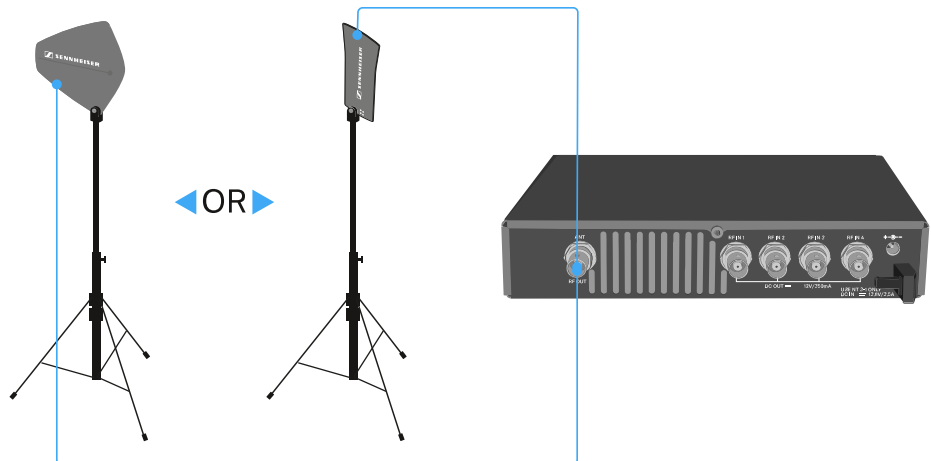



Installing the AC 41 in a rack

NOTICE



Rack mounting poses risks

When installing the device in a closed or multi-rack assembly, please consider that, during operation, the ambient temperature, the mechanical loading and the electrical potentials will be different from those of devices which are not mounted into a rack.

- ▶ Make sure that the ambient temperature within the rack does not exceed the permissible temperature limit specified in the specifications
- ▶ Ensure sufficient ventilation; if necessary, provide additional ventilation.
- ▶ Make sure that the mechanical loading of the rack is even.
- ▶ When connecting to the power supply system, observe the information indicated on the type plate. Avoid circuit overloading. If necessary, provide overcurrent protection.
- ▶ When rack mounting, please note that intrinsically harmless leakage currents of the individual power supply units may accumulate, thereby exceeding the allowable limit value. As a remedy, ground the rack via an additional ground connection.

Mounting a single antenna combiner in a rack:

i To mount the antenna combiner in a rack, you will need the GA 3 [Rack mount kit](#) (optional accessory).

- ▶ Unscrew and remove the two recessed head screws (M4x8) on each side of the antenna combiner.
- ▶ Secure the mounting angles to the sides of the antenna combiner using the previously removed recessed head screws.

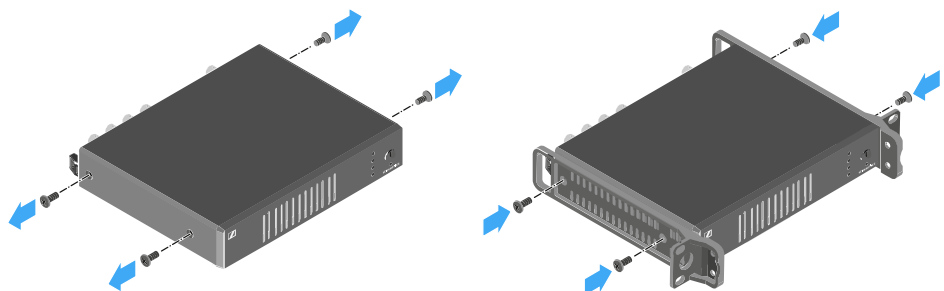



- ▶ Secure the blanking plate to one of the mounting angles using two recessed head screws (M6x10).
- ▶ Cover the antenna holes with the two covers.

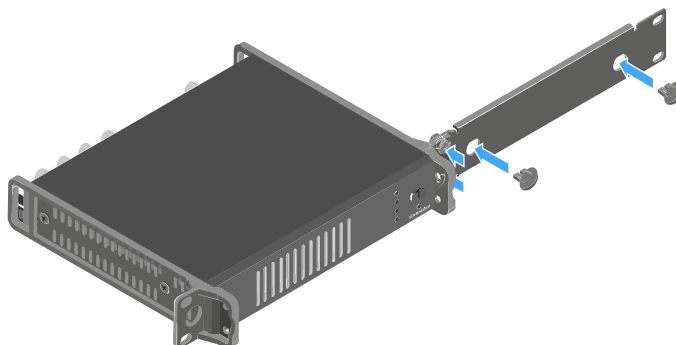

- ▶ Slide the antenna combiner with the mounted blanking plate into the 19" rack.
- ▶ Secure the mounting angle and the blanking plate to the 19" rack.

Mounting two antenna combiners side by side in a rack

i To mount the antenna combiner in a rack, you will need the GA 3 [Rack mount kit](#) (optional accessory).

- ▶ Place both antenna combiners upside down and side by side on an even surface.
- ▶ Secure the jointing plate to the transmitters using the six recessed head screws (M3x6).
- ▶ Secure the mounting angle.

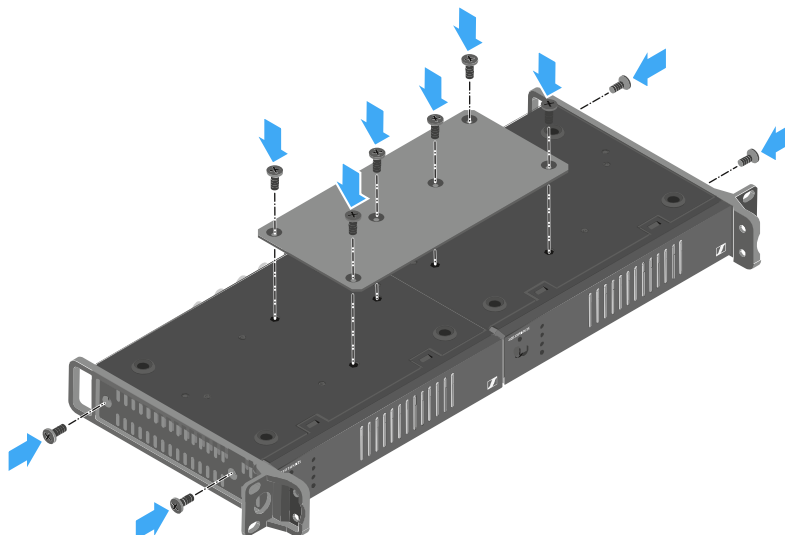



- ▶ Slide the connected antenna combiners into a 19" rack.
- ▶ Secure the mounting angle to the 19" rack.



Switching the AC 41 on and off

To switch on the antenna combiner:

- ▶ Short-press the **ON/OFF** button.
- ✓ The antenna combiner switches on and the power LED turns green. The transmitters receive the RF signal. The status LEDs light up (see [Meaning of the LEDs](#)).

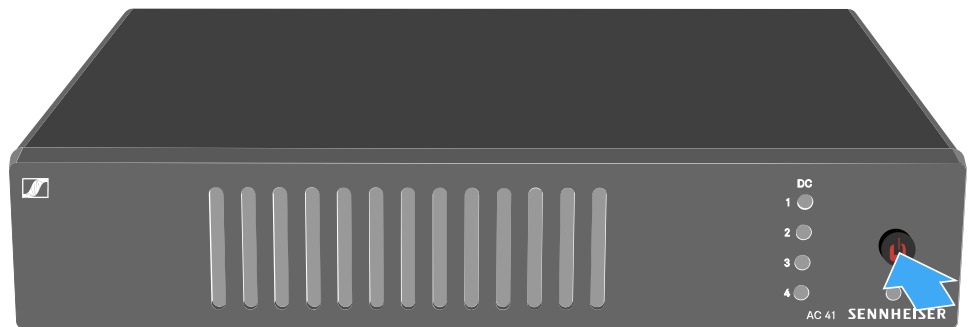

To switch the antenna combiner to standby mode:

- ▶ Hold down the **ON/OFF** button until the power LED turns off.

To fully switch off the antenna combiner:

- ▶ Disconnect the antenna combiner from the power supply system by unplugging the power supply unit from the wall socket.



Meaning of the LEDs

LEDs 1 to 4 are lit:

- The transmitters have been connected correctly as described under [Connecting the AC 41 with transmitters](#).
 - Sockets RF IN 1 to RF IN 4 have supply voltage for the transmitters.

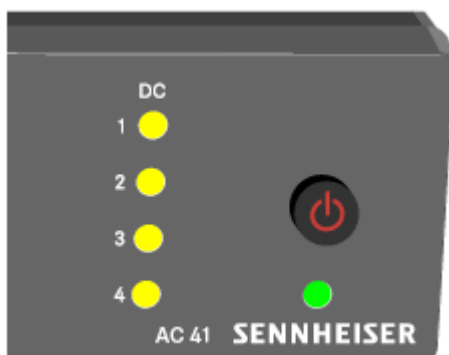

LEDs 1 to 4 are not lit:

- The transmitters are not compatible with the AC 41 antenna combiner.
 - Make sure that the transmitter has its own power supply.

OR

- There is a short circuit at the sockets RF IN 1 to RF IN 4.
 - Check the antenna connections.
 - Replace the connecting cable if needed.





Establishing a radio link

To establish a radio link between the transmitter and receiver, the same frequency must be set in both devices.

You can do this in a number of different ways:

- Use the Easy Setup function to perform an automatic frequency setup (see [Easy Setup menu item](#)).
- Set a frequency in the receiver manually [Frequency Preset menu item](#) and synchronize it with the transmitter (see [Synchronizing devices](#)).
- Set the frequency on the receiver and the transmitter manually
 - EK IEM G4: [Frequency Preset menu item](#)
 - SR IEM G4: [Frequency Preset menu item](#)

Setting notes

Please note the following when synchronizing a transmitter with a receivers:

- ▶ Only use transmitters and receivers from the same frequency range (see the type plate on the transmitter and receiver).
- ▶ Make sure that your chosen frequencies are listed in the frequency table for the particular frequency range (see [Frequency tables](#)).
- ▶ Ensure that the desired frequencies are permitted in your country and apply for an operating license if necessary.
- ▶ Please note the information at the following address: sennheiser.com/sifa.



Synchronizing devices

You can synchronize ew IEM G4 series transmitters and receivers via the transmitter's and receiver's infrared interfaces.

The Easy Setup Sync function makes it possible to transfer unused frequency presets from your EK IEM G4 receiver to multiple transmitters via the infrared interface after you have performed a frequency preset scan with this receiver. The next unused channel in the receiver's current frequency bank is transferred to your transmitter.

Vice versa, you can use the Sync function to configure the settings for your EK IEM G4 portable receiver directly on your stationary SR IEM G4 transmitter and transfer them to the receivers via the infrared interface.

Easy Setup Sync-function (EK IEM G4 -> SR IEM G4) for a single radio link

- ▶ Switch your stationary transmitter and your mobile receivers on.
- ▶ Call up the Easy Setup menu item on the transmitter.
- ▶ Choose the Mute RF For Only This Device? option.
 - ✔ The SYNC display appears in the transmitter display panel and the blue LED on the infrared interface lights up.
- ▶ Perform a frequency preset scan with your EK IEM G4 mobile receiver (see [Easy Setup menu item](#)) and select a frequency bank with sufficient unused frequencies.
- ▶ Hold the infra-red interface of the receiver in front of the infra-red interface of the first transmitter.

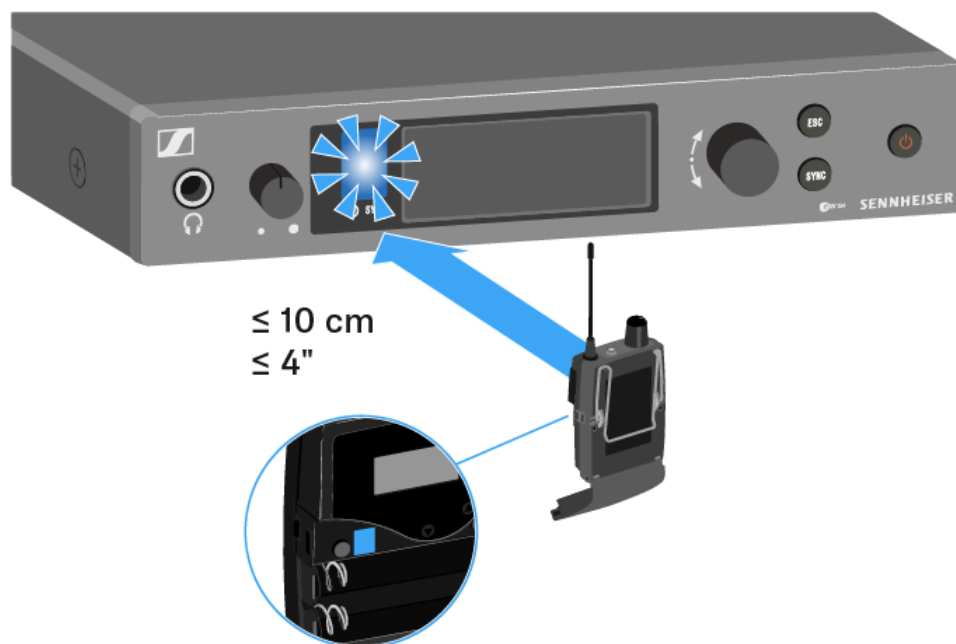

- ✓ The next unused frequency preset is transferred from the receiver to the transmitter.

Once the transfer is complete, the numbers of the transferred frequency bank and the transferred channel appear in the display panel of the transmitter.

- ▶ Press the jog dial on the transmitter to save the synchronized frequency.
- ▶ Hold the infrared interface of the mobile receiver in front of the infrared interfaces of the remaining transmitters one at a time.

Easy Setup Sync-function (EK IEM G4 -> SR IEM G4) for multi-channel frequency setup

- ▶ Perform the multi-channel frequency setup as described under [Easy Setup menu item](#).

Sync function (SR IEM G4 -> EK IEM G4)

i Die auf den Empfänger zu übertragenden **Parameter** können Sie hier einstellen: [Advanced > Sync Settings menu item](#).

- ▶ Switch the transmitter and the receiver on.
- ▶ Press the **SYNC** button on the transmitter.
- ✓ Sync appears in the transmitter's display and the blue LED turns blue.



- ▶ Hold the infra-red interface of the receiver in front of the infra-red interface of the transmitter.

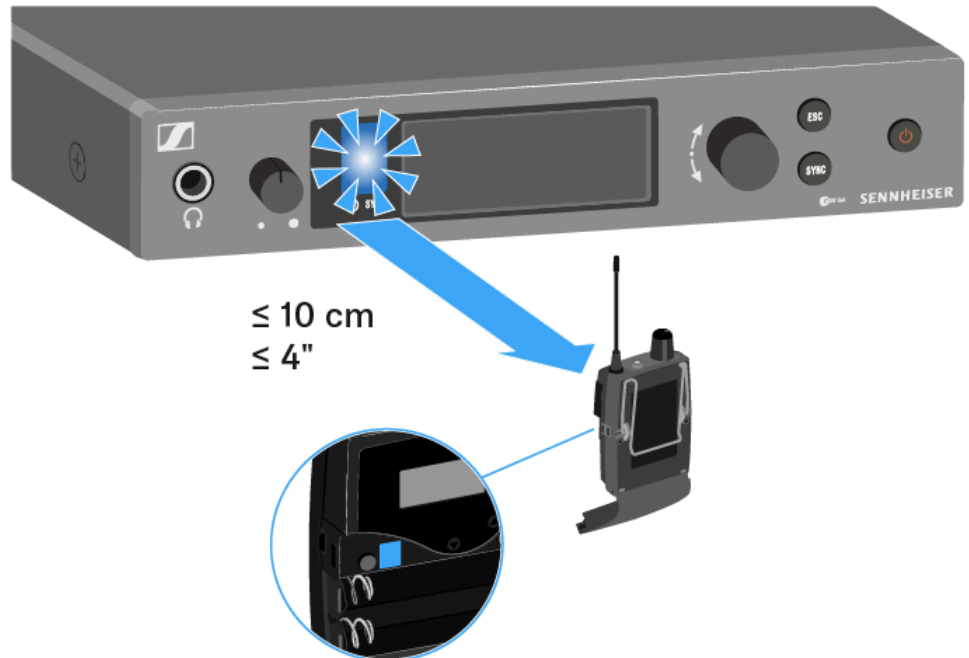

- ✓ The parameters are transferred to the receiver. The blue LED blinks during transmission.

When the transfer is complete, a tick appears in the transmitter's display as a confirmation. Then the transmitter will return to the standard display.



To cancel synchronization:

- ▶ Press the **ESC** button on the transmitter.
- ✔ An **X** appears in the display.

i This icon also appears when:

- no receiver is found or the receiver is not compatible.
- no receiver is found and the synchronization process automatically ends after 30 seconds.



Cleaning and maintenance

Note the following information when cleaning and maintaining products.

NOTICE



Liquids can damage the electronics of the product

Liquids entering the product housing can cause a short-circuit and damage the electronics.

- ▶ Keep all liquids away from the products.
- ▶ Do not use any solvents or cleansing agents.
- ▶ Disconnect the mains-operated products from the power supply system and remove rechargeable batteries and batteries (if present) before you begin cleaning.
- ▶ Clean all products only with a soft, dry cloth.



4. Specifications

All specifications at a glance.

EK IEM G4

RF characteristics

Modulation	Wideband FM
Receiving frequency ranges	A1: 470 - 516 MHz A: 516 - 558 MHz AS: 520 - 558 MHz G: 566 - 608 MHz GB: 606 - 648 MHz B: 626 - 668 MHz C: 734 - 776 MHz C-TH: 748.2 - 757.8 MHz D: 780 - 822 MHz E: 823 - 865 MHz
Receiving frequencies	Max 1680 receiving frequencies, adjustable in 25 kHz steps Max 1680 receiving frequencies, adjustable in 25 kHz steps 20 frequency banks, each with up to 16 factory-preset channels, no intermodulation 6 frequency banks with up to 16 programmable channels
Switching bandwidth	up to 42 MHz
Nominal/peak deviation	± 24 kHz / ± 48 kHz
Receiver principle	Adaptive diversity
Sensitivity (with HDX, peak deviation)	< 4 μ V, typ. 1.6 μ V for 52 dBA eff S/N
Adjacent channel selection	typ. ≥ 65 dB
Intermodulation attenuation	typ. ≥ 70 dB
Blocking	≥ 80 dB
Squelch	5 to 25 dB μ V, adjustable in 2 dB steps
Pilot tone squelch	Can be switched off



AF characteristics

Compander system	Sennheiser HDX
Signal-to-noise ratio (1 mV, peak deviation)	approx. 90 dB
Total harmonic distortion (THD)	≤ 0,9 %
Output power at 2.4 V 5% THD, nominal deviation	2 x 100 mW at 32 Ω
High Boost	+8 dB at 8 kHz
Limiter	-18 dB to -6 dB in 6 dB steps, can be switched off

Overall device

Temperature range	-10 °C to +55 °C (14 °F to 131 °F)
Power supply	2 AA batteries, 1.5 V or BA 2015 accupack
Nominal voltage	3 V battery 2.4 V rechargeable battery
Power consumption at nominal voltage with transmitter switched off	typ. 140 mA ≤ 25 μA
Operating time	approx. 4 to 6 hours (depending on the volume level)
Dimensions	approx. 82 x 64 x 24 mm
Weight (with batteries)	approx. 125 g



SR IEM G4

RF characteristics

Modulation	FM broadband stereo (MPX pilot tone procedure)
Frequency ranges	A1: 470 - 516 MHz A: 516 - 558 MHz AS: 520 - 558 MHz G: 566 - 608 MHz GB: 606 - 648 MHz B: 626 - 668 MHz C: 734 - 776 MHz C-TH: 748.2 - 757.8 MHz D: 780 - 822 MHz E: 823 - 865 MHz
Receiving frequencies	Max 1680 receiving frequencies, adjustable in 25 kHz steps 20 frequency banks, each with up to 16 factory-preset channels, no intermodulation 6 frequency banks with up to 16 programmable channels
Switching bandwidth	up to 42 MHz
Nominal/peak deviation	± 24 kHz / ± 48 kHz
MPX-Pilotton (frequency/deviation)	19 kHz / ± 5 kHz
Frequency stability	± 10 ppm
Antenna output	BNC socket, 50 Ω
RF output power at 50 Ω	Switchable; Low: typ. 10 mW Standard: typ. 30 mW High: typ. 50 mW

AF characteristics

Compander system	Sennheiser HDX
AF frequency response	25 to 15.000 Hz



AF input BAL AF IN L (I) + MONO/ BAL AF IN R (II)	2x XLR-3/ 6.3 mm jack combo socket (1/4"), electronically balanced
Max. input level	+22 dBu
Total harmonic distortion (at 1 kHz and nominal deviation)	≤ 0,9 %
Signal-to-noise ratio at rated input and peak deviation	> 90 dB
AF output LOOP OUT BAL L (I)/ LOOP OUT BAL R (II)	6.3mm stereo jack socket (1/4"), balanced

Overall device

Temperature range	-10 °C to +55 °C (14 °F to 131 °F)
Power supply	12 V DC
Power consumption	max. 350 mA
Dimensions	approx. 202 x 212 x 43 mm
Weight	approx. 980 g



AC 41

Frequency ranges	AC 41-EU/-UK: 470 - 870 MHz AC 41-US: 470 - 609 MHz
Transmission loss	0 dB (± 1 dB)
RF input power	max. 30 mW per input
Impedance	50 Ω
Power supply	13.8 V DC (with tabletop power supply unit NT 3-1)
Total power consumption	max. 3.4 A (with connected transmitters)
Transmitter power supply on RF IN 1 to RF IN 4	11.4 V DC (protected against reverse supply), 350 mA
Relative air humidity	5 to 95%
Temperature range	Operation: -10 °C to +55 °C (14 °F to 131 °F) Storage: 20°C to +70°C (-4 °F to 158 °F)
Dimensions	approx. 212 x 168 x 43 mm
Weight	approx. 1470 g
Block diagram	



IE 100 PRO earphones

Frequency response	20 – 18,000 Hz
Impedance	20 Ω
Sound pressure level	115 dB (1 kHz / 1 V rms)
Total harmonic distortion (THD)	< 0.1 % (1 kHz, 94 dB)
Noise attenuation	< 26 dB
Magnetic field strength	1.63 mT
Temperature	
Operation:	-5 °C to +50 °C (23 °F to 122 °F)
Storage:	-20 °C to +70 °C (-4 °F to 158 °F)
Relative humidity	< 95%



IE 500 PRO earphones

Frequency response	6 – 20,000 Hz
Impedance	16 Ω
Sound pressure level	126 dB (1 kHz / 1 V rms)
Total harmonic distortion (THD)	< 0.08 % (1 kHz, 94 dB)
Noise attenuation	< 26 dB
Magnetic field strength	2 mT
Temperature	
Operation:	-5 °C to +50 °C (23 °F to 122 °F)
Storage:	-20 °C to +70 °C (-4 °F to 158 °F)
Relative humidity	< 95%



IE 400 PRO earphones

Frequency response	6 – 19,000 Hz
Impedance	16 Ω
Sound pressure level	123 dB (1 kHz / 1 V rms)
Total harmonic distortion (THD)	< 0.08 % (1 kHz, 94 dB)
Noise attenuation	< 26 dB
Magnetic field strength	2 mT
Temperature	
Operation:	-5 °C to +50 °C (23 °F to 122 °F)
Storage:	-20 °C to +70 °C (-4 °F to 158 °F)
Relative humidity	< 95%



IE 4 earphones

Frequency ranges	40 – 20,000 Hz
Max. sound pressure level	118 dB SPL
Sound pressure	106 dB (1 kHz / 1 V rms)
Impedance	32 Ω
Nominal impedance	16 Ω
Cable length	1.4 m
Connector	3.5 mm stereo plug, gold-plated



Pin assignment

3.5 mm stereo jack plug

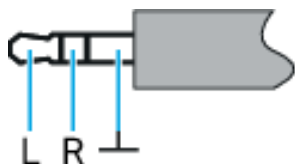

Plug for headphone and earphone cables, e. g. IE 4.

Connect to:

- EK 2000 IEM
- EK IEM G4
- XSW IEM EK

6.3 mm stereo jack plug, balanced (audio in/loop out)

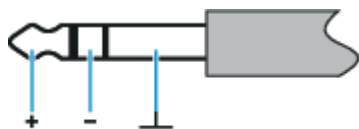

Connect to:

- SR 2000 IEM / SR 2050 IEM Audio In
- SR 2000 IEM / SR 2050 IEM Loop Out
- SR IEM G4 Audio In
- SR IEM G4 Loop Out
- XSW IEM SR Audio In
- XSW IEM SR Loop Out

6.3 mm stereo jack plug for headphone connector

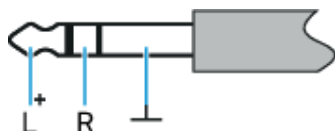

Connect to:

- SR 2000 IEM / SR 2050 IEM headphone input
- SR IEM G4 headphone input
- XSW IEM SR headphone input



XLR-3 plug, balanced

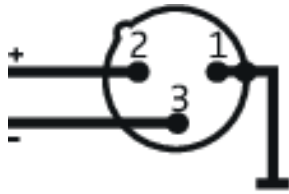

Hollow jack plug for power supply





5. Regulatory information

Information on manufacturer declarations, environmental and disposal notices, and terms of use.

Model: EM 100 G4, SKM 100 G4 | SKM 100 G4-S, SK 100 G4, EM 300-500 G4, SKM 300 G4-S, SKM 500 G4, SK 300 G4-RC, SK 500 G4, EK 100 G4, SKP 100 G4, EK 500 G4, SKP 500 G4, EK IEM G4, SR IEM G4

Conditions and restrictions for using frequencies

There may be special conditions and restrictions for using frequencies in your country.

Before putting the product into operation, find the information for your country at the following address: [sennheiser.com/sifa](https://www.sennheiser.com/sifa).

Warranty

Sennheiser electronic SE & Co. KG gives a warranty of 24 months on these products.

For the current warranty conditions, please visit our website at [sennheiser.com](https://www.sennheiser.com) or contact your Sennheiser partner.

In the US please contact:

Sennheiser Electronic Corporation

1 Enterprise Drive, Old Lyme, CT 06371

www.sennheiser.com

Warranty for Australia and New Zealand only

Sennheiser Australia Pty Ltd provides a warranty of 24 months on these products. For the current warranty conditions, visit Sennheiser website: Australia: [sennheiser.com](https://www.sennheiser.com), New Zealand: [sennheiser.com](https://www.sennheiser.com)

Sennheiser goods come with guarantees that cannot be excluded under Australian and New Zealand Consumer law. You are entitled to a replacement or refund for a major failure and compensation for any other reasonably foreseeable loss or damage. You are also entitled to have the goods repaired or replaced if the goods fail to be of acceptable quality and the failure does not amount to a major failure.

This warranty is in addition to other rights or remedies under law. Nothing in this warranty excludes, limits or modifies any remedy available to be consumer which is granted by law.

To make a claim under this contract, raise a case via Sennheiser website. Australia: [sennheiser.com/support](https://www.sennheiser.com/support), New Zealand: [sennheiser.com/support](https://www.sennheiser.com/support)

All expenses of claiming the warranty will be borne by the person making the claim.



Sennheiser international warranty is provided by: Sennheiser Australia Pty Ltd (ABN 68 165 388 312) Level 14, Tower A Zenith Building, 821 Pacific Highway, Chatswood NSW 2067, Australia

Europe



Range A1 (470 - 516 MHz), Range Aw+ (470 - 558 MHz), Range A (516 - 558 MHz), Range AS (520 - 558 MHz), Range Gw1 (558 - 608 MHz), Range Gw (558 - 626 MHz), Range G (566 - 608 MHz), Range GB (606 - 648 MHz), Range GBw (606 - 678 MHz), Range B (626 - 668 MHz), Range Bw (626 - 698 MHz), Range Cw (718 - 790 MHz), Range C (734 - 776 MHz), Range D (780 - 822 MHz), Range Dw (790 - 865 MHz), Range E (823 - 865 MHz), Range 1G8 (1785 - 1800 MHz)

In compliance with the following requirements

- Regulation (EU) 2023/988 on general product safety
- WEEE Directive (2012/19/EU)
- Regulation (EU) 2023/1542 concerning batteries and waste batteries



Italy:

Raccolta carta



Raccolta plastica



France:



FR

Carton d'emballage
+ Sac plastique PE
+ Notice d'emploi en papier



Notes on disposal

The symbol of the crossed-out dumpster on the product, the (rechargeable) battery (if applicable) and/or the packaging indicates that these products must not be disposed of with normal household waste, but must be disposed of separately at the end of their service life. For the packaging, follow the regulations in your country for separating waste. Improper disposal of packaging materials can be harmful to your health and the environment.

The separate collection of waste electrical and electronic equipment, (rechargeable) batteries (if applicable) and packaging is intended to promote reuse and recycling and to prevent



negative impacts on public health and the environment, for example due to hazardous substances contained in these products. At the end of their service life, recycle electrical and electronic equipment and (rechargeable) batteries so that their materials can be reused and to prevent environmental pollution.

If (rechargeable) batteries can be removed without destroying them, you are obliged to dispose of them separately (see the product's operating instructions for information on how to remove the batteries safely). Be especially careful when handling (rechargeable) batteries containing lithium, as these pose special hazards, such as the risk of fire and/or health risks if button cells are swallowed. Reduce battery waste as much as possible by using longer-life batteries or rechargeable batteries.

Further information on the recycling of these products can be obtained from your municipal administration, from the municipal collection points, or from your Sennheiser partner. You may also be able to return electrical or electronic equipment to your distributor, if they are legally required to do so. By disposing of your batteries properly, you are helping to protect public health and the environment.

EU Declaration of conformity

- RoHS Directive (2011/65/EU)

Hereby, Sennheiser electronic SE & Co. KG declares that the radio equipment type evolution wireless G4 is in compliance with Directive 2014/53/EU.

The full text of the EU declaration of conformity is available at the following internet address: [sennheiser.com/download](https://www.sennheiser.com/download).

United Kingdom



Range A1 (470 - 516 MHz), Range Aw+ (470 - 558 MHz), Range A (516 - 558 MHz), Range AS (520 - 558 MHz), Range Gw1 (558 - 608 MHz), Range Gw (558 - 626 MHz), Range G (566 - 608 MHz), Range GB (606 - 648 MHz), Range GBw (606 - 678 MHz), Range B (626 - 668 MHz), Range Bw (626 - 698 MHz), Range Cw (718 - 790 MHz), Range C (734 - 776 MHz), Range D (780 - 822 MHz), Range Dw (790 - 865 MHz), Range E (823 - 865 MHz), Range 1G8 (1785 - 1800 MHz)

In compliance with the following requirements

- WEEE Regulations (2013)
- Battery Regulations (2015)





UK Declaration of conformity

- RoHS Regulations (2012)
- Radio Equipment Regulations (2017)

Importer: Sennheiser UK Ltd.

Pacific House, Third Avenue, Globe Park, Marlow

Buckinghamshire SL7 1EY, United Kingdom

USA



Statements regarding FCC and ISED

This device complies with part 15 of the FCC rules and RSS-210 of Innovation, Science and Economic Development Canada (ISED). Operation is subject to the following two conditions: (1) this device may not cause harmful interference, and (2) this device must accept any interference received, including interference that may cause undesired operation.

This Class B digital device complies with the Canadian ICES-003.

Changes or modifications not expressly approved by Sennheiser electronic Corp. could void the user's authority to operate the equipment.

Contact information: Sennheiser Electronic Corporation, 1 Enterprise Drive, Old Lyme, CT 06371; sennheiser.com

Caution:

You are cautioned that any changes or modifications not expressly approved in the instruction manual could void your authority to operate this equipment. Wireless microphone users shall rely on the white space databases in part 15 to determine that their intended operating frequencies are available for unlicensed wireless microphone operation at the location where they will be used. Wireless microphone users must register with and check a white space database to determine available channels prior to beginning operation at a given location. A user must re-check the database for available channels if it moves to another location.

Radiofrequency radiation exposure Information

This equipment complies with FCC and ISED radiation exposure limits set forth for an uncontrolled environment. The SR IEM G4 should be installed and operated with a minimum distance of 20 cm between the radiator and your body.

SK / SKM / SKP: The radiated output power of the device is far below the FCC and ISED radio frequency exposure limits. Nevertheless, the device shall be used in such a manner that the potential for human contact during normal operation is minimized.

RSS-Gen Issue 5 - 6.8 Transmit antenna



This radio transmitter [IC: 2099A-G4SR] has been approved by Innovation, Science and Economic Development Canada to operate with the antenna types listed below, with the maximum permissible gain indicated. Antenna types not included in this list that have a gain greater than the maximum gain indicated for any type listed are strictly prohibited for use with this device.

Omni Antenna: +1.75 dBi, 50 Ω

RSS-210 Issue 10 Annex G.6

This device operates on a no-interference, no-protection basis. Should the user seek to obtain protection from other radio services operating in the same TV bands, a radio licence is required. For further details, consult Innovation, Science and Economic Development Canada's Client Procedures Circular CPC-2-1-28, Voluntary Licensing of Licence-Exempt Wireless Microphones in the TV Bands.

Range A1 (470 - 516 MHz), Range A (516 - 558 MHz), Range AS (520 - 558 MHz), Range G (566 - 608 MHz)

SKM FCC ID: DMOSKM1574

SK FCC ID: DMOSK1574

SKP FCC ID: DMOG4SKP

SR FCC ID: DMOG4SR

Range Aw+ (470 - 558 MHz), Range Gw1 (558 - 608 MHz)

SKM FCC ID: DMOSKM1574

SK FCC ID: DMOSK1574

SKP FCC ID: DMOG4SKP

Canada

Statements regarding FCC and ISED

This device complies with part 15 of the FCC rules and RSS-210 of Innovation, Science and Economic Development Canada (ISED). Operation is subject to the following two conditions: (1) this device may not cause harmful interference, and (2) this device must accept any interference received, including interference that may cause undesired operation.

This Class B digital device complies with the Canadian ICES-003.

Changes or modifications not expressly approved by Sennheiser electronic Corp. could void the user's authority to operate the equipment.

Radiofrequency radiation exposure Information

This equipment complies with FCC and ISED radiation exposure limits set forth for an uncontrolled environment. The SR IEM G4 should be installed and operated with a minimum distance of 20 cm between the radiator and your body.



SK / SKM / SKP: The radiated output power of the device is far below the FCC and ISED radio frequency exposure limits. Nevertheless, the device shall be used in such a manner that the potential for human contact during normal operation is minimized.

RSS-Gen Issue 5 - 6.8 Transmit antenna

This radio transmitter [IC: 2099A-G4SR] has been approved by Innovation, Science and Economic Development Canada to operate with the antenna types listed below, with the maximum permissible gain indicated. Antenna types not included in this list that have a gain greater than the maximum gain indicated for any type listed are strictly prohibited for use with this device.

Omni Antenna: +1.75 dBi, 50 Ω

RSS-210 Issue 10 Annex G.6

This device operates on a no-interference, no-protection basis. Should the user seek to obtain protection from other radio services operating in the same TV bands, a radio licence is required. For further details, consult Innovation, Science and Economic Development Canada's Client Procedures Circular CPC-2-1-28, Voluntary Licensing of Licence-Exempt Wireless Microphones in the TV Bands.

Range A1 (470 - 516 MHz), Range A (516 - 558 MHz), Range AS (520 - 558 MHz), Range G (566 - 608 MHz)

SKM IC: 2099A-SKM1574

SK IC: 2099A-SK1574

SKP IC: 2099A-G4SKP

SR IC: 2099A-G4SR

Range Aw+ (470 - 558 MHz), Range Gw1 (558 - 608 MHz)

SKM IC: 2099A-SKM1574

SK IC: 2099A-SK1574

SKP IC: 2099A-G4SKP

Australia



Range AS (520 - 558 MHz), Range Gw1 (558 - 608 MHz), Range Gw (558 - 626 MHz), Range GB (606 - 648 MHz), Range GBw (606 - 678 MHz), Range B (626 - 668 MHz), Range 1G8 (1785 - 1800 MHz)

Range Bw (626 - 698 MHz) limited to 694 MHz



New Zealand



Range AS (520 - 558 MHz), Range B (626 - 668 MHz), Range Bw (626 - 698 MHz)

Range Gw1 (558 - 608 MHz) limited to 606 MHz

Range GB (606 - 648 MHz), Range GBw (606 - 678 MHz) starting at 622 MHz

Japan

Range JB (806 - 810 MHz)



SKM: R 202-SMF086

SK: R 202-SMF085

SKP: R 202-SMF087

Brazil

Este equipamento não tem direito à proteção contra interferência prejudicial e não pode causar interferência em sistemas devidamente autorizados.

Para maiores informações, consulte o site da ANATEL

www.gov.br/anatel/pt-br

Range A1 (470 - 516 MHz), Range A (516 - 558 MHz), Range AS (520 - 558 MHz), Range G (566 - 608 MHz), Range B (626 - 668 MHz), Range Bw (626 - 698 MHz)



SK 07061-18-07356

SKM 00325-19-07356

SKP 00330-19-07356

SR 00703-19-07356

Range Aw+ (470 - 558 MHz), Range Gw1 (558 - 608 MHz)





SK 07061-18-07356

SKM 00325-19-07356

SKP 00330-19-07356

India

Range A1 (470 - 516 MHz), Range Aw+ (470 - 558 MHz), Range A (516 - 558 MHz), Range Gw (558 - 626 MHz), Range G (566 - 608 MHz), Range B (626 - 668 MHz), Range Bw (626 - 698 MHz), Range Cw (718 - 790 MHz), Range C (734 - 776 MHz)

SK, SKM, SKP

IS 616/IEC 60065



R-41196606
www.bis.gov.in

South Korea



Range Aw30 (470 - 558 MHz), Range Bw30 (626 - 698 MHz)

기기의 명칭: True Diversity Receiver

- 모델명: EM 300-500 G4 인증번호: R-R-SE9-EMG4-Aw30

기기의 명칭: 특정소출력 무선기기 (음성 및 음향신호 전 송용 무선기기)

- 모델명 SK 300 G4 인증번호: R-C-SE9-SK300G4-Aw30
- 모델명: SKM 300 G4 인증번호: R-C-SE9-SKM300G4-Aw30

기기의 명칭: 특정소출력 무선기기 (음성 및 음향신호 전 송용 무선기기)

- 모델명 SK 100 G4 인증번호: MSIP-CRM-SE9-SK100G3-A
- 모델명: SKM 100 G4 & SKM 100-S G4 인증번호: MSIP-CRM-SE9-SKM100G3-A
- 모델명: SKP 100 G4 인증번호: R-C-SE9-SKP100G4-A

Range A (516 - 558 MHz), Range B (626 - 668 MHz)

기기의 명칭: True Diversity Receiver

- 모델명: EM 100 G4 인증번호: R-R-SE9-EM100G4-A



기기의 명칭: Diversity Receiver

- 모델명: EK 100 G4 인증번호: MSIP-REM-SE9-EK100G3-A

Range A30 (516 - 558 MHz), Range B30 (626 - 668 MHz)

기기의 명칭: Diversity Receiver

- 모델명: EK IEM G4 인증번호: R-R-SE9-EKIEMG4-A30

기기의 명칭: 특정소출력 무선기기 (음성 및 음향신호 전 송용 무선기기)

- 모델명 SR IEM G4 인증번호: R-C-SE9-SRIEMG4-A30

Range K+ (925 - 937.5 MHz)

기기의 명칭: Diversity Receiver

- 모델명: EK 100 G4 인증번호: MSIP-REM-SE9-EK100G3
- 모델명: EK 500 G4 인증번호: R-REM-SE9-EK500G4

기기의 명칭: True Diversity Receiver

- 모델명: EM 100 G4 인증번호: MSIP-REM-SE9-EM100G3
- 모델명: EM 300-500 G4 인증번호: MSIP-REM-SE9-EM500G3

기기의 명칭: 특정소출력 무선기기 (음성 및 음향신호 전 송용 무선기기)

- 모델명: SK 100 G4 인증번호: MSIP-CRM-SE9-SK100G3
- 모델명 SK 300 G4 인증번호: MSIP-CRM-SE9-SK100G3
- 모델명: SK 500 G4 인증번호: MSIP-CRM-SE9-SK100G3
- 모델명: SKM 100 G4 인증번호: MSIP-CRM-SE9-SKM300G3
- 모델명: SKM 100 S G4 인증번호: MSIP-CRM-SE9-SKM300G3
- 모델명: SKM 300 G4 인증번호: MSIP-CRM-SE9-SKM300G3
- 모델명: SKM 500 G4 인증번호: MSIP-CRM-SE9-SKM300G3
- 모델명: SKP 500 G4 인증번호: R-CRM-SE9-SKP500G4
- 모델명: SKP 100 G4 인증번호: R-CRM-SE9-SKP500G4

상호:

Sennheiser electronic SE & Co. KG 제조년월일: 2018 제조자/제조국: Sennheiser electronic SE & Co. KG / 독일

Vietnam

Кể từ ngày 1 tháng 12 năm 2012, các sản phẩm được sản xuất bởi Sennheiser tuân thủ Thông tư 30/2011/TT-BCT quy định về giới hạn cho phép đối với một số chất độc hại trong các sản phẩm điện và điện tử.



Thailand

Range C-TH (748.2 - 757.8 MHz), Range Cw-TH (748.2 - 757.8 MHz)



ผู้ใดมีไว้ในครอบครอง หรือ ใช้ซึ่งเครื่องวิทยุคมนาคมหรือตั้งสถานีวิทยุคมนาคมนี้ ต้องได้รับใบอนุญาตจากเจ้าพนักงานผู้ออกใบอนุญาต หากฝ่าฝืน มาตรา 6 หรือมาตรา 11 มีความผิดตามมาตรา 23 แห่งพระราชบัญญัติวิทยุคมนาคม พ.ศ. 2498 ต้องระวางโทษปรับไม่เกินหนึ่งแสนบาท หรือจำคุกไม่เกินห้าปี หรือทั้งปรับทั้งจำ

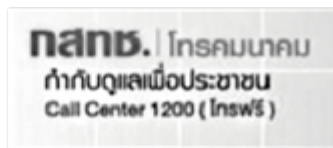

Singapore

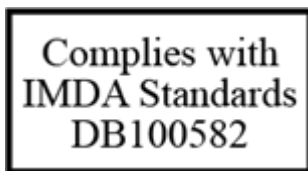

Range Aw+ (470 - 558 MHz), Range Gw1 (558 - 608 MHz), Range Gw (558 - 626 MHz), Range GB (606 - 648 MHz), Range Bw (626 - 698 MHz) max. RF Power 10 mW

Range A10 (516 - 558 MHz), Range B10 (626 - 668 MHz)

China

使用微功率短距离无线电发射设备应当符合国家无线电管理有关规定

(一) 符合“微功率短距离无线电发射设备目录和技术要求”的具体条款和使用场景，

采用的天线类型和性能，控制、调整及开关等使用方法：

具体条款

无线传声器

用于教育、文化部门的视听训练，电影院、音乐厅、会议室等公共

场所及残疾



人士的听觉辅助使用。在旅游区作为小型广播设备应用。

若使用频率与当地声音、电视广播电台频率相同时，不得在当地使用；若对

当地声音、电视广播接收产生干扰时，应立即停止使用，待消除干扰或调整

到无干扰频率后方可重新使用。

1·使用频率及发射功率：

(1) 使用频率：87-108MHz

发射功率限值：

45nW(e.r.p)，手机附带无线传声器；

3mW(e.r.p)，其他设备。

(2) 使用频率：75.4-76MHz, 84-87MHz, 189.9-223MHz

发射功率限值：10mW(e.r.p)

(3) 使用频率：470-510MHz, 630-698MHz

发射功率限值：50mW(e.r.p)

2·占用带宽：不大于200kHz

3·频率容限：100×10⁻⁶

使用场景：音乐舞台、演讲台、剧院、会议

天线的类型：单极天线

性能/控制：无线电范围100米

调整及开关产品的使用方法：通过接收器的用户界面

(二) 不得擅自改变使用场景或使用条件、扩大发射频率范围、加大发射功率（包括额外加装射频功率放大器），不得擅自更改发射天线；

(三) 不得对其他合法的无线电台（站）产生有害干扰，也不得提出免受有害干扰保护；

(四) 应当承受辐射射频能量的工业、科学及医疗（ISM）应用设备的干扰或其他合法的无线电台（站）干扰；

(五) 如对其他合法的无线电台（站）产生有害干扰时，应立即停止使用，并采取有效措施消除干扰后方可继续使用；

(六) 在航空器内和依据法律法规、国家有关规定、标准划设的射电天文台、气象雷达

站、卫星地球站（含测控、测距、接收、导航站）等军民用无线电台（站）、机场等的

电磁环境保护区域内使用微功率设备，应当遵守电磁环境保护及相关行业主管部门的规定；



(七) 禁止在以机场跑道中心点为圆心、半径5000 米的区域内使用各类模型遥控器；

(八) 微功率设备使用时温度和电压的环境条件

-10°C-+ 55°C的工作温度，2个1.5V AA电池，并随附机架式接收器的电源。

China RoHS

部件名称 (Parts)	有害物质										产品环保年限 EFUP
	铅 (Pb)	汞 (Hg)	镉 (Cd)	六价铬 (Cr6+)	多溴联苯 (PBB)	多溴二苯醚 (PBDE)	邻苯二甲酸二 (2-乙基己)酯 (DEHP)	邻苯二甲 酸丁基酯 (BBP)	邻苯二甲 酸二丁酯 (DBP)	邻苯二甲 酸二异丁酯 (DIBP)	
金属部件 (Metal parts)	x	o	o	o	o	o	o	o	o	o	15
电路模块 (Circuit Modules)	x	o	o	o	o	o	o	o	o	o	15
电缆及电缆组件 (Cables & Cable Assemblies)	x	o	o	o	o	o	o	o	o	o	15
外部电力适配器 - 如果包含 (external power supply - if available)	x	o	o	o	o	o	o	o	o	o	10

本表格依据 SJ/T 11364 的规定编制。
 o: 表示该有害物质在该部件所有均质材料中的含量均在 GB/T 26572 规定的限量要求以下。
 x: 表示该有害物质至少在该部件的某一均质材料中的含量超出 GB/T 26572 规定的限量要求。

