



## 2000 IEM Series

Wireless monitoring system

PDF Export of the Original HTML Manual



# Contents

1. Preface.....	4
2. Product Information.....	5
Products of the 2000 IEM series.....	5
Stereo diversity receiver EK 2000 IEM.....	5
2-channel/stereo monitoring transmitter SR 2000 IEM.....	7
2-channel/stereo monitoring transmitter SR 2050 IEM.....	8
Antenna Combiner AC 3200-II.....	9
Accessories.....	10
Earphones.....	10
Rechargeable battery and charger.....	13
Antennas and accessories.....	14
The frequency bank system.....	17
Frequency tables.....	18
3. User Manual.....	19
Stereo diversity receiver EK 2000 IEM.....	19
Product overview.....	19
Inserting and removing the batteries/rechargeable batteries.....	21
Connecting earphones to the EK 2000 IEM.....	22
Attaching the diversity receiver to your clothing.....	23
Switching the receiver on and off.....	25
Lock-off function.....	26
Displays on the EK 2000 IEM display panel.....	27
Home Screen.....	28
Battery status.....	32
Buttons for navigating through the menu.....	33
Menu structure.....	35
Setting options in the menu.....	36
Stereo transmitter SR 2000 IEM   SR 2050 IEM.....	60
Product overview.....	60
Connecting/disconnecting the transmitter with/from the power supply.....	62
Creating a data network.....	64
Connecting audio signals.....	65
Daisy chaining audio signals.....	67
Connecting antennas.....	68
Mounting the transmitter into a rack.....	71



Switching the transmitter on and off.....	72
Using the headphone output.....	73
Configuring the audio channels (mono/stereo).....	74
Deactivating the RF signal (RF mute).....	75
Lock-off function.....	77
Displays on the transmitter display panel.....	78
Buttons for navigating the transmitter menu.....	80
Setting options in the menu.....	81
Antenna Combiner AC 3200-II.....	97
Product overview.....	97
Connecting/disconnecting the AC 3200-II to/from the power supply system.....	99
Connecting the AC 3200-II with transmitters.....	100
Connecting antennas.....	101
Installing the AC 3200-II in a rack.....	102
Switching the AC 3200-II on and off.....	103
RF indicators.....	104
Recommendations and tips for optimum transmission.....	105
Establishing a radio link.....	106
Synchronizing devices.....	107
Cleaning and maintenance.....	110
4. Specifications.....	111
EK 2000 IEM.....	111
SR 2000 IEM   SR 2050.....	113
AC 3200-II.....	115
IE 500 PRO earphones.....	116
IE 400 PRO earphones.....	117
IE 4 earphones.....	118
Pin assignment.....	119
5. Regulatory Information.....	121



# 1. Preface

## **PDF Export of the Original HTML Manual**

This PDF document is an automatic export of an interactive set of HTML manuals. Some content and interactive elements may not be included in the PDF because they cannot be displayed in this format. In addition, automatically generated page breaks may cause related content to be slightly shifted. We can therefore only guarantee the completeness of the information in the HTML manual and recommend using it. You can find it in the Documentation Portal at [www.sennheiser.com/documentation](http://www.sennheiser.com/documentation).



## 2. Product Information

Information about the products of the 2000 IEM series.

### Products of the 2000 IEM series

#### Stereo diversity receiver EK 2000 IEM



Lightweight, robust bodypack transmitter. AF frequency response optimized for bass guitar. Up to 6 x 64 user-programmable channels. Easy receiver-transmitter synchronization at the push of a button. All-metal housing.

**EK 2000 IEM-Aw+** | 470 - 558 MHz | Art. no. 508641

**EK 2000 IEM-Gw** | 558 - 626 MHz | Art. no. 503863

**EK 2000 IEM-Gw1** | 558 - 608 MHz | Art. no. 608627

**EK 2000 IEM-GBw** | 606 - 678 MHz | Art. no. 504947

**EK 2000 IEM-Bw** | 626 - 698 MHz | Art. no. 503865



**i** You can find more detailed information about the EK 2000 IEM in the following sections:

- **Startup and operation:** [Stereo diversity receiver EK 2000 IEM](#)
- **Specifications:** [EK 2000 IEM](#)



## 2-channel/stereo monitoring transmitter SR 2000 IEM



Rugged, reliable, and flexible - in short: professional. With SR 2000, you can choose from 26 frequency banks with up to 32 channels. The channels can be user-programmed six of the frequency banks. Three switchable RF output powers (10, 30, and 50 mW - additionally 100 mW in the US version) provide greatest artistic and technical freedom.

**i** You can find more detailed information about the SR 2000 IEM in the following sections:

- **Startup and operation:** [Stereo transmitter SR 2000 IEM | SR 2050 IEM](#)
- **Specifications:** [SR 2000 IEM | SR 2050](#)



## 2-channel/stereo monitoring transmitter SR 2050 IEM



Robust 19"-rack twin transmitter for wireless monitoring. Up to 6 x 32 tunable channels. Switchable HF output power. Remote-controllable via Wireless Systems Manager ([sennheiser.com/wsm](https://sennheiser.com/wsm)).

**SR 2050XP IEM Aw+** | 470 - 558 MHz | Art. no. 508636

**SR 2050 IEM Aw+** | 470 - 558 MHz | Art. no. 508644

**SR 2050 IEM Gw** | 558 - 626 MHz | Art. no. 503847

**SR 2050XP IEM Gw** | 558 - 626 MHz | Art. no. 504058

**SR 2050XP IEM Gw1** | 558 - 608 MHz | Art. no. 508626

**SR 2050 IEM GBw** | 606 - 678 MHz | Art. no. 504955

**SR 2050 IEM Bw** | 626 - 698 MHz | Art. no. 503851

**SR 2050XP IEM Bw** | 626 - 698 MHz | Art. no. 504059

**i** You can find more detailed information about the SR 2050 IEM in the following sections:

- **Startup and operation:** [Stereo transmitter SR 2000 IEM | SR 2050 IEM](#)
- **Specifications:** [SR 2000 IEM | SR 2050](#)



## Antenna Combiner AC 3200-II



Active 8-channel antenna combiner for large, wireless monitor systems. Up to eight inputs, up to 100 mW per channel, for transmission via single antenna. Avoids bothersome intermodulation; quick overview via LED strip.

Art. no. 505497

**i** You can find more detailed information about the AC 3200-II in the following sections:

- **Startup and operation:** [Antenna Combiner AC 3200-II](#)
- **Specifications:** [AC 3200-II](#)



## Accessories

A variety of accessories are available for the 2000 series.

### Earphones

#### IE 400 PRO

IE 400 PRO SMOKY BLACK | Article no. 507483



IE 400 PRO CLEAR | Article no. 507484



**i** Specifications: [IE 400 PRO earphones](#)



## IE 500 PRO

IE 500 PRO SMOKY BLACK | Article no. 507479



IE 500 PRO CLEAR | Article no. 507480



**i** Specifications: [IE 500 PRO earphones](#)

## IE 4

IE 4 | Article no. 500432



**i** Specifications: [IE 4 earphones](#)



## Rechargeable battery and charger

### BA 2015 rechargeable battery

The BA 2015 rechargeable battery is designed for use with 2000 IEM series handheld transmitters, bodypack transmitters and bodypack receivers.

Art. no. 009950



### L 2015 charger

The BA 2015 rechargeable battery can be charged in the L 2015 charger on its own or inside of the bodypack transmitter/bodypack receiver.

Art. no. 009828





## Antennas and accessories

### Antenna mount GA 3030 AM

Permits the connection of EM 3031, EM 3032, EM 3532, SR 3054 and SR 3056 antennæ to the front of the rack.

Art. no. 004368



### Passive antenna A 5000-CP

The A 5000-CP passive antenna provides an optimum solution for both transmitting and receiving RF signals throughout the UHF spectrum. Installations have demonstrated that the circular polarization of this antenna minimizes variations in signal strength and almost eliminates multipath problems, a primary cause dropouts. The gain of this antenna over the entire UHF band is superior to common 'off the shelf' antennas.

The wideband design (450-960MHz) of the A 5000-CP allows it to accommodate antenna distribution systems for either wireless monitors or wireless microphones across multiple frequency ranges, offering maximum flexibility when designing complex RF systems.

Art. no. 500887



**Passive omni-directional antenna A 1031-U**

Passive omni-directional antenna. Transmitting and receiving antenna for frequencies between 450 and 960 MHz.

Art. no. 004645





## The frequency bank system

There are different frequency ranges in the UHF band available for transmission. The following frequency ranges are available for the 2000 series:

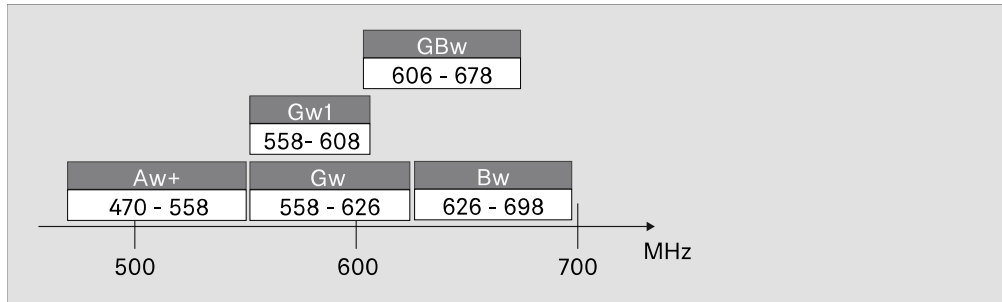

Every frequency range has 26 frequency banks with up to 32 channels:

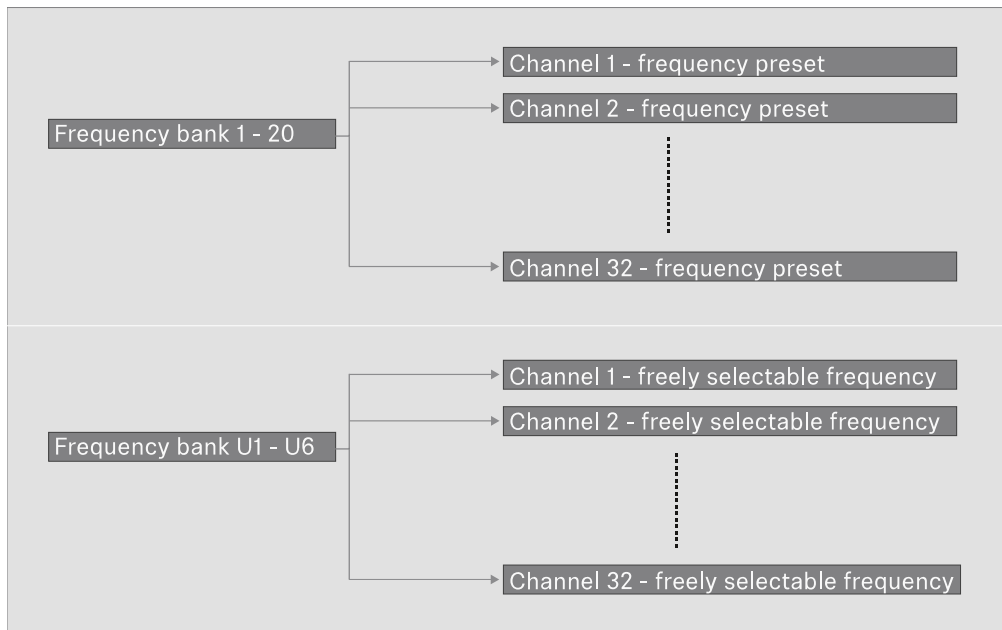



## Frequency tables

Frequency tables with the factory presets for all available frequency ranges can be found in the download area of the Sennheiser website at: [sennheiser.com/download](https://www.sennheiser.com/download).

Enter **SR 2000 IEM / SR 2050 IEM** in the search bar to show the frequency tables.



### 3. User Manual

Starting up and operating devices of the 2000 IEM series.

## Stereo diversity receiver EK 2000 IEM

### Product overview

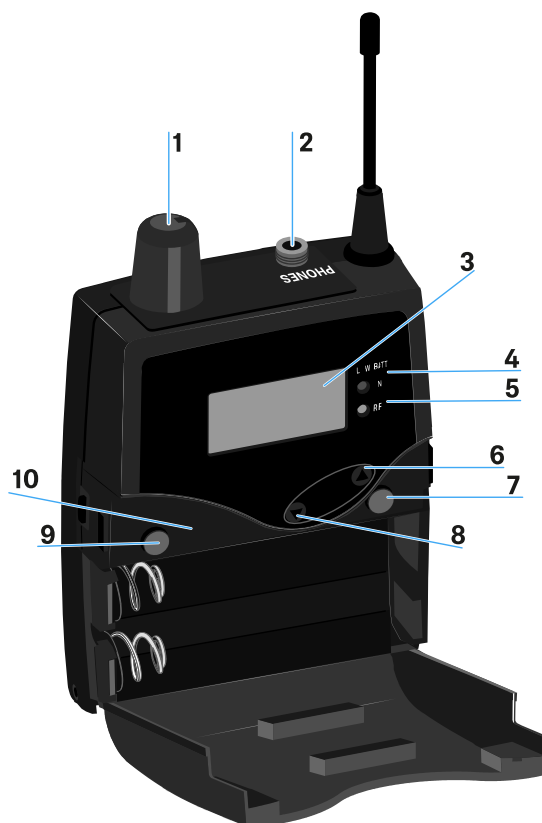

- 1 Volume control with on/off switch  
see [Connecting earphones to the EK 2000 IEM](#)  
switch the receiver on/off, see [Switching the receiver on and off](#)
- 2 3.5 mm **PHONES** jack socket, lockable  
jack for connecting an earphone  
see [Connecting earphones to the EK 2000 IEM](#)
- 3 Display panel  
see [Displays on the EK 2000 IEM display panel](#)



**4** Operation and battery indicator, red LED

illuminated = ON, see [Switching the receiver on and off](#)

flashing = LOW BATTERY, see [Rechargeable battery and charger](#) oder [Battery status](#)

**5** Wireless reception indicator, green LED

illuminated = RF, see [Squelch menu item](#)

**6** UP button

see [Buttons for navigating through the menu](#)

**7** SET button

see [Buttons for navigating through the menu](#)

**8** DOWN button

see [Buttons for navigating through the menu](#)

**9** ESC button

see [Buttons for navigating through the menu](#)

**10** Infra-red interface

see [Synchronizing devices](#)



## Inserting and removing the batteries/rechargeable batteries

You can operate the diversity receiver either with batteries (AA, 1.5 V) or with the rechargeable Sennheiser BA 2015 battery.

- ▶ Press the two catches and open the battery compartment cover.
- ▶ Insert the batteries or the rechargeable battery as shown below.
- ▶ Please observe correct polarity when inserting the batteries.

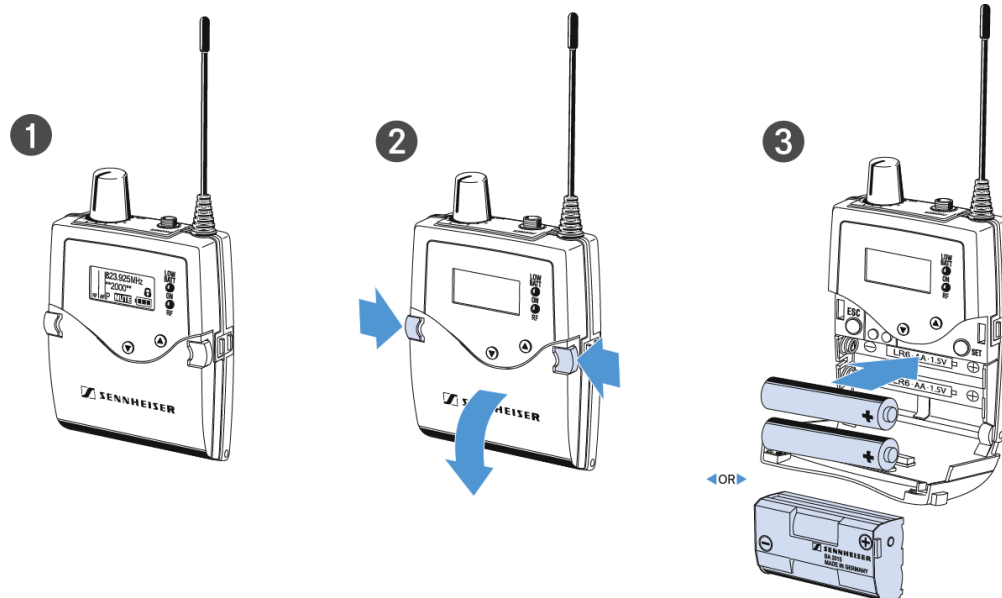

- ▶ Close the battery compartment.
  - ✓ The cover locks into place with an audible click.



## Connecting earphones to the EK 2000 IEM

### WARNING



#### Danger due to high volume levels

Volume levels that are too high may damage your hearing.

- ▶ Turn down the volume of the headphone output before you put on the headphone.

### To connect the earphones to the receiver:

- ▶ Insert the cable's 3.5 mm jack plug into the **PHONES** socket on the receiver as shown in the diagram.

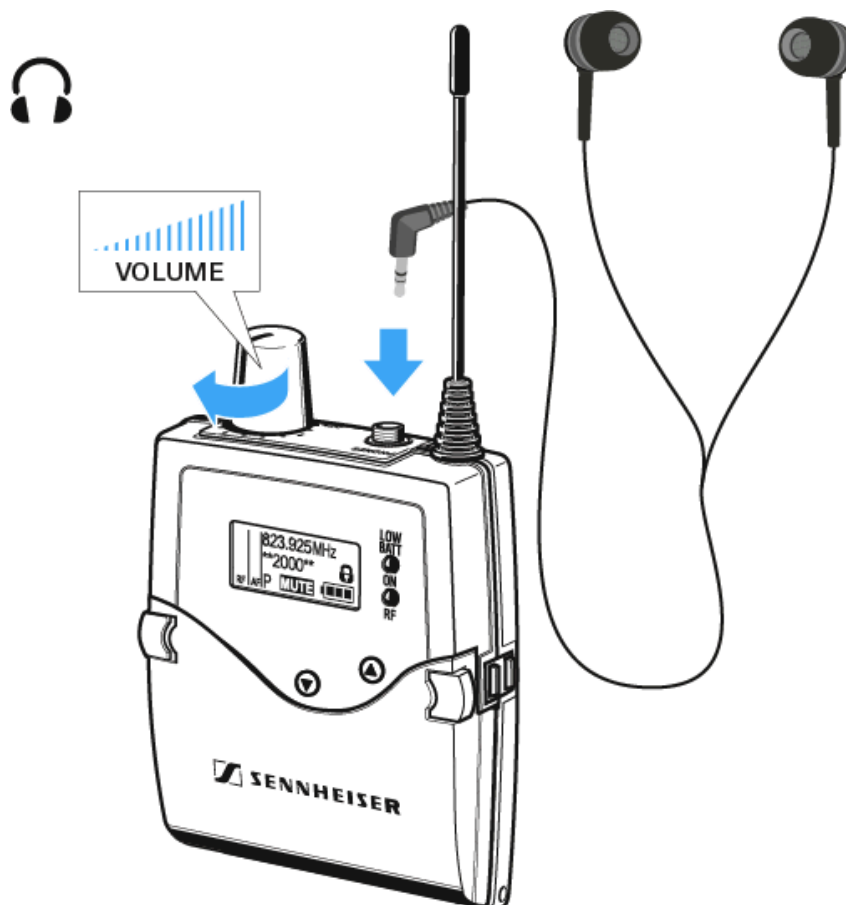

- i** The ground connection of the earphone cable acts as an antenna for the second diversity branch.



## Attaching the diversity receiver to your clothing

You can use the belt clip to attach the diversity receiver to your waistband or on a guitar strap.

The belt clip is detachable so that you can also attach the diversity receiver with the antenna pointing downwards. To do so, withdraw the belt clip from its fixing points and attach it the other way round.



The belt clip is secured so that it cannot slide out of its fixing points accidentally.

### To detach the belt clip:

- ▶ Lift the belt clip as shown in the diagram.
- ▶ Press one side of the clip downward on the fixing hole and pull it out of the housing.



- ▶ Do the same thing on the other side.

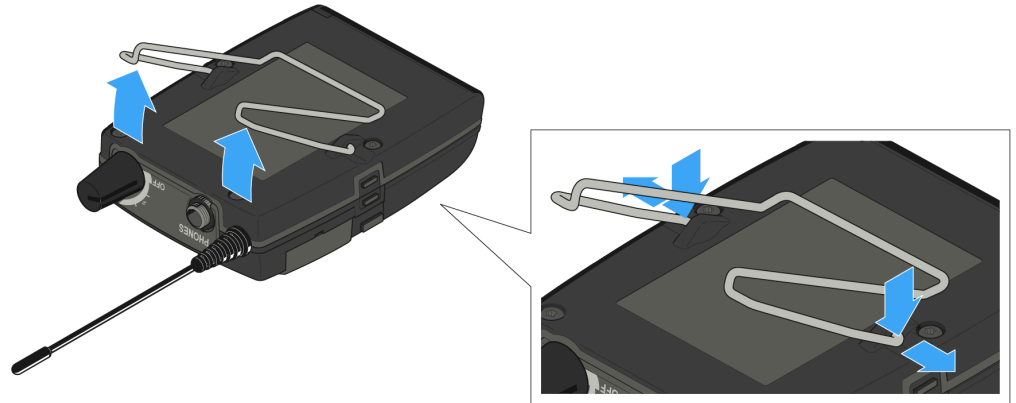



## Switching the receiver on and off

### To switch the receiver on:

- ▶ Turn the volume control clockwise until it clicks.



- ✓ The red **ON** LED is illuminated and the **Frequency/Name** standard display appears.

### To switch the receiver off:

- ▶ Turn the volume control counterclockwise until it clicks.
- ✓ The red **ON** LED will go out.



## Lock-off function

You can set the automatic lock-off function in the **Auto Lock** (see [Auto Lock menu item](#)).

When you have switched on the lock-off function, you will have to turn the receiver off and on again in order to operate it.

### To temporarily deactivate the lock-off function:

- ▶ Press the **SET** button.
  - ✓ LOCKED appears in the display panel.
- ▶ Press the **UP** or **DOWN** button.
  - ✓ UNLOCK? appears in the display panel.
- ▶ Press the **SET** button.

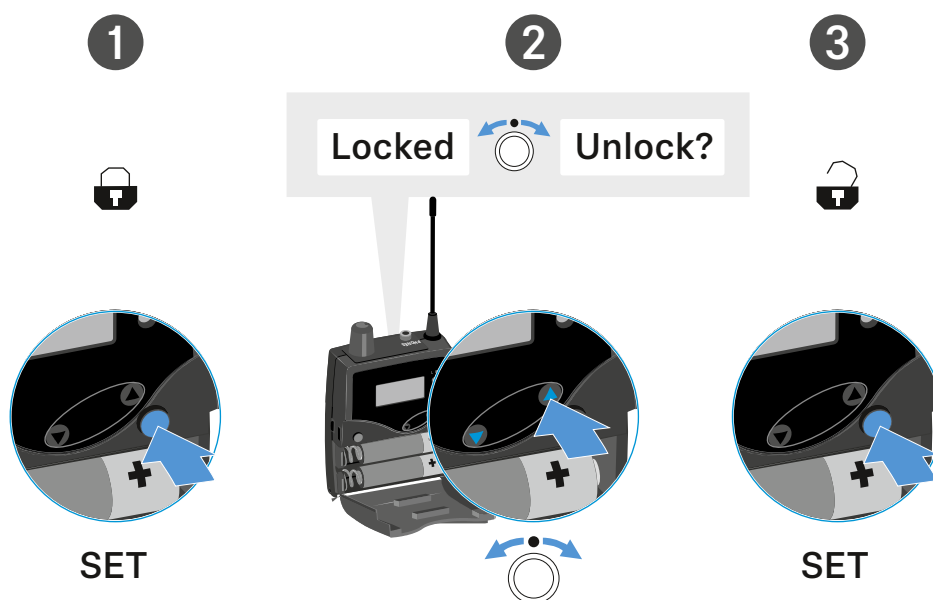

- ✓ Lock-off function is now temporarily deactivated.

### When you are in the operating menu

- Lock-off function is deactivated long enough for you to work in the operating menu.

### When one of the standard displays is shown

- Lock-off function is automatically activated after 10 seconds.

The lock-off function icon flashes while the lock-off function is activated again.



## Displays on the EK 2000 IEM display panel

Status information such as reception quality, battery status, audio level, etc. is displayed on the home screen of the display panel.

The display panel also displays the operating menu, which you can use to configure all of the settings.



## Home Screen

After you switch on the receiver, the display panel initially displays the Sennheiser logo. After a short time, the home screen is then displayed.

The home screen has three different standard displays.

On the home screen, press the **ESC** button to switch between the standard displays. In Stereo mode, you can also press the **UP/DOWN** button to switch between the standard displays.

### Frequency/Name standard display

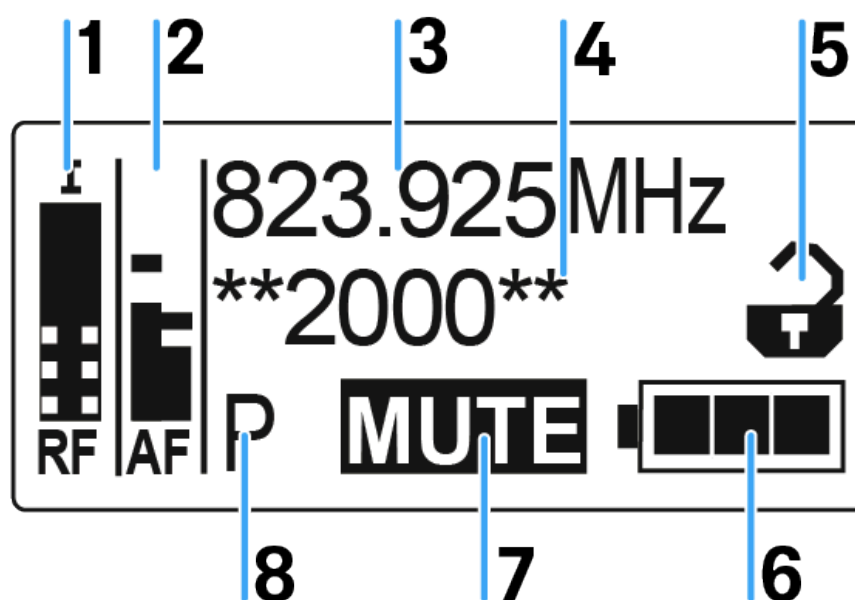

#### 1 RF level (radio frequency)

RF signal level display

including the display of the squelch threshold (see [Menüpunkt Squelch](#))

#### 2 AF audio level (audio frequency)

Displays the audio level of the received transmitter (separated by channel in Stereo mode). When the display shows full deflection, the audio input level is excessively high.

see [Balance menu item](#)

#### 3 Frequency

Current receiving frequency

see [Frequency Preset menu item](#)



**4 Name**

Freely selectable name of the receiver

see [Name menu item](#)

**5 Lock-off function**

Lock-off function is activated

see [Lock-off function](#)

**6 Battery status**

see [Rechargeable battery and charger](#)

**7 MUTE** muting function

The transmitter's RF signal is deactivated, see [Deactivating the RF signal \(RF mute\)](#)

or the transmitter is in Mono mode, see [Mode menu item](#)

**8 P** pilot ton

P = Activated pilot tone evaluation

No symbol = Evaluation is deactivated

P is black = pilot tone is atng received on the current frequency

see [Advanced -> Pilot Tone menu item](#)

**Bank/Frequency/Limiter standard display**

The Bank/Frequency/Limiter standard display also shows the audio channel (Stereo/Focus) and the limiter.

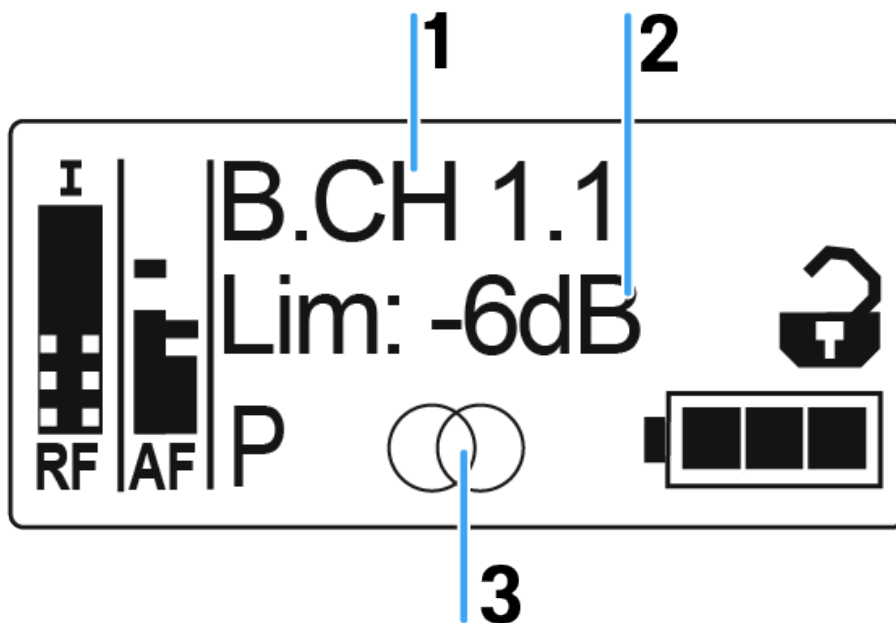

1 Frequency bank and channel:

see [Frequency Preset menu item](#)

2 Limiter

see [Advanced -> Pilot Tone menu item](#)

3 Audio channel, stereo

Focus: ○○

see [Mode menu item](#)

### Frequency/High Boost standard display

The **Frequenz/High Boost** standard display also shows the audio channel (Stereo/Focus) and the treble boost.

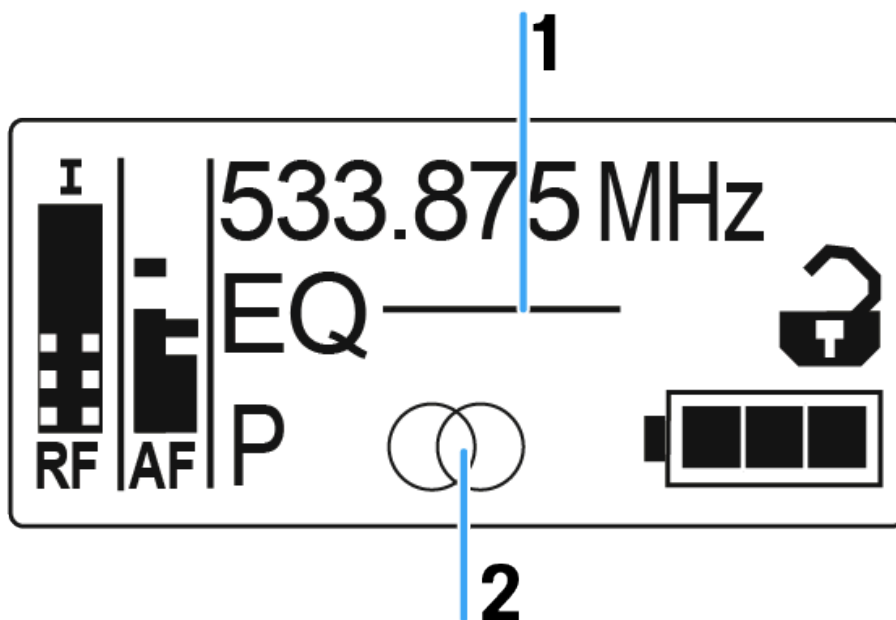

1 Treble boost EQ

see [High Boost menu item](#)

2 Audio channel, stereo







Focus: ○○

see [Mode menu item](#)



## Battery status

Charge status of the batteries:

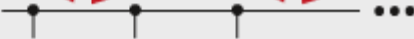
	100 %	> 8 h
	70 %	4 - 6 h
	30 %	2 - 3 h
LOW BATT   		
		

Charge status is critical (LOW BATT):

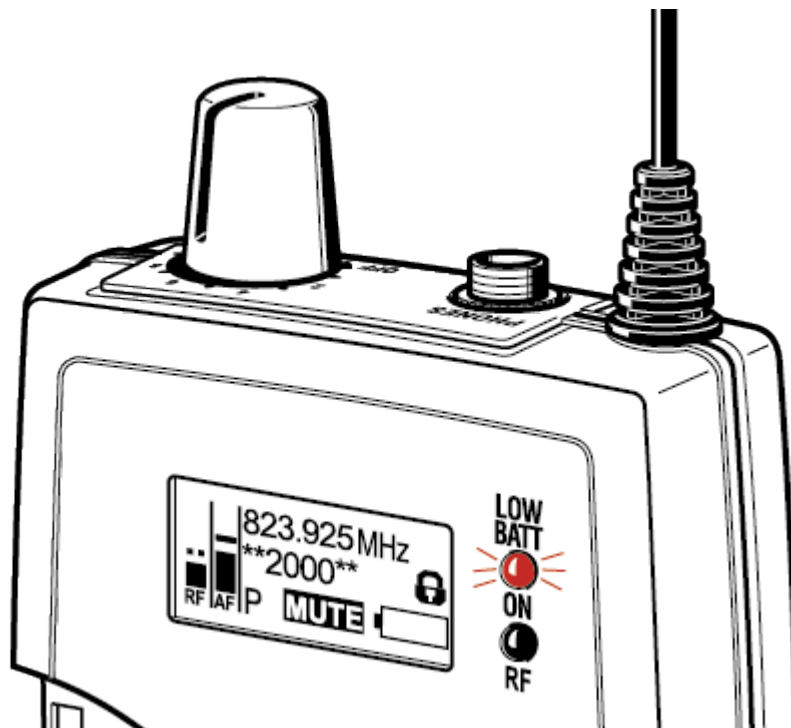



## Buttons for navigating through the menu

To navigate through the EK 2000 IEM operating menu, you need the following buttons.

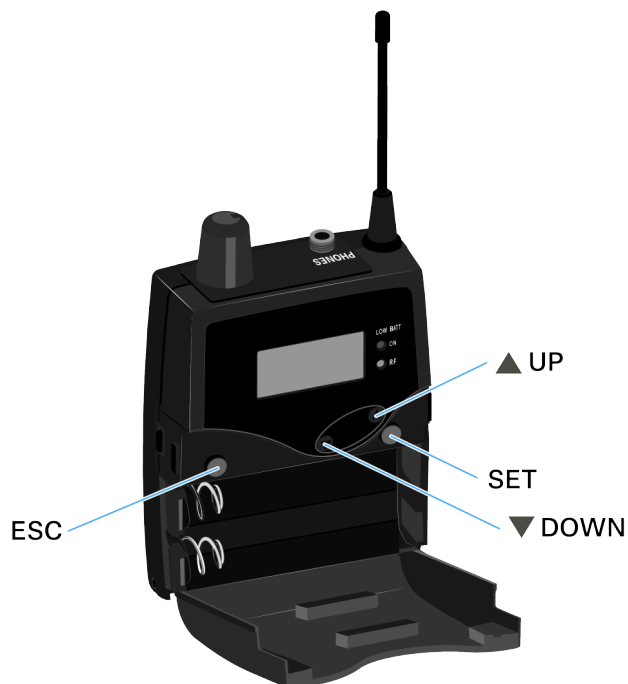

Press the **ESC** button

- Cancels the entry and returns to the current standard display
- Selects a standard display (see [Home Screen](#))



Press the **SET** button

- Changes from the current standard display to the operating menu
- Calls up a menu item
- Changes to a submenu
- Stores the settings and returns to the operating menu (see [Home Screen](#))



Press the **UP** or **DOWN** button

- Changes to the previous or next menu item
- Changes the setting of a menu item
- In Focus mode: Adjusts the balance
- In Stereo mode: Selects a standard display (see [Home Screen](#))



## Menu structure

The figure shows the complete EK 2000 IEM menu structure in an overview.

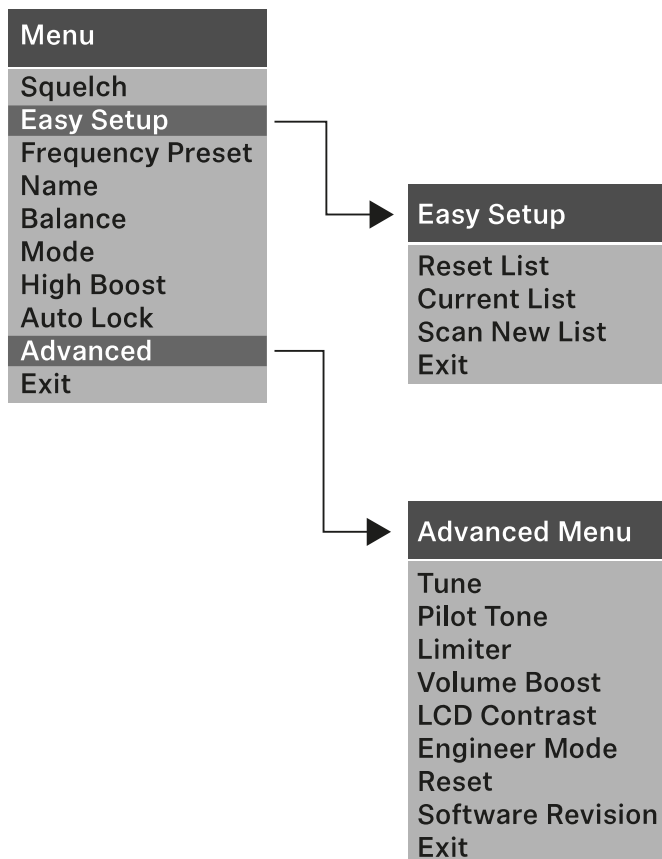



## Setting options in the menu

In the EK 2000 menu, you can configure the following settings.

### Adjusting the squelch threshold

- see [Squelch menu item](#)

### Scanning for unused frequency presets, releases and selects frequency presets

- see [Easy Setup menu item](#)

### Setting the frequency bank and the channel

- see [Frequency Preset menu item](#)

### Entering a freely selectable name

- see [Name menu item](#)

### Adjusting the balance

- see [Balance menu item](#)

### Adjusting Stereo or Focus mode

- see [Mode menu item](#)

### Activating/deactivating the treble boost

- see [High Boost menu item](#)

### Activating/deactivating automatic lock-off function

- see [Auto Lock menu item](#)

### Configuring enhanced settings in the Advanced Menu:

- Setting the receiving frequencies for the frequency banks U1 to U6
- Adjusting the limiter
- Adjusting the volume boost
- Adjusting the contrast of the display panel
- Adjusting the menu item and loading profiles
- Resetting the settings made in the operating menu
- Displaying the current software revision
- see [Advanced menu item](#)

## Squelch menu item

You can adjust the squelch threshold in the Squelch menu item.



**Setting range:**

- 5 - 25 dB $\mu$ V, adjustable in 2 dB steps

The squelch threshold is displayed on the home screen in the RF signal level area:

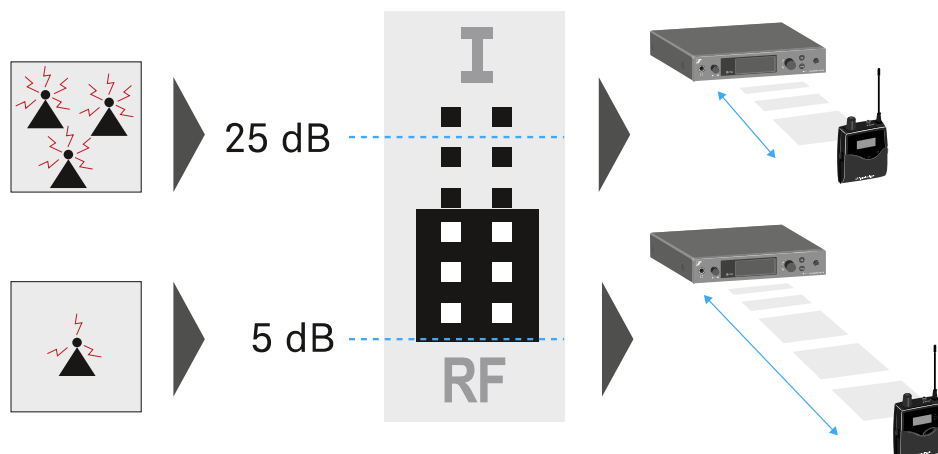

**WARNING**



**Hearing damage due to high volumes**

Higher volumes or longer durations can damage your hearing.

- ▶ Set the volume to a medium level.
- ▶ Reduce the volume level before changing a transmitter or a frequency.

**To open the Squelch menu item:**

- ▶ On the home screen, press the **SET** button to open the operating menu.
- ▶ Press the **UP** or **DOWN** button until the Squelch menu item appears in the selection frame.
- ▶ Press the **SET** button to open the menu item.
- ▶ Adjust the settings as desired.

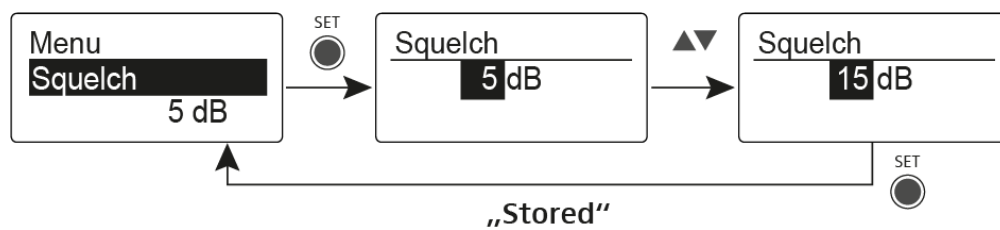

- ▶ Press the **SET** button to save the changes you made to the settings **OR**
- ▶ Press the **ESC** button to cancel the entry without saving the settings.



## Easy Setup menu item

You can scan for unused frequencies using the Easy Setup menu item.

**i** Switch off all transmitters before you perform the scan. If transmitters are still switched on, they are detected as unavailable frequencies and the frequencies that are actually available cannot then be used.

**i** The squelch threshold setting influences the result. Set the squelch threshold to a low level for as many frequencies as possible, and to a high level for as many safe frequencies as possible ([Squelch menu item](#)).

To open the Easy Setup menu item:

- ▶ Press the **SET** button on the Home Screen to open the operating menu.
- ▶ Press the **UP** or **DOWN** button until the Easy Setup menu item appears in the selection frame.
- ▶ Press the **SET** button to open the menu item.
- ▶ Adjust the settings as desired.

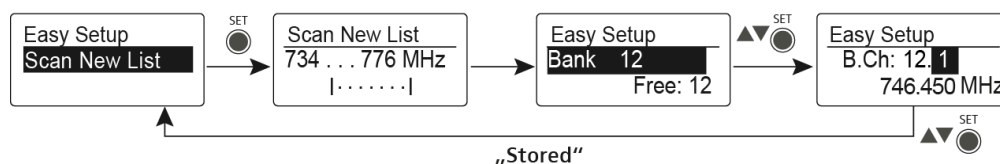

### Scan New List

- ▶ Select Scan New List, to scan for unused frequencies.
- ▶ Press the **SET** button to start the scan.
  - ✓ The frequency range of the receiver is scanned. As a result, the number of unused frequencies is displayed for every frequency bank.
- ▶ Press the **UP** or **DOWN** buttons to select a frequency bank.
- ▶ Press the **SET** button to confirm your selection.
- ▶ Press the **UP** or **DOWN** buttons to select an unused frequency from the selected bank.
- ▶ Press the **SET** button to save the changes you made to the settings. **OR**
- ▶ Press the ESC button to cancel the entry without saving the settings.



### Current List

- ▶ Select Current List to show the list of unused frequencies from the last scan.

### Reset

- ▶ Select Reset List to delete the list of unused frequencies.

### Performing multi-channel frequency setup

**i** As an alternative to the following procedure, multi-channel frequency setup can also be performed using the Sennheiser Wireless Systems Manager (WSM) software. For more information about controlling devices via the Sennheiser Wireless Systems Manager software, refer to the instruction manual for the software.

- ▶ To perform the automatic frequency setup for multiple radio links simultaneously: Connect all of the SR 2000 IEM or SR 2050 IEM transmitters to one network using a network switch. See [Creating a data network](#).
  - ✓ The automatic frequency setup function only works for transmitters in the same frequency range. Transmitters in a different frequency range are not included.
- ▶ Please note that all transmitters must be in the same IP address range.
  - The IP addresses can be automatically assigned if there is a DHCP server in the network.
  - If there is no DHCP server in the network, the IP addresses must be assigned manually. See [Advanced > IP Address menu item](#).
  - Assign the IP addresses for all transmitters in the 192.168.x.x range (the link-local range 169.254.x.x is also a possible alternative).
- ▶ Open the Easy Setup menu item on one of the transmitters.
  - ✓ The **Mute RF For Connected Devices?** message appears.

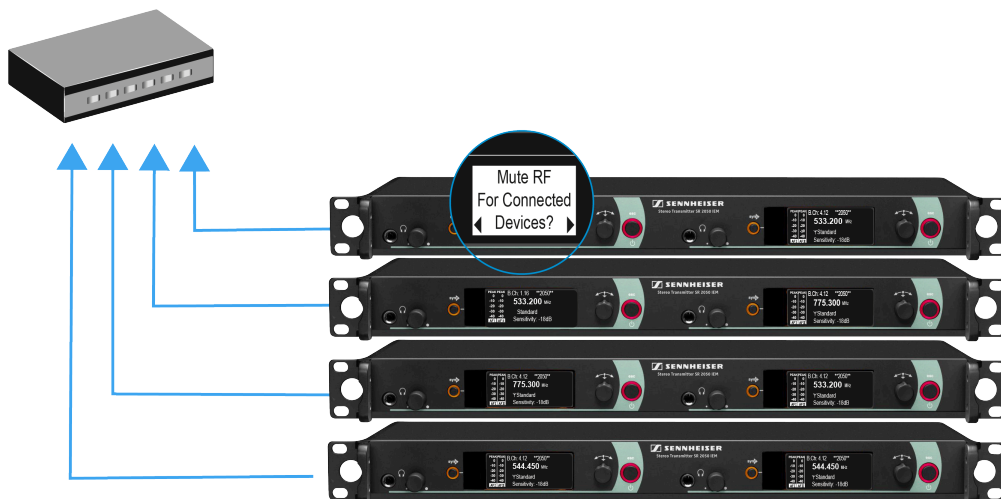



- ▶ Press the jog dial to confirm the message and deactivate the radio signal for all connected transmitters.
  - ✓ All connected transmitters in the same frequency range will switch to Easy Setup Sync mode.

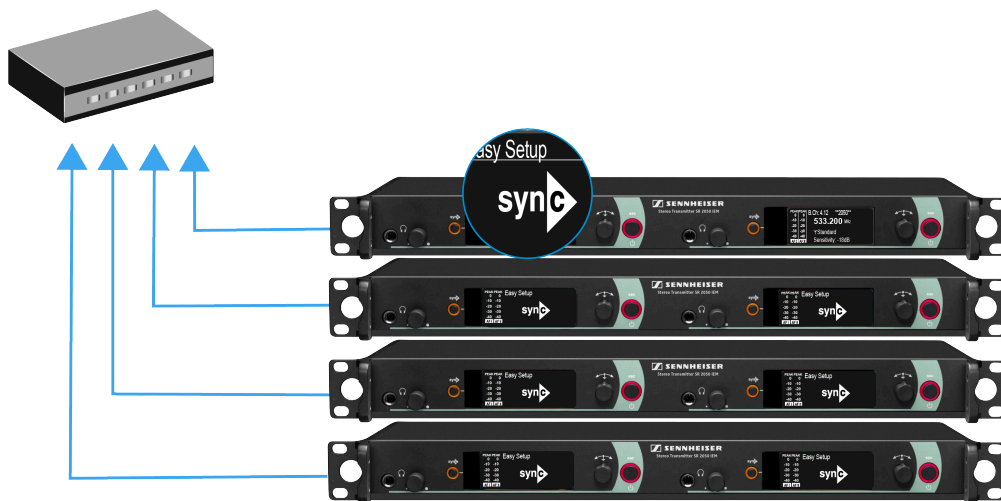

- ▶ Perform a frequency scan on an EK 2000 IEM portable receiver as described above.

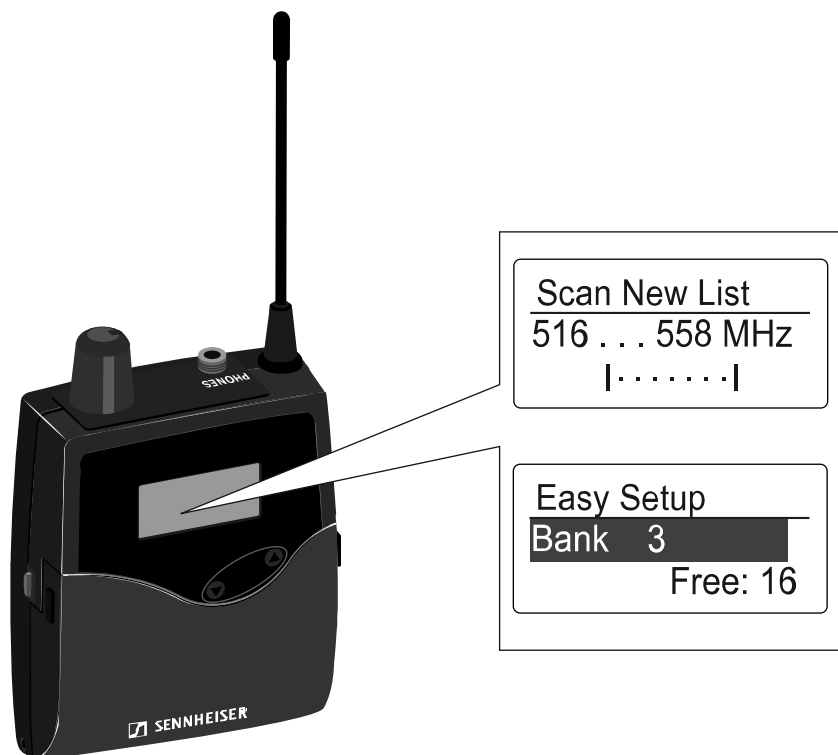

- ▶ From the scan results on the receiver, select a frequency bank with enough free channels.



- ▶ Hold the infrared interface of the EK 2000 IEM receiver in front of the infrared interface of an SR 2000 IEM or SR 2050 IEM transmitter to transfer the scan results from the receiver to this transmitter.



- ✓ The selected transmitter becomes the master transmitter. The display panels of the other transmitters will display the message Assign New Frequency? Receivers with non-compatible frequency ranges will not display a message.



- ▶ Select an unused frequency for one of the connected transmitters on the master transmitter.
- ✓ The frequency selected on the master transmitter will also be shown on the display panel of the connected transmitters.
- ▶ Press the jog dial (**SET**) on the particular transmitter to save your selected frequency and synchronize it with the corresponding receiver at a later point (see [Synchronizing devices](#)). **OR**
- ▶ Press the **SYNC** button to synchronize the selected frequency with the receiver immediately.



- ▶ Use this procedure to assign an unused frequency to all connected transmitters, one after another.
- ▶ For the last step, assign a frequency to the master transmitter.
  - ✔ This completes the multi-channel frequency setup.



## Frequency Preset menu item

In the Frequency Preset menu item, you can adjust the receiving frequency of the receiver by adjusting the frequency bank and the channel.

**i** You can set the frequencies of the frequency bank U here: [Advanced -> Tune menu item](#).

### To open the Frequency Preset menu item:

- ▶ On the home screen, press the **SET** button to open the operating menu.
- ▶ Press the **UP** or **DOWN** button until the Frequency Preset menu item appears in the selection frame.
- ▶ Press the **SET** button to open the menu item.
- ▶ Adjust the settings as desired.

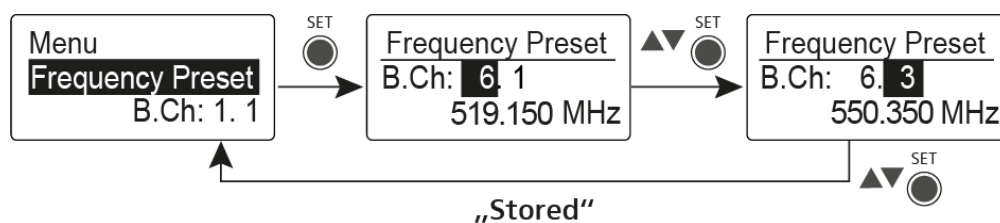

- ▶ Press the **SET** button to save the changes you made to the settings. **OR**
- ▶ Press the **ESC** button to cancel the entry without saving the settings.



## Name menu item

In the Name menu item you can enter a name for the radio link.

To open the Name menu item:

- ▶ On the home screen, press the **SET** button to open the operating menu.
- ▶ Press the **UP** or **DOWN** button until the Name menu item appears in the selection frame.
- ▶ Press the **SET** button to open the menu item.
- ▶ Adjust the settings as desired.

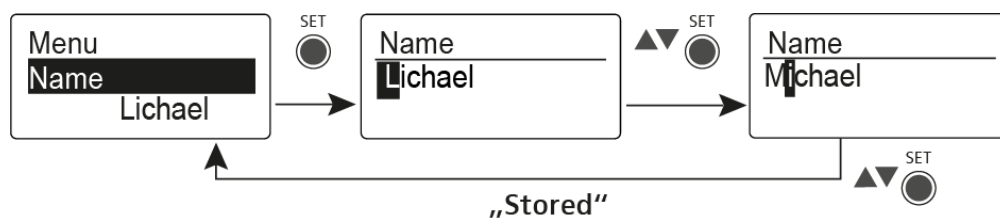

- ▶ Press the **SET** button to save the changes you made to the settings **OR**
- ▶ Press the **ESC** button to cancel the entry without saving the settings.



## Balance menu item

In the Balance menu item you can adjust the balance of the audio channels.

Setting range: 1 steps: L = R, L1 to L15 and R1 to R15

### To open the Balance menu item:

- ▶ On the home screen, press the **SET** button to open the operating menu.
- ▶ Press the **UP** or **DOWN** button until the Balance menu item appears in the selection frame.
- ▶ Press the **SET** button to open the menu item.
- ▶ Adjust the settings as desired.

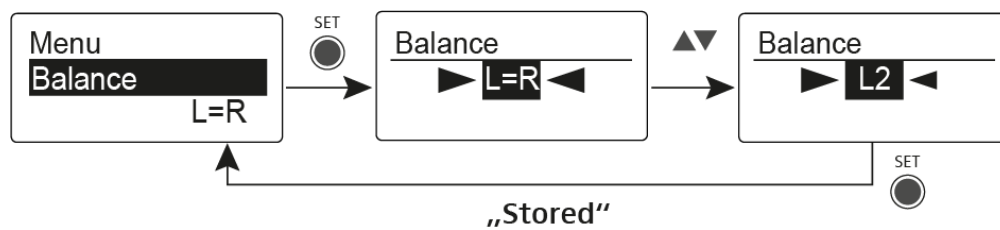

- ▶ Press the **SET** button to save the changes you made to the settings **OR**
- ▶ Press the **ESC** button to cancel the entry without saving the settings.



## Mode menu item

In the Mode menu item you can switch between Stereo and Focus.

Stereo  mode

- i** The left-right signals are available as usual. The Balance setting serves to adjust the balance between the left and right stereo signal (see [Balance menu item](#)).

- ▶ To use it, activate Stereo mode on the corresponding SR 2000 IEM / SR 2050 IEM transmitter den Modus Stereo (see [Mode menu item](#)).

Focus  mode

- ▶ The corresponding SR 2000 IEM / SR 2050 IEM transmitter operates in Stereo mode. The left-right signals are mixed and are available as a mono signal in both headphone channels. The balance setting serves to adjust the relative levels of the two separate channels in the mixed mono signal. See [Balance menu item](#).
- ▶ The corresponding SR 2000 IEM / SR 2050 IEM transmitter operates in Mono mode. Only the left audio input of the SR 2000 IEM / SR 2050 IEM is received as a mono signal.

To open the Mode menu item:

- ▶ On the home screen, press the **SET** button to open the operating menu.
- ▶ Press the **UP** or **DOWN** button until the Mode menu item appears in the selection frame.
- ▶ Press the **SET** button to open the menu item.
- ▶ Adjust the settings as desired.

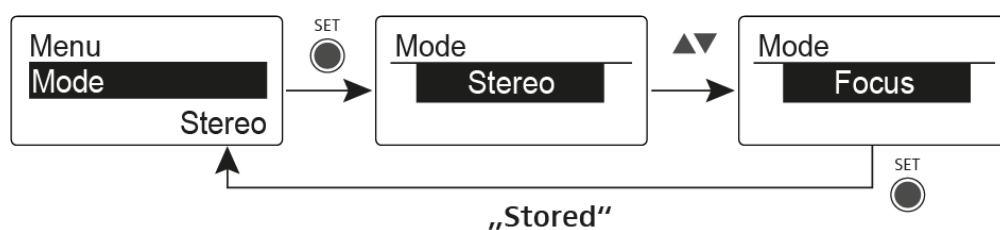

- ▶ Press the **SET** button to save the changes you made to the settings. **OR**
- ▶ Press the **ESC** button to cancel the entry without saving the settings.



## High Boost menu item

In the High Boost menu item you can change the treble boost of the output signal.

Setting range:

- 8 dB at 10 kHz

To open the High Boost menu item:

- ▶ On the home screen, press the **SET** button to open the operating menu.
- ▶ Press the **UP** or **DOWN** button until the High Boost menu item appears in **SET** selection frame.
- ▶ Press the **SET** button to open the menu item.
- ▶ Adjust the settings as desired.

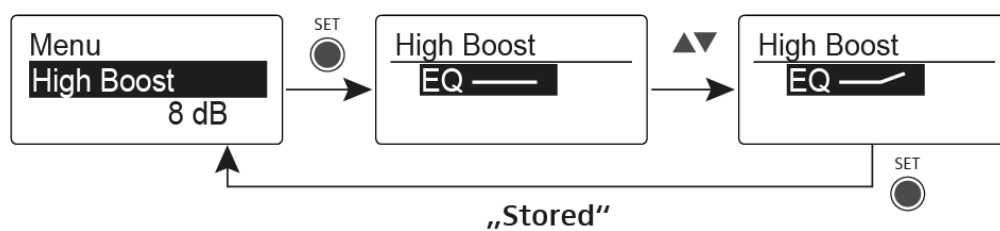

- ▶ Press the **SET** button to save the changes you made to the settings **OR**
- ▶ Press the **ESC** button to cancel the entry without saving the settings.



## Auto Lock menu item

In the Auto Lock menu item you can activate or deactivate the auto lock-off function.

- i** You can find information about temporarily deactivating the lock-off function during operation under [Lock-off function](#).

### To open the Auto Lock menu item:

- ▶ On the home screen, press the **SET** button to open the operating menu.
- ▶ Press the **UP** or **DOWN** button until the Auto Lock menu item appears in the selection frame.
- ▶ Press the **SET** button to open the menu item.
- ▶ Adjust the settings as desired.

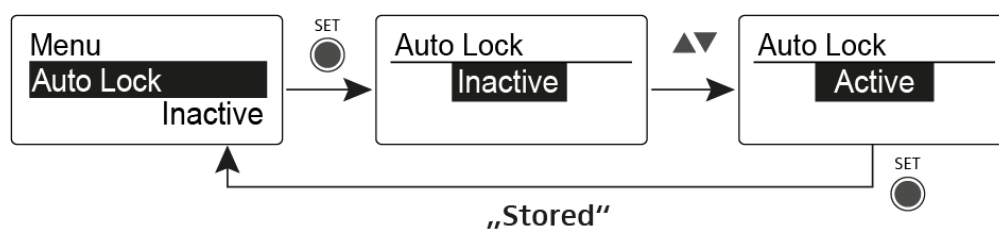

- ▶ Press the **SET** button to save the changes you made to the settings **OR**
- ▶ Press the **ESC** button to cancel the entry without saving the settings.



## Advanced menu item

In the Advanced submenu you can configure enhanced settings.

**To open the Advanced submenu:**

- ▶ On the home screen, press the **SET** button to open the operating menu.
- ▶ Press the **UP** or **DOWN** button until the Advanced menu item appears in the selection frame.
- ▶ Press the **SET** button to open the menu item.

The following sub-items are available:

### **Adjusting the receiving frequency for the frequency bank U**

- see [Advanced -> Tune menu item](#)

### **Adjusting the Pilot Tone**

- see [Advanced -> Pilot Tone menu item](#)

### **Adjusting the limiter**

- see [Advanced -> Limiter menu item](#)

### **Adjusting the volume boost**

- see [Advanced -> Volume Boost menu item](#)

### **Adjusting the contrast of the display panel**

- see [Advanced -> LCD Contrast menu item](#)

### **Adjusting the menu item and loading profiles**

- see [Advanced -> Engineer Mode menu item](#)

### **Resetting the receiver**

- see [Advanced -> Reset menu item](#)

### **Displaying the current software revision**

- see [Advanced -> Software Revision menu item](#)



## Advanced -> Tune menu item

In the Tune menu item of the Advanced submenu, you can configure the receiving frequencies for the frequency banks U1 to U6.

You can save a total of 16 frequencies in every U frequency bank.

### Only adjusting the frequency

- ▶ Open the Tune menu item in the Advanced menu.
- ▶ Adjust the settings.

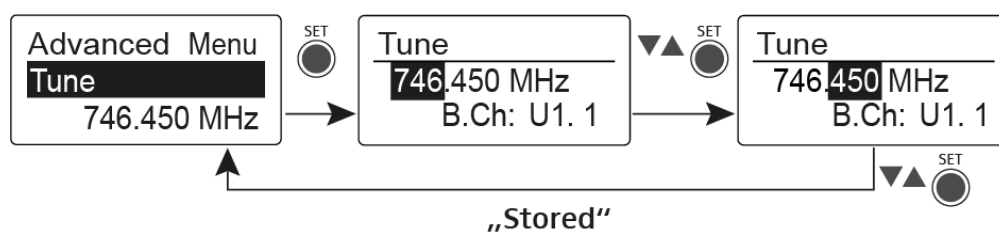

- ▶ Press the **SET** button to save the changes you made to the settings. **OR**
- ▶ Press the **ESC** button to cancel the entry without saving the settings.

### Setting the channel and frequency

- ▶ Select the Tune menu item and call it up by holding down the **SET** button until the channel selection appears.
- ▶ Adjust the settings.

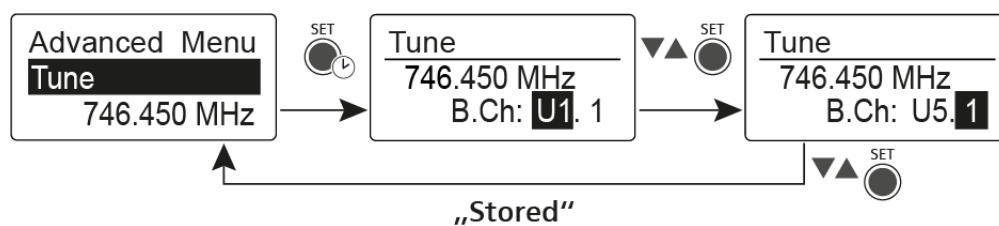

- ▶ Press the **SET** button to save the changes you made to the settings. **OR**
- ▶ Press the **ESC** button to cancel the entry without saving the settings.



### Advanced -> Pilot Tone menu item

In the Pilot Tone menu item of the Advanced submenu, you can activate and deactivate the pilot tone evaluation.

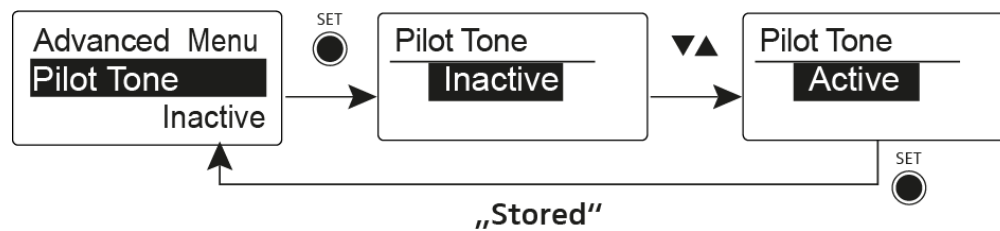

The Pilot Tone has an inaudible frequency which is transmitted by the transmitter and evaluated by the receiver. It supports the squelch function of the receiver.





## Advanced -> Volume Boost menu item

In the Volume Boost menu item of the Advanced submenu, you can adjust the volume boost.

**i** When configuring the settings, ensure that the audio signal is not distorted.

Setting range:

- 0 dB, +3 dB or +6 dB

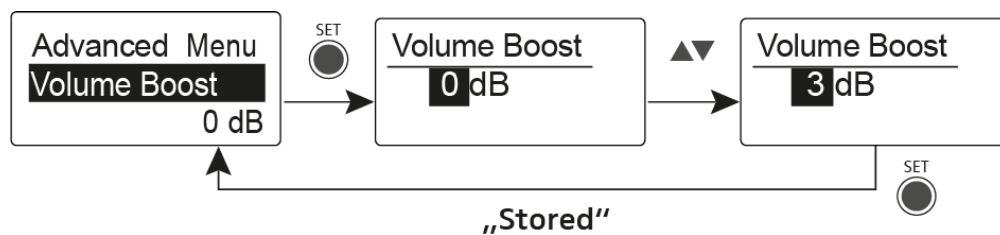



### Advanced -> LCD Contrast menu item

In the LCD Contrast menu item of the Advanced submenu, you can adjust the display contrast of the display panel.





## Advanced -> Engineer Mode menu item

In the Engineer Mode menu item of the Advanced submenu, you can configure the menu items and upload profiles.

In Engineer Mode, you can use your EK 2000 IEM to read out settings from other EK receivers and save them as profiles.

You can load these profiles during a live transmission in order to monitor and, if necessary, adjust an audio signal reproduced by a read-out EK receiver.

A profile contains the settings of the menu items:

- [Squelch menu item](#)
- [Frequency Preset menu item](#)
- [Name menu item](#)
- [Balance menu item](#)
- [Mode menu item](#)
- [High Boost menu item](#)
- [Advanced -> Tune menu item](#)
- [Advanced -> Pilot Tone menu item](#)
- [Advanced -> Volume Boost menu item](#)

### Profiles List menu item

- Create up to 16 profiles and read out the settings of the different EK receivers.

### Load Profiles menu item

- Activate/deactivate profile loading.

### Clear List menu item

- Delete all profiles.

### Profiles List - To read out settings and save them as a profile:

- ▶ Call up the Engineer Mode menu item in the Advanced menu.
- ▶ Call up the Profiles List menu item.
- ▶ Select an unused profile (a profile without a frequency entry).
- ▶ Press the **SET** button.
  - ✓ **sync** appears on the display panel of the receiver.
- ▶ Place the receiver's infra-red interface in front of the infra-red interface of another EK receiver.
  - ✓ The settings of the receiver are assigned to the selected profile.



- ▶ Repeat this procedure to create profiles of other EK receivers.  
You can read out the data of an SR IEM transmitter in the same way. Please note, however, that these settings will only be up-to-date if transmitter and receiver have been synchronized before ([Synchronizing devices](#)).  
When the factory default settings are restored ([Advanced -> Reset menu item](#)), all profiles are deleted.

**Load Profiles - To select a saved profile:**

- ▶ Call up the Load Profiles menu item in the Engineer Mode submenu.
- ▶ Select Active to activate the loading of the profiles.
  - ✓ E appears on the standard display.
- ▶ Press the **ESC** button to exit the menu item.
- ▶ Select a profile by pressing the UP/DOWN button on the standard display. The selected profile is loaded; you hear the audio signal of the corresponding receiver.

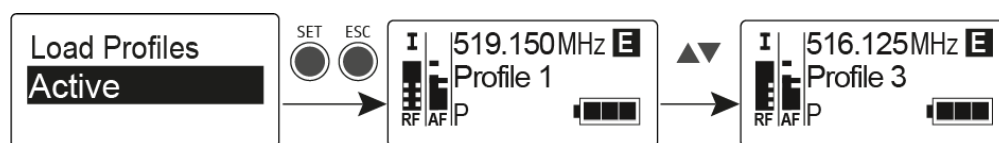

Engineer Mode remains activated, even if you replace the batteries or switch the EK off and on again.



### Advanced -> Reset menu item

In the Reset menu item of the Advanced submenu, you can reset the settings of the receiver to the factory settings.

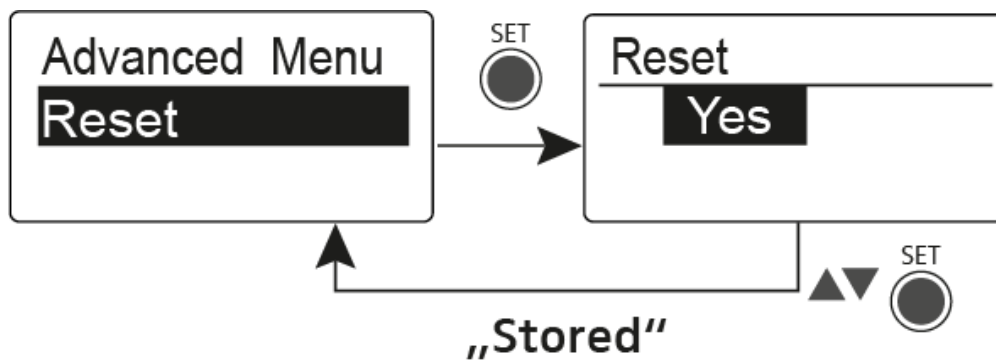



## Advanced -> Software Revision menu item

In the Software Revision menu item of the Advanced submenu, you can display the current software version of the receiver.



## Stereo transmitter SR 2000 IEM | SR 2050 IEM

### Product overview

#### Front

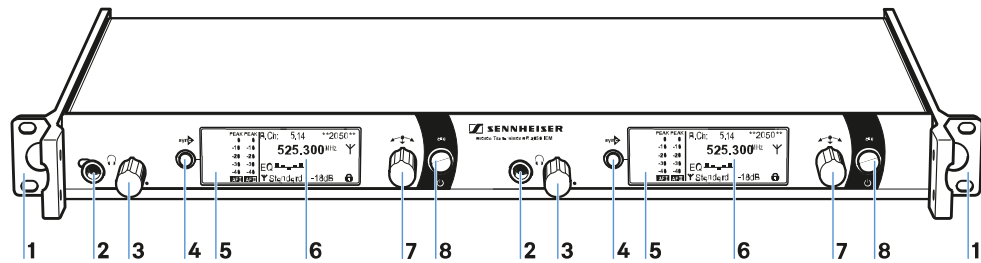

1 Rack mount „ear“

see [Mounting the transmitter into a rack](#)

2 Headphone socket

see [Using the headphone output](#)

3 Volume control for the headphone socket

see [Using the headphone output](#)

see [Synchronizing devices](#)

4 SYNC button

see [Synchronizing devices](#)

5 Infrared interface with a blue LED

see [Synchronizing devices](#)

6 Display panel

see [Displays on the transmitter display panel](#)

7 Jog dial for navigating through the menu

see [Buttons for navigating the transmitter menu](#)

8 STANDBY button

see [Switching the transmitter on and off](#)



Back

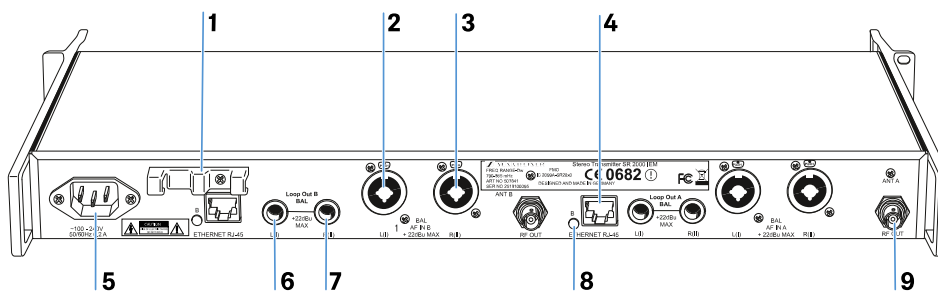

1 Cable grip for power supply DC cable

see [Connecting/disconnecting the transmitter with/from the power supply](#)

2 1/4" (6.3 mm) jack/XLR-3 combo socket BAL AF IN L(I)

Audio input, left

see [Connecting audio signals](#)

3 1/4" (6.3 mm) jack/XLR-3 combo socket BAL AF IN R(II)

Audio input, right

see [Connecting audio signals](#)

4 LAN socket (ETHERNET RJ 45)

see [Creating a data network](#)

5 3-pin mains socket

see [Connecting/disconnecting the transmitter with/from the power supply](#)

6 1/4" (6.3 mm) jack socket LOOP OUT BAL L(I)

Audio output, left

see [Daisy chaining audio signals](#)

7 1/4" (6.3 mm) jack socket LOOP OUT BAL R(II)

Audio output, right

see [Daisy chaining audio signals](#)

8 LED (yellow) for network activity indication\*

9 BNC socket RF OUT

ntenna output

see [Connecting antennas](#)

\* These operating elements are available twice on the SR 2050 IEM twin transmitter and are labeled A and B respectively. A designates the left-hand transmitter, B the right-hand one (seen from the front).



## Connecting/disconnecting the transmitter with/from the power supply

Only use the supplied power supply unit. It is designed for your receiver and ensures safe operation.

### CAUTION

#### Damage due to electric current!

If you connect the transmitter to an unsuitable power supply, this can cause damage to the device.

- ▶ Use the supplied mains cable to connect the transmitter to the mains (100 to 240 V AC, 50 or 60 Hz).
- ▶ Ensure a reliable mains ground connection of the transmitter – especially when you are using multi-outlet power strips or extension cables.

To connect the SR 2000 IEM / SR 2050 IEM transmitter to the power supply:

- ▶ Pass the mains cable through the cable grip.
- ▶ Connect the mains cable to the mains socket.
- ▶ Plug the mains plug into the wall socket.

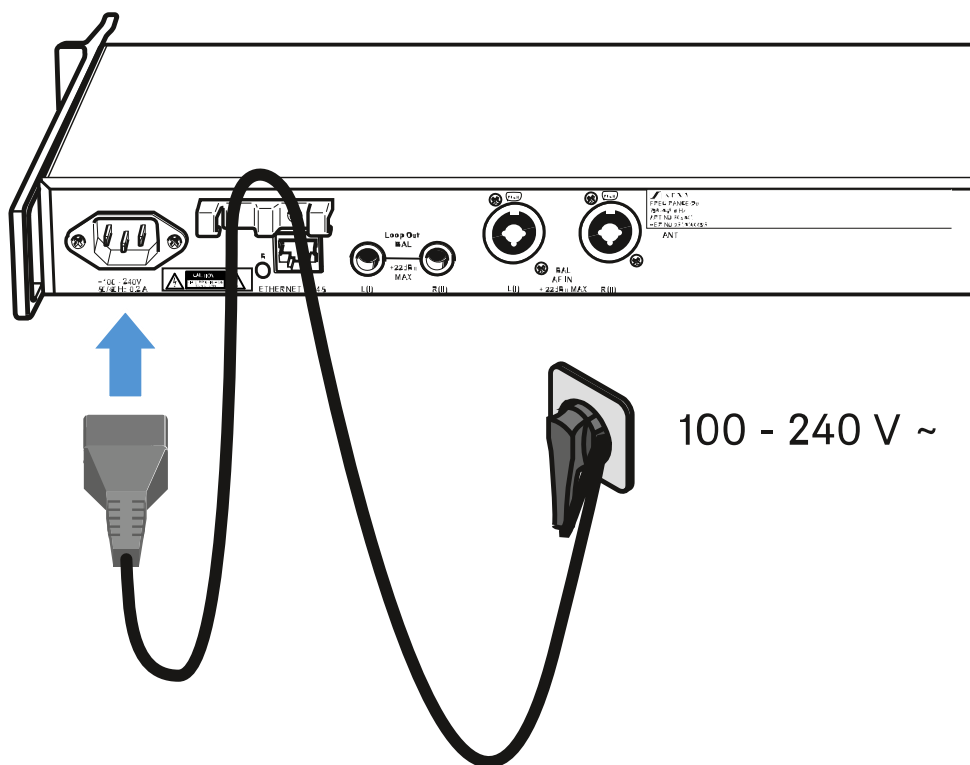



**To disconnect the SR 2000 IEM / SR 2050 IEM transmitter from the power supply:**

- ▶ Unplug the power supply unit from the wall socket.
- ▶ Unplug the mains plug from the wall socket.



## Creating a data network

You can monitor and control one or more SR 2000 IEM / SR 2050 IEM transmitters via a network connection using Sennheiser Wireless Systems Manager (WSM) software.

- i** Automatic frequency setup can also be performed over the network without the WSM software. See [Easy Setup menu item](#).

### To connect the SR 2000 IEM / SR 2050 IEM to a network:

- ▶ Connect a network cable with an RJ-45 connector (to the Ethernet socket on the rear side of the SR 2000 IEM / SR 2050 IEM).
- ▶ Connect the other end of the network cable to a network switch.

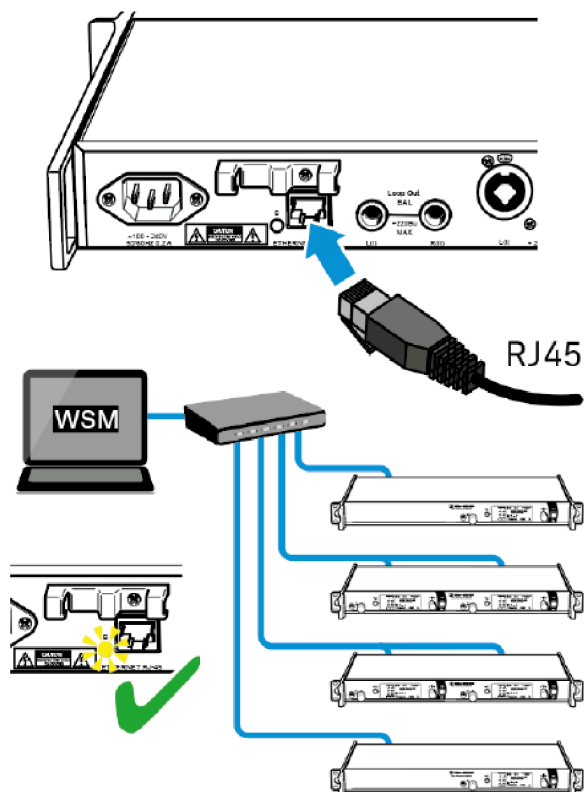

For more information about controlling devices via the Sennheiser Wireless Systems Manager software, refer to the instruction manual for the software. You can download the software here [sennheiser.com/wsm](https://sennheiser.com/wsm).



## Connecting audio signals

You can connect Mono or Stereo signals via the two input sockets BAL AF IN L(I) and BAL AF IN R(II).

To do so, the SR 2000 IEM / SR 2050 IEM must be configured for Mono or Stereo operation in the [Mode menu item](#).

- i** In Stereo mode, you can receive the two input signals either as a mixed mono signal or as a stereo signal. To do so, you must select Focus or Stereo mode on the EK 2000 IEM receiver (see [Mode menu item](#)).

### Mono

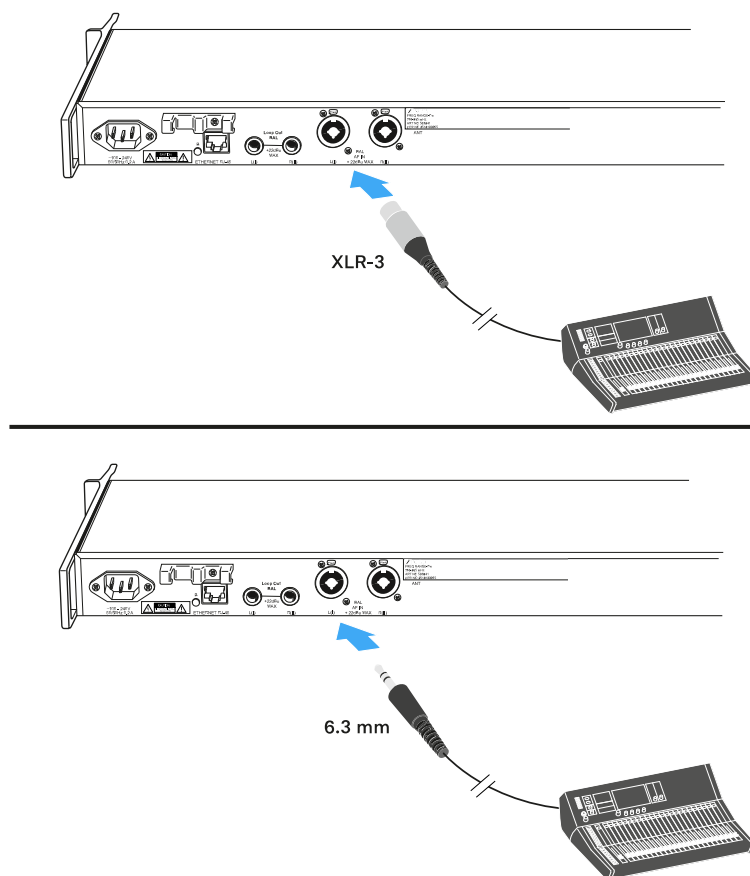

- ▶ Connect the output of an external device (e.g. a mixing console or another SR 2000 IEM / SR 2050 IEM) to the audio input socket BAL AF IN L(I) or BAL AF IN L(II).
- ▶ Via the operating menu, adjust the transmitter's input sensitivity.



- ✓ The input sensitivity is adjusted via the [Sensitivity menu item](#) and is common for both inputs.

**i** In Mono mode, the corresponding EK 2000 IEM receiver must be operated in Focus mode. See [Mode menu item](#).

### Stereo

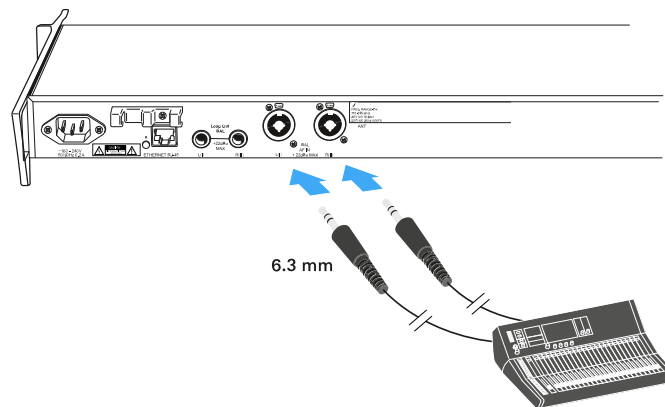
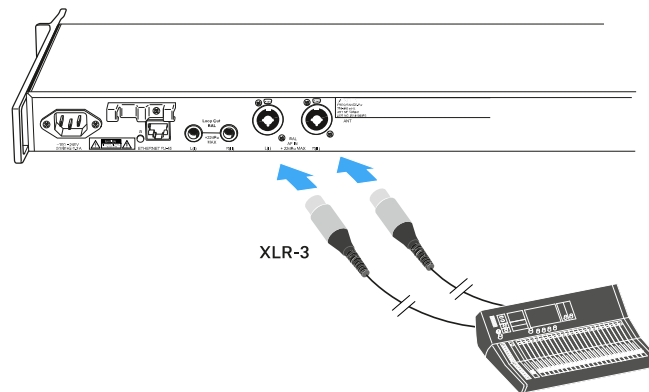

- ▶ Connect the output of an external device (e.g. a mixing console or another SR 2000 IEM / SR 2050 IEM) to the audio input sockets BAL AF IN L(I) and BAL AF IN R(II).

**i** In Stereo mode, the corresponding EK 2000 IEM receiver can be operated in Focus mode or Stereo mode. See [Mode menu item](#).



## Daisy chaining audio signals

Using the LOOP OUT BAL L and/or LOOP OUT BAL R output sockets, it is possible to transmit a signal that you want to make available to all receivers from the mixing console to a transmitter and then to daisy chain this signal from the transmitter to the other transmitters.

In this way, for example, you can distribute an AUX path from the mixing console in Focus mode to multiple transmitters and output a separate signal on the other channel of the same transmitter (e.g. for the individual musician).

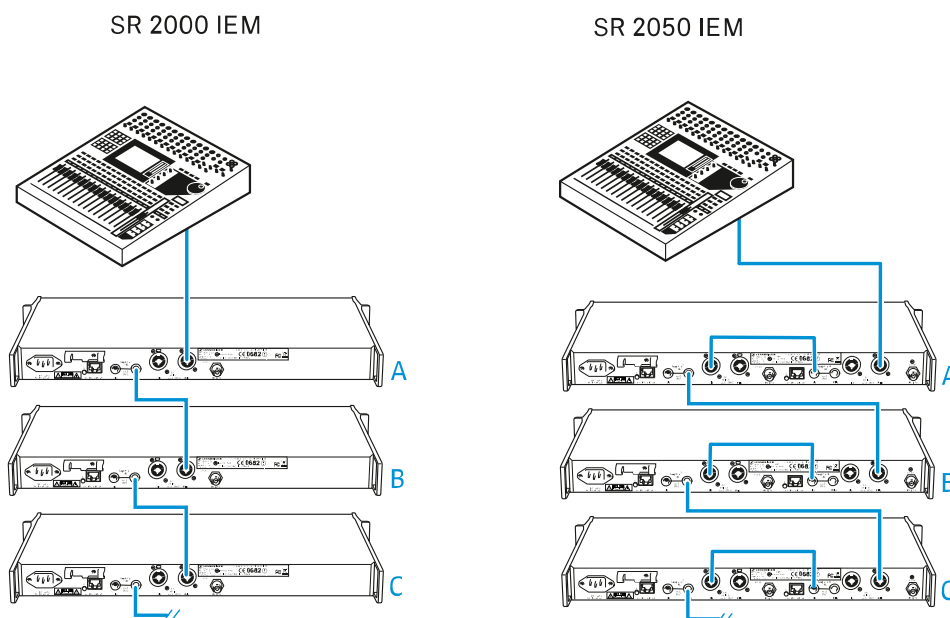

**i** The AF output sockets LOOP OUT BAL L and/or LOOP OUT BAL R will work only when the transmitter is switched on and powered.

- ▶ Transmit a signal from the mixing console to the input socket of transmitter **A** (in this example: BAL AF IN R).
- ▶ Connect the LOOP OUT BAL R output socket of transmitter **A** with the BAL AF IN R input socket of transmitter **B**.
- ▶ Now connect the LOOP OUT BAL R output socket of transmitter **B** with the BAL AF IN R input socket of transmitter **C**.
- ▶ Continue on in this way for the remaining transmitters.



## Connecting antennas

**i** If you are using more than one transmitter, we recommend using remote antennas and the AC 3200-II antenna combiner. You can find more information here:

- [Antenna Combiner AC 3200-II](#)
- [Connecting antennas](#)

For professional use, we recommend connecting a remote antenna and, if necessary, using Sennheiser antenna accessories.

If the transmitter is to be put into operation without a large amount of installation work, you can:

- connect the supplied rod antenna to the rear of the transmitter
- use the optional GA 3030 AM antenna front mount kit.

### Connecting and positioning a remote antenna

**i** Use a remote antenna when the transmitter position is not the best antenna position for optimum transmission. You can choose between two antennas (see [Accessories](#)):

- A 2003 UHF passive directional broadband antenna
- A 1031 passive omni-directional broadband antenna

- ▶ Use a low-attenuation 50  $\Omega$  cable to connect the antenna to the transmitter.
- ▶ If possible, use a short antenna cable and as little connections as possible, since long cables and many connectors lead to an attenuation of the antenna signal.
- ▶ Position the antenna in the same room in which the transmission takes place.



- ▶ Observe a minimum distance of 1 m between the antenna and metal objects (including reinforced concrete walls).

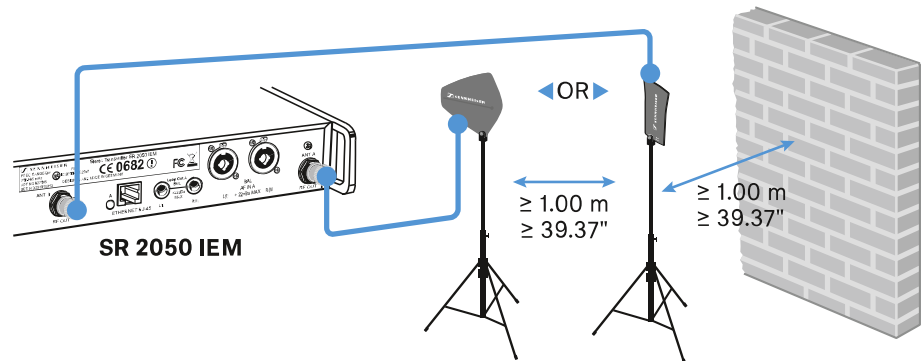

#### Connecting several transmitters to a remote antenna

- i** To make multi-channel systems, you should use the AC 3200 antenna combiner (optional accessory). The AC 3200 allows you to operate up to eight transmitters with a single antenna without virtually any intermodulation.

- ▶ Connect the AC 3200 antenna combiner to the BNC socket (see [Connecting the AC 3200-II with transmitters](#)).

#### To connect the rod antenna to the rear of the transmitter:

- i** The supplied rod antenna & is suitable for all applications where the transmitter is to be put into operation without a large amount of installation work.

- ▶ Connect the rod antenna to the BNC socket RF OUT on the rear panel of the SR 2000 IEM / SR 2050 IEM transmitter.

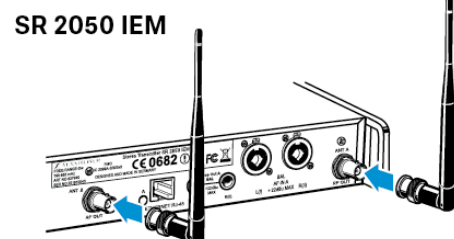
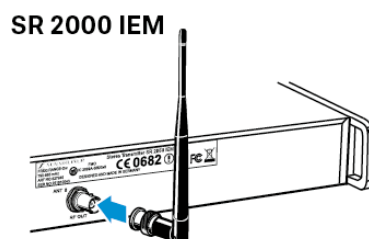



**To mounting the antennas to the front of the rack:**

**i** To mount the antenna connections to the front of the rack when rack mounting the transmitter, you require the GA 3030 AM antenna front mount kit ([Antennas and accessories](#)).

- ▶ Guide the BNC connector of the BNC extension cable through the hole in the rack mount “ear”.
- ▶ Connect the BNC connector to the antenna output.
- ▶ Screw the antenna holder to the BNC socket using the supplied washer and nut.
- ▶ Secure the antenna holder to the rack mount “ear” of the transmitter using two of the supplied screws.

**If you are using the SR 2050 IEM twin transmitter:**

- ▶ Mount the second BNC extension cable in the same way.
- ▶ Slide the transmitter into the 19" rack.
- ▶ Connect the rod antennas to the two BNC sockets.

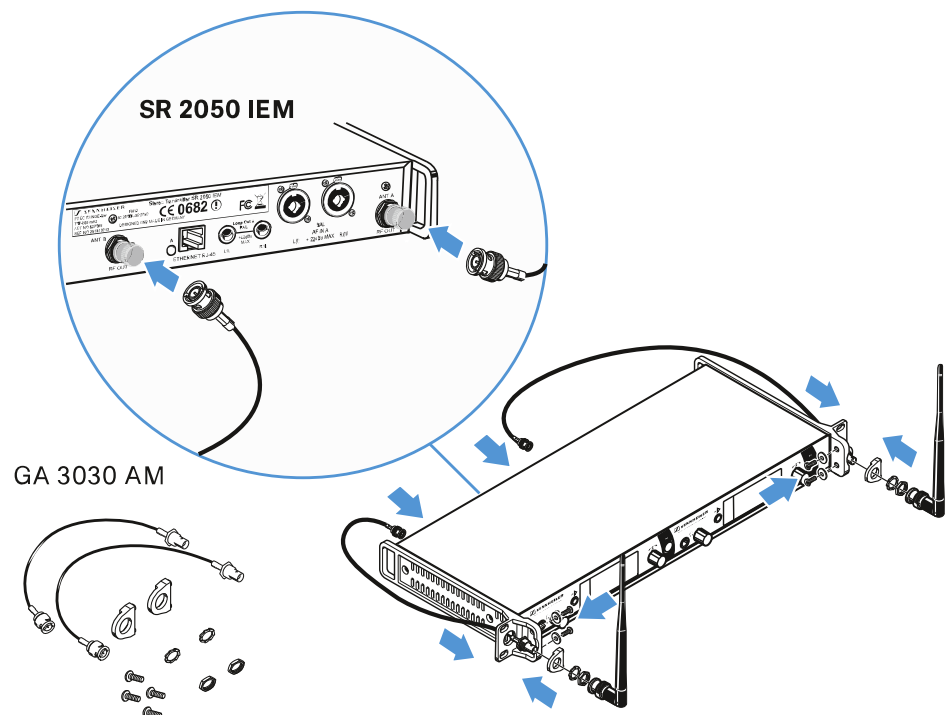



## Mounting the transmitter into a rack

### CAUTION

#### Rack mounting poses risks!

When installing the device in a closed or multi-rack assembly, please consider that, during operation, the ambient Temperature, the mechanical loading and the electrical potentials will be different from those of devices which are not mounted into a rack.

- ▶ Make sure that the ambient Temperature within the rack does not exceed the permissible Temperature limit specified in the specifications. See [Specifications](#).
- ▶ Ensure sufficient ventilation; if necessary, provide additional ventilation.
- ▶ Make sure that the mechanical loading of the rack is even.
- ▶ When connecting to the power supply system, observe the information indicated on the type plate. Avoid circuit overloading. If necessary, provide overcurrent protection.
- ▶ When rack mounting, please note that intrinsically harmless leakage currents of the individual power supply units may accumulate, thereby exceeding the allowable limit value. As a remedy, ground the rack via an additional ground connection.

#### To mount the transmitter into a rack:

- ▶ Slide the transmitter into the 19" rack.
- ▶ Secure the rack mount "ears" to the rack using four screws (not included in the delivery).

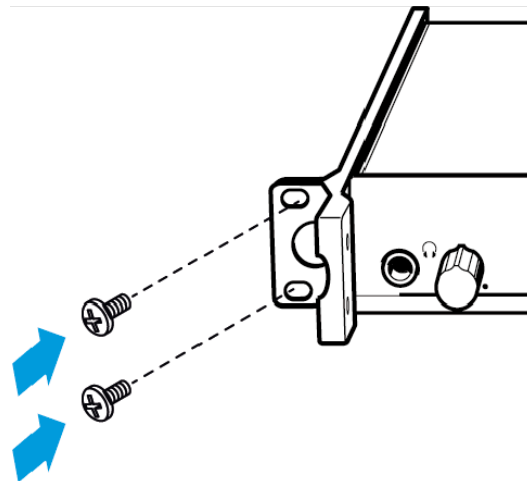



## Switching the transmitter on and off

### To switch on the transmitter:

- ▶ Short-press the **STANDBY** button.



- ✔ The transmitter switches on and the standard display appears.

### To switch the transmitter to standby mode:

- ▶ If necessary, deactivate the lock-off function (see [Lock-off function](#)).
- ▶ Press and hold the **STANDBY** button until **OFF** appears on the display panel.
- ✔ The display panel switches off.

### To completely switch the transmitter off:

- ▶ Disconnect the transmitter from the power supply system by unplugging the power supply unit from the wall socket.



## Using the headphone output

You can use the headphone output on the front of the SR 2000 IEM / SR 2050 IEM (6.3 mm jack) to listen to the audio signal.

### WARNING



#### Danger due to high volume levels

Volume levels that are too high may damage your hearing.

- ▶ Turn down the volume of the headphone output before you put on the headphone.

- ▶ Connect the headphone to the headphone socket.
- ▶ Control the volume by turning the volume control next to the headphone socket.

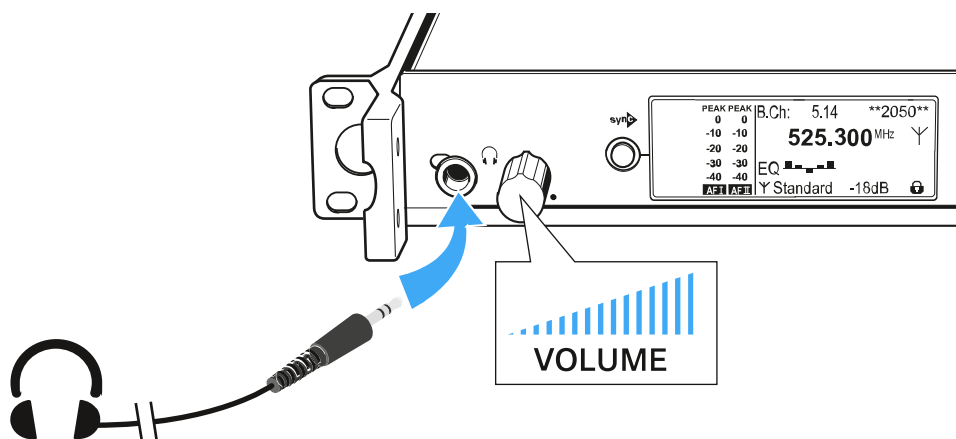



## Configuring the audio channels (mono/stereo)

You can configure audio channels in the [Mode menu item](#). You can select either Stereo or Mono:

- ▶ Select **Stereo** when you want to send a separate audio signal on channel I and channel II (e.g. channel I = audio signal of the moderator/musician, channel II = sum of all audio signals). The moderator/musician then has the option to adjust the volume distribution on his or her receiver as needed.

**i** In Stereo mode, you can receive the two input signals either as a mixed mono signal or as a stereo signal. To do so, you must select Focus or Stereo mode on the EK 2000 IEM receiver.

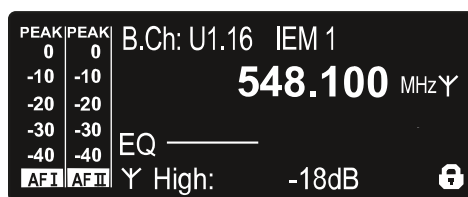

- ▶ Select **Mono** when you only want to transmit one channel. The signal of the left audio input BAL AF IN L is used.

**i** In Mono mode, you have to deactivate the pilot tone evaluation on your EK 2000 IEM receiver. This is the only way to ensure that your receivers will transmit the same signal on channel I and channel II.

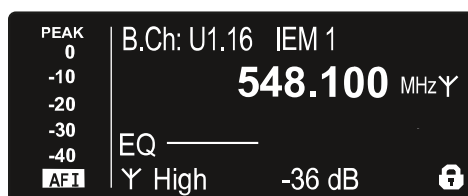



## Deactivating the RF signal (RF mute)

### To deactivate the RF signal:

- ▶ Press the **STANDBY** button.
  - ✓ RF Mute Off? appears in the display panel.
- ▶ Turn the **jog dial**.
  - ✓ RF Mute On? appears in the display panel.
- ▶ Press the **jog dial**.
  - ✓ The transmission frequency is displayed, however the transmitter is not transmitting an RF signal. The RF Mute warning appears (see [Displays on the transmitter display panel](#)) and the LED warnings are illuminated (see [Product overview](#)).

### To activate the RF signal:

- ▶ Press the **STANDBY** button.
  - ✓ RF Mute Off? appears in the display panel.
- ▶ Turn the **jog dial**.
  - ✓ RF Mute On? appears in the display panel.
- ▶ Press the **jog dial**.



- ✓ The RF signal is activated and the LED warnings of the display changes back to orange.

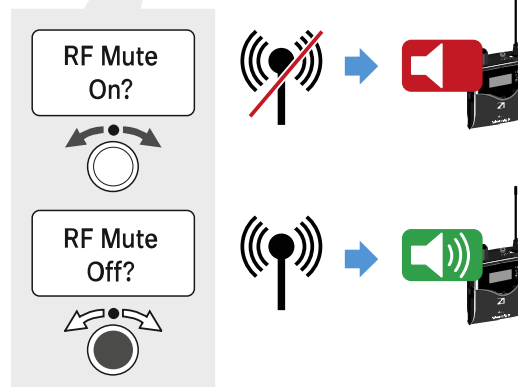
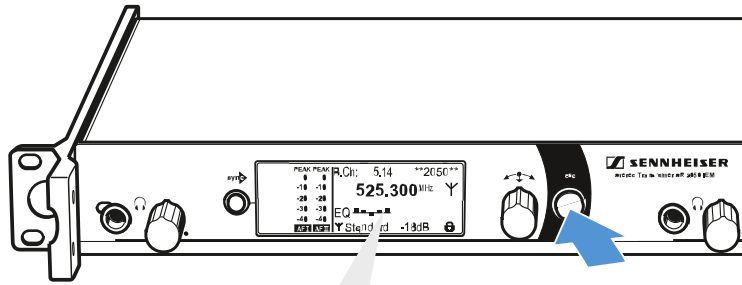



## Lock-off function

You can set the automatic lock-off function in the Auto lock menu (see [Auto Lock menu item](#)).

When you have switched on the lock-off function, you will have to turn the transmitter off and on again in order to operate it.

### To temporarily deactivate the lock-off function:

- ▶ Press the **jog dial**.
  - ✓ Locked appears in the display panel.
- ▶ Turn the **jog dial**.
  - ✓ Unlock? appears in the display panel.
- ▶ Press the **jog dial**.
  - ✓ Lock-off function is now temporarily deactivated.

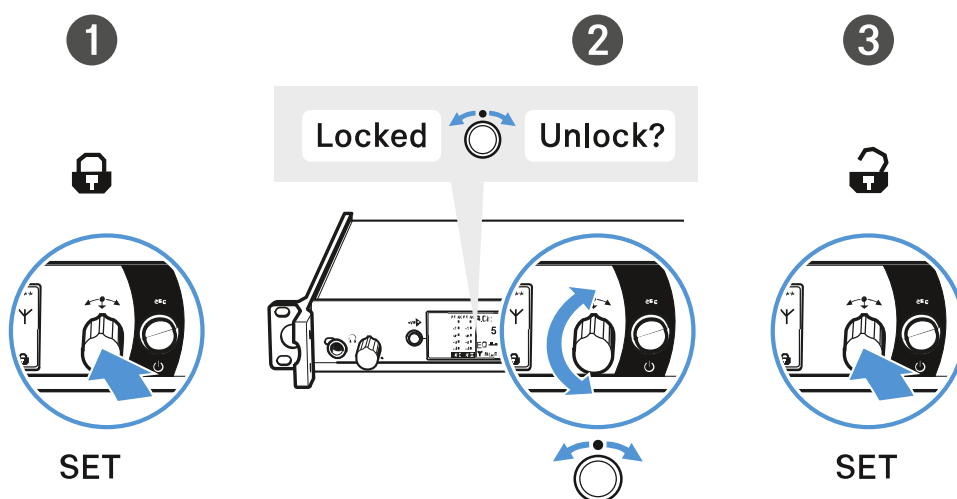

#### When you are in the operating menu

Lock-off function is deactivated long enough for you to work in the operating menu.

#### You are in the standard display

Lock-off function is automatically activated after 10 seconds.

- ✓ The Lock-off function icon flashes while the lock-off function is atng activated again.



## Displays on the transmitter display panel

You can view the following information on the transmitter display.

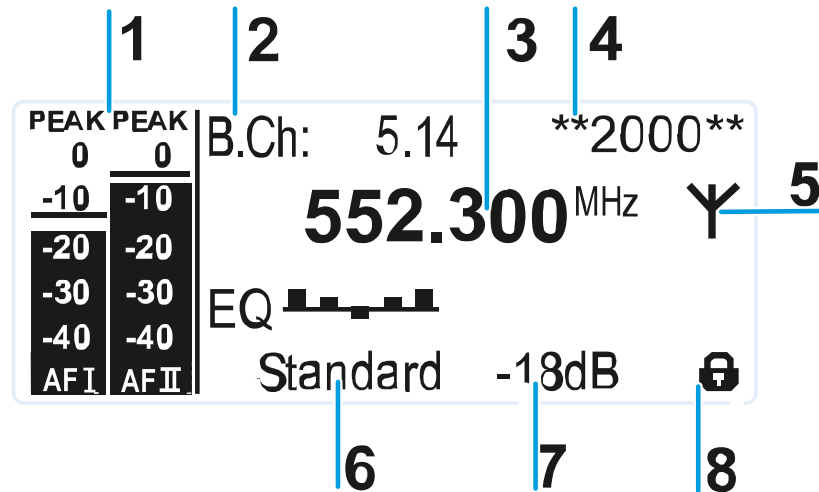

### 1 AF audio level (audio frequency)

Audio channel level with peak hold function

When the display shows full deflection, the audio input level is excessively high. When the transmitter is overloaded frequently or for extended periods of time, the PEAK display is shown inverted.

see [Sensitivity menu item](#)

see [Configuring the audio channels \(mono/stereo\)](#)

### 2 Frequency bank and channel

Current frequency bank and channel number

see [Frequency Preset menu item](#)

### 3 Frequency

Configured transmission frequency

see [Frequency Preset menu item](#)

### 4 Name

Freely selectable name of the receiver

see [Name menu item](#)



**5** Transmission icon and transmission power

RF signal is being transmitted

see [Advanced > RF Power menu item](#)

see [Deactivating the RF signal \(RF mute\)](#)

**6** RF Power

Configured RF Power

**7** Input sensitivity

Configured input sensitivity for the NF signal on the audio input sockets BAL AF IN L (I) and BAL AF IN R (II)

see [Sensitivity menu item](#)

**8** Lock-off function

Lock-off function is activated.

see [Auto Lock menu item](#)



## Buttons for navigating the transmitter menu

Navigating through the menu

**To open the menu:**

- ▶ Press the **jog dial**.
- ✔ The operating menu is shown on the transmitter display panel.

**To open a menu item:**

- ▶ Turn the **jog dial** to navigate through the individual menu items.
- ▶ Press the **jog dial** to open the selected menu item.

**Making changes in a menu item**

**i** After you open a menu item, you can make changes as follows:

- ▶ Turn the **jog dial** to set the displayed value.
- ▶ Press the **jog dial** to save your setting.
- ▶ Press the **ESC** button to leave the menu item without saving the setting.



## Setting options in the menu

In the SR 2000 IEM / SR 2050 IEM menu, you can configure the following settings.

### Adjusting the input sensitivity

- see [Sensitivity menu item](#)

### Configuring the audio transmission mode (mono/stereo)

- see [Mode menu item](#)

### Activating Easy Setup Sync

- see [Easy Setup menu item](#)

### Setting the frequency bank and the channel

- see [Frequency Preset menu item](#)

### Entering a freely selectable name

- see [Name menu item](#)

### Activating/deactivating the automatic lock-off function

- see [Auto Lock menu item](#)

### Configuring enhanced settings in the Advanced Menu:

- Adjusting the transmission frequencies for the U frequency bank
- Adjusting the parameters for transmission to the receivers
- Configuring the transmission power
- Adjusting the warnings
- Adjusting the contrast of the display panel
- Resetting the transmitter
- Configuring the IP address
- Displaying the current software revision
- see [Advanced menu item](#)

## Sensitivity menu item

Adjusting the input sensitivity – AF audio level

Setting range:

- 0 dB to -42 dB in 3 dB steps

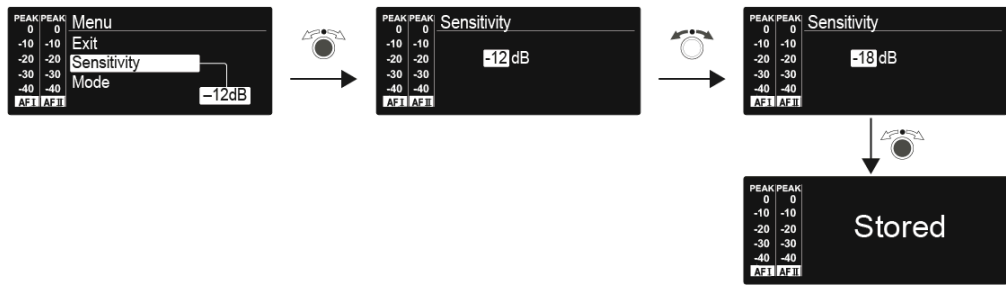



## Mode menu item

Configuring the audio transmission

Setting range:

- Stereo and Mono

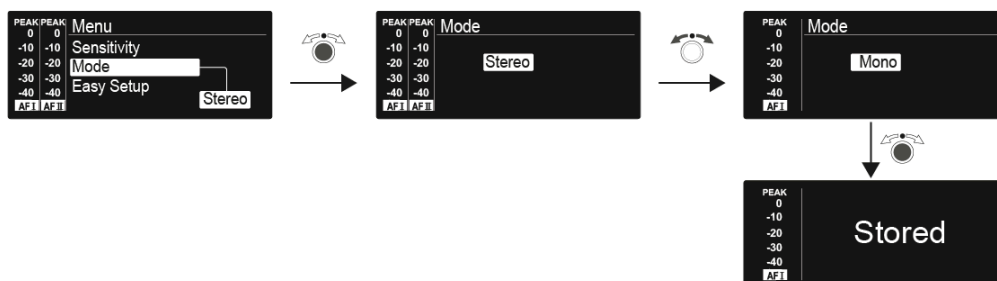

**i** In stereo mode, you can receive the two input signals either as a mixed mono signal or as a stereo signal. To do so, you must select Focus or Stereo mode on the EK 2000 IEM receiver.



## Easy Setup menu item

### Activating Easy Setup Sync

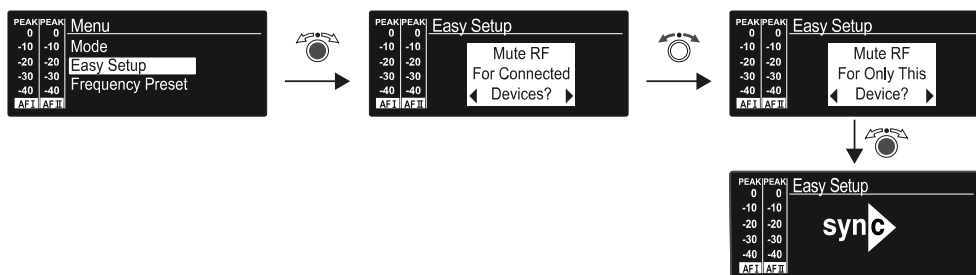

The Easy Setup Sync function is needed to perform a frequency scan using the receiver and for automatic multi-channel frequency setup.

- See [Easy Setup menu item](#) for the EK 2000 IEM receiver.
- See [Synchronizing devices](#)



## Frequency Preset menu item

Manually selecting a frequency bank and channel

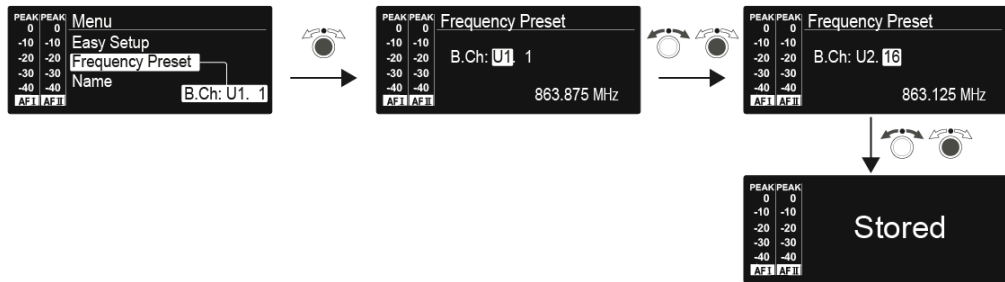



## Name menu item

Entering names



In the Name menu item you can enter any name you want for the transmitters (e.g. the names of the musicians).

**The names are a maximum of 8 characters:**

- All letters except German umlauts.
- Numbers from 0 to 9
- Special characters and spaces

**Enter the names as follows:**

- ▶ Turn the **jog dial** to select a character.
- ▶ Press the **jog dial** to switch to the next position.
- ✓ Once you have entered the last character, press the jog dial to save the name.



## Auto Lock menu item

Switching the automatic lock-off function on and off



This lock prevents the transmitter from being unintentionally switched off and also prevents any unintentional changes to the transmitter's configuration. In the standard display, the lock icon shows whether the lock-off function is currently switched on.

- i** You can find information about using the lock-off function under [Lock-off function](#).



## Advanced menu item

In the Advanced submenu you can configure enhanced settings

The following sub-items are available:

### Adjusting the transmission frequencies for the U frequency bank

- see [Advanced > Tune menu item](#)

### Adjusting the parameters for transmission to the receivers

- see [Advanced > Sync Settings menu item](#)

### Configuring the transmission power

- see [Advanced > RF Power menu item](#)

### Adjusting the warnings

- see [Advanced > Fullscreen Warnings menu item](#)

### Adjusting the contrast of the display panel

- see [Advanced > LCD Contrast menu item](#)

### Resetting the transmitter

- see [Advanced > Reset menu item](#)

### Configuring the IP address

- see [Advanced > IP Address menu item](#)

### Displaying the current software revision

- see [Advanced > Software Revision menu item](#)



## Advanced > Tune menu item

Configuring transmission frequencies and frequency banks U1 to U6.

You can save a total of 16 channels in the frequency banks U1 to U6.

### Only adjusting the frequency

- ▶ Open the Tune menu item in the Advanced menu.
- ▶ Adjust the settings.

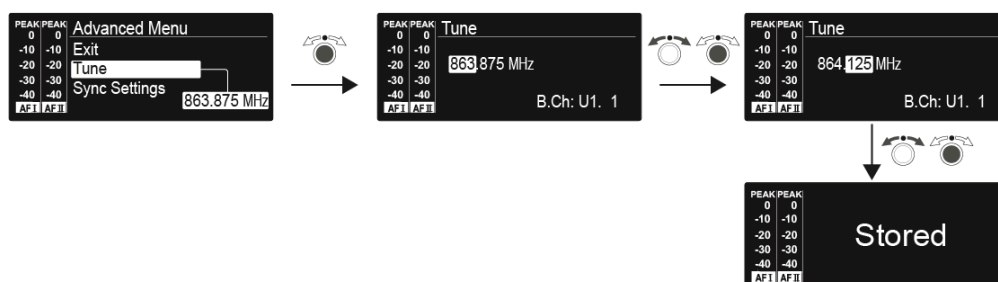

### Setting the channel and frequency

- ▶ Select the Tune menu item and call it up by holding down the **jog dial** until the channel selection appears.
- ▶ Adjust the settings.

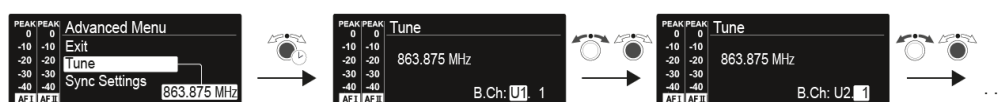



## Advanced > Sync Settings menu item

Configuring, activating or deactivating parameters for transmission to the receivers.

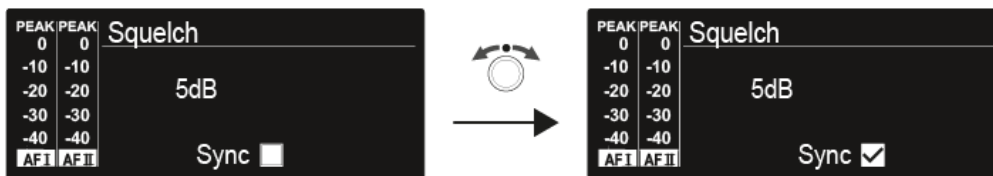

When the check box is activated, the value will be transmitted during synchronization. If it is deactivated, the value will not be transmitted.

**You can configure and activate/deactivate the following parameters:**

- Balance
- Squelch
- Mode
- High Boost
- Auto Lock
- Limiter

See [Synchronizing devices](#).



## Advanced > RF Power menu item

Configuring the transmission power

**Setting range:**

- Low: 10 mW
- Standard: 30 mW
- High: 50 mW

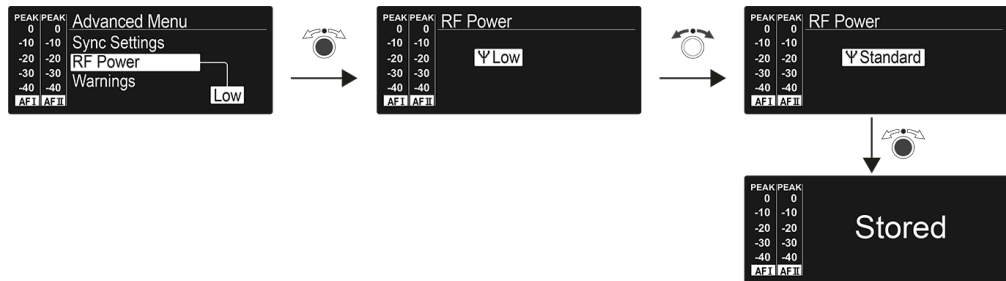

You can configure the transmission power in three steps in the RF Power menu item. Please note the general conditions and restrictions for the use of frequencies: [sennheiser.com/sifa](https://www.sennheiser.com/sifa).

When synchronizing your transmitter with an EK 2000 IEM receiver, please observe the following:

- Only use a transmitter and a receiver from the same frequency range (see the type plate on the transmitter and the receiver).
- Make sure that the desired frequencies are listed in the enclosed frequency information sheet.
- Make sure that the desired frequencies are approved and legal in your country and, if necessary, apply for an operating license.



## Advanced > Fullscreen Warnings menu item

Activating/deactivating warnings



You can activate or deactivate the following warnings:

### AF-Peak

- The audio level is too high.

### RF Mute

- The RF signal from the transmitter to the receiver is deactivated.



## Advanced > LCD Contrast menu item

Adjusting the contrast of the display panel

Setting range:

- 0 to 15

You can configure the contrast of the display in 16 steps.

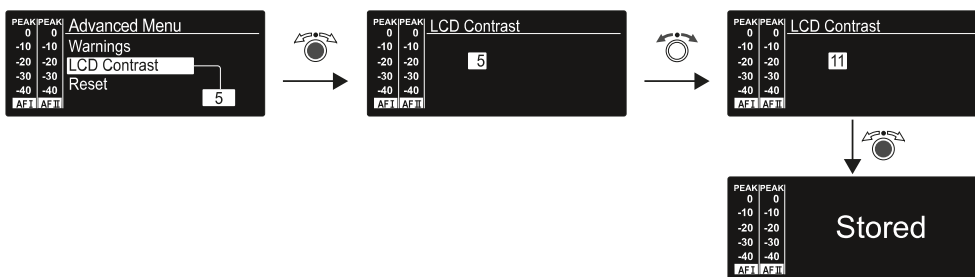



## Advanced > Reset menu item

Resetting the transmitter

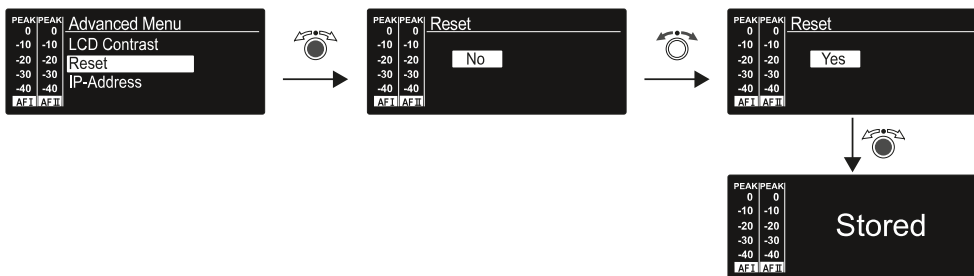

When you reset the transmitter, only the selected settings of the pilot tone and the U1 to U6 frequency banks are retained.



## Advanced > IP Address menu item

Adjusting the network configuration

Setting range:

- Automatic
- manual

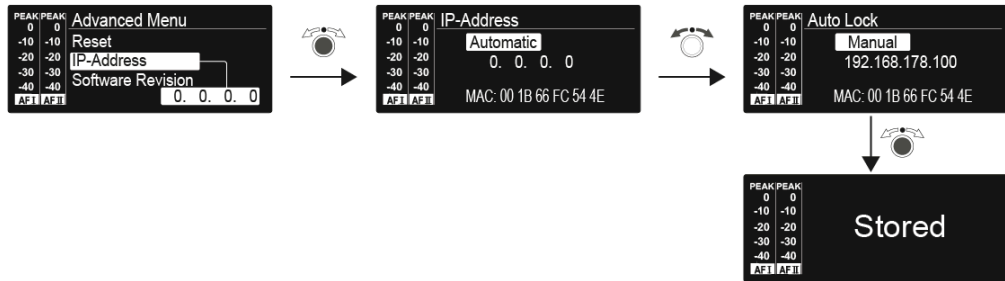



## Advanced > Software Revision menu item

Show software revision

You can display the current software revision.



## Antenna Combiner AC 3200-II

### Product overview

#### Front



**1** Rack mount „ear“

see [Installing the AC 3200-II in a rack](#)

**2** Air vents (on the sides)

see [Installing the AC 3200-II in a rack](#)

**3** 8 LEDs

operation indicators of the RF inputs

see [RF indicators](#)

**4** LED

see [Switching the AC 3200-II on and off](#)

**5** On-/Off switch

see [Switching the AC 3200-II on and off](#)

#### Back

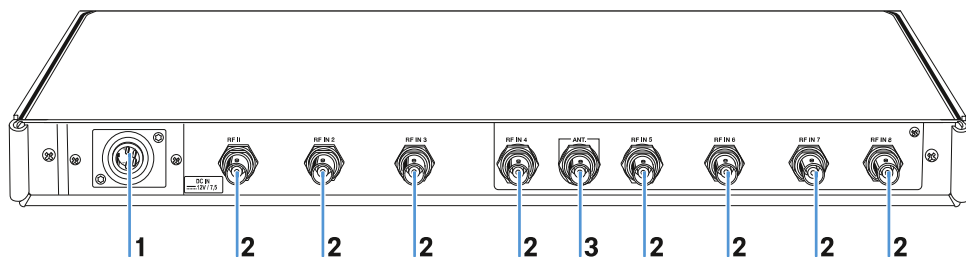

**1** DC IN socket

To connect the NT 12-125D

see [Connecting/disconnecting the AC 3200-II to/from the power supply system](#)



**2 8 RF-Inputs RF IN 1 to RF IN 8**

Antenna input

see [Connecting the AC 3200-II with transmitters](#)

**3 BNC Socket ANT**

Antenna output

see [Connecting antennas](#)



## Connecting/disconnecting the AC 3200-II to/from the power supply system

To supply power to the AC 3200-II, the connected transmitters and any antenna amplifiers used, you will need the NT 12-125D power supply unit.

Only use the supplied NT 12-125D power supply unit. It is designed for your antenna combiner and ensures safe operation.

### To connect the AC 3200-II antenna combiner to the power supply system:

- ▶ Connect the mains cable (EU, UK or US version, depending on your location) to the input socket on the NT 12-125D mains unit.
- ▶ Connect the DC connector of the mains unit to the DC input socket 6 of the AC 3200-II.
- ▶ Connect the mains connector of the mains cable to the mains power supply.

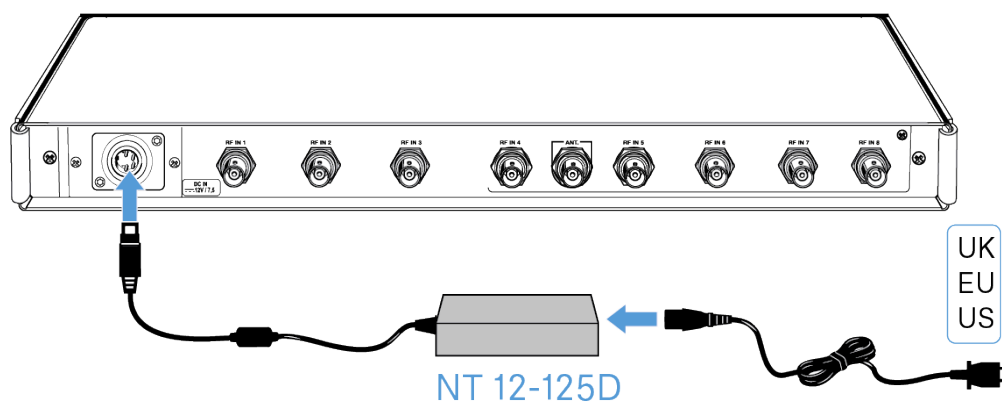

### To completely disconnect the AC 41 antenna combiner from the power supply system:

- ▶ Disconnect the mains cable (EU, UK or US version, depending on your location) from the input socket on the NT 12-125D mains unit.
- ▶ Disconnect the DC connector of the mains unit to the DC input socket 6 of the AC 3200-II.
- ▶ Disconnect the mains connector of the mains cable from the mains power supply.



## Connecting the AC 3200-II with transmitters

The AC 3200 is an active, high-power 8:1 antenna combiner for large multi-channel wireless monitoring systems. The AC 3200-II combines up to eight channels for transmission via one antenna, with a broadband design covering 500 - 870 MHz.

### To connect a transmitter:

- ▶ Connect the BNC cable of the transmitter to one of the eight RF inputs RF IN 1 to RF IN 8.
- ▶ Repeat the previous step until all four transmitters are connected to the antenna combiner.
- ▶ Connect the AC 3200-II to the power supply system (see [Connecting/disconnecting the AC 3200-II to/from the power supply system](#)).

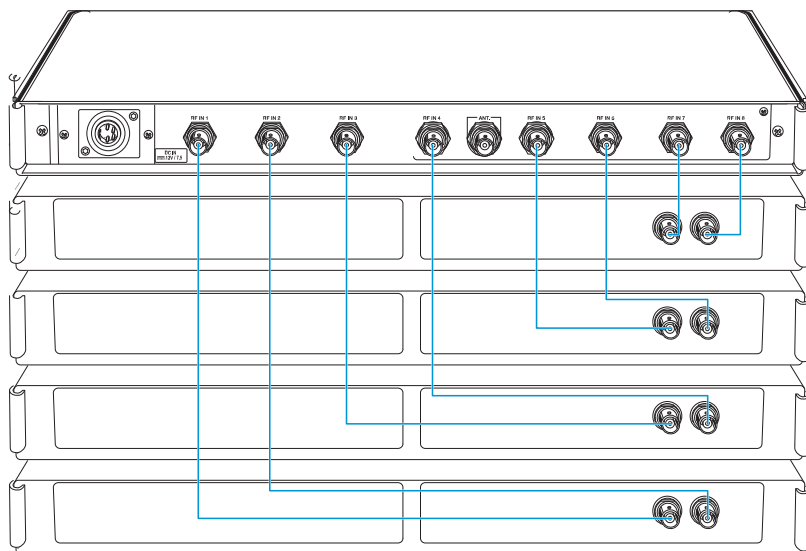



## Connecting antennas

### NOTICE



#### Danger of damage to the devices!

Do not daisy-chain several AC 3200-II. Do not connect other active combiners to the AC 3200-II.

- ▶ Never connect the AC 3200-II to other active combiners.
- ▶ Only connect suitable antennas to the output of the AC 3200-II.

**i** The AC 3200-II active transmitter combiner can be used with either the A 2003 UHF directional antenna, the A 1031 U omni-directional antenna or the A 5000 CP circularly polarized UHF antenna. The antenna transmits the signals of all connected transmitters.

**i** The signals are combined onto the antenna output with no distribution attenuation.

#### To connect an antenna:

- ▶ Connect the antenna using a low-attenuation 50  $\Omega$  coaxial cable.
- ▶ Connect the coaxial cable to the antenna output.

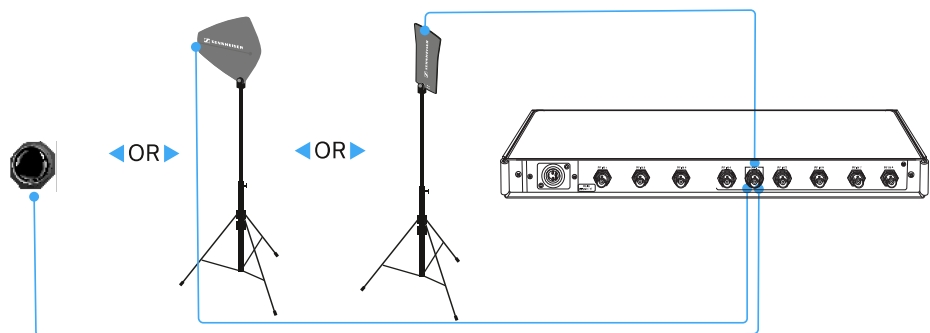



## Installing the AC 3200-II in a rack

### CAUTION

#### Rack mounting poses risks!

When installing the device in a closed or multi-rack assembly, please consider that, during operation, the ambient Temperature, the mechanical loading and the electrical potentials will be different from those of devices which are not mounted into a rack.

- ▶ Make sure that the ambient Temperature within the rack does not exceed the permissible Temperature limit specified in the specifications. See [Specifications](#).
- ▶ Ensure sufficient ventilation; if necessary, provide additional ventilation.
- ▶ Make sure that the mechanical loading of the rack is even.
- ▶ When connecting to the power supply system, observe the information indicated on the type plate. Avoid circuit overloading. If necessary, provide overcurrent protection.
- ▶ When rack mounting, please note that intrinsically harmless leakage currents of the individual power supply units may accumulate, thereby exceeding the allowable limit value. As a remedy, ground the rack via an additional ground connection.

#### To mount the AC 3200-II into a 19" rack:

- ▶ Slide the AC 3200-II into the 19" rack.
- ▶ Secure the rack mount "ears" to the rack using four screws (to be ordered separately).



## Switching the AC 3200-II on and off

### To switch on the antenna combiner:

- ▶ Press the on/off switch.
- ✓ The AC 3200-II switches on and the LED lights up red.
- ▶ Press the on/off switch again

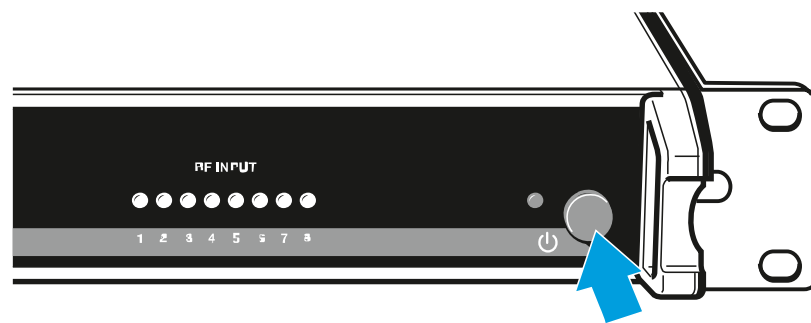

- ✓ The AC 3200-II switches off and the LED  goes off.

**i** After switch-off, the AC 3200-II is in standby mode. To disconnect the device and the NT 12-125D mains uni from the mains power supply, pull out the mains connector from the wall socket.

### To fully switch off the antenna combiner:

- ▶ Disconnect the antenna combiner from the power supply system by unplugging the power supply unit from the wall socket.



## RF indicators

The AC 3200-II has 8 control LEDs which light up green on the channels where transmission power is available.

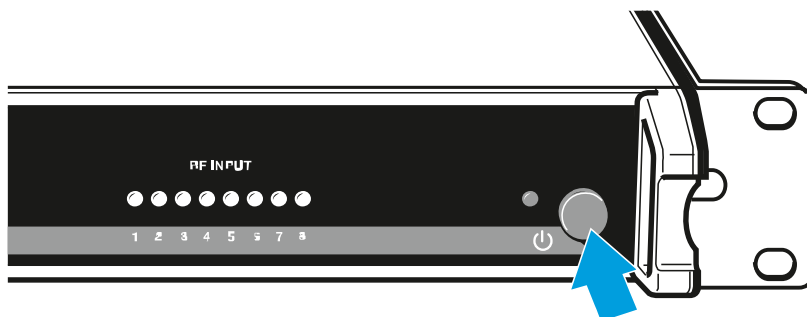



## Recommendations and tips for optimum transmission

- There should be a “free line of sight” between transmitting and receiving antennas.
- To avoid overloading the receiver, observe a minimum distance of 5 m between transmitting and receiving antennas.
- Observe a minimum distance of 50 cm between the transmitting antenna and metal objects (such as cross members or reinforced-concrete walls).
- When using a multi-channel system: Set all transmitters of your multi-channel system to intermodulation-free frequencies.



## Establishing a radio link

To establish a radio link between the transmitter and receiver, the same frequency must be set in both devices.

You can do this in a number of different ways:

- Use the Easy Setup function to perform an automatic frequency setup (see [Easy Setup menu item](#)).
- Set a frequency in the receiver manually (see [Frequency Preset menu item](#)) and synchronize it with the transmitter (see [Synchronizing devices](#)).
- Set the frequency on the receiver and the transmitter manually
  - EK 2000 IEM: [Frequency Preset menu item](#)
  - SR 2000 IEM / SR 2050 IEM : [Frequency Preset menu item](#).

### Setting notes

Please note the following when synchronizing a transmitter with a receivers:

- ▶ Only use transmitters and receivers from the same frequency range (see the type plate on the transmitter and receiver).
- ▶ Make sure that your chosen frequencies are listed in the frequency table for the particular frequency range (see [Frequency tables](#)).
- ▶ Ensure that the desired frequencies are permitted in your country and apply for an operating license if necessary.
- ▶ Please note the general conditions and restrictions for the use of frequencies: [sennheiser.com/sifa](http://sennheiser.com/sifa).



## Synchronizing devices

You can synchronize the 2000 IEM series transmitters and receivers via the transmitter's and receiver's infrared interfaces.

The Easy Setup Sync function makes it possible to transfer unused frequency presets from your EK 2000 IEM receiver to multiple transmitters via the infrared interface after you have performed a Frequency Preset Scan with this receiver. The next unused channel in the receiver's current frequency bank is transferred to your transmitter.

Vice versa, you can use the Sync function to configure the settings for your EK 2000 IEM portable receiver directly on your stationary SR 2000 IEM / SR 2050 IEM transmitter and transfer them to the receivers via the infrared interface.

### Easy Setup Sync function (EK 2000 IEM -> SR 2000 IEM / SR 2050 IEM) for a single radio link

- ▶ Switch your stationary transmitter and your mobile receivers on.
- ▶ Call up the Easy Setup menu item on the transmitter.
- ▶ Choose the **Mute RF For Only This Device?** option.
  - ✓ The SYNC display appears in the transmitter display panel and the blue LED on the infrared interface lights up.



- ▶ Perform a frequency preset scan with your EK 2000 IEM mobile receiver (see [Easy Setup menu item](#)) and select a frequency bank with sufficient unused frequencies.
- ▶ Hold the infra-red interface of the receiver in front of the infra-red interface of the first transmitter.



- ✓ The next unused frequency preset is transferred from the receiver to the transmitter.

Once the transfer is complete, the numbers of the transferred frequency bank and the transferred channel appear in the display panel of the transmitter.

- ▶ Press the **jog dial** on the transmitter to save the synchronized frequency.
- ▶ Hold the infrared interface of the mobile receiver in front of the infrared interfaces of the remaining transmitters one at a time.

#### Easy Setup Sync funktion (EK 2000 IEM -> SR 2000 IEM / SR 2050 IEM) for a multi-channel frequency setup

- ▶ Perform the multi-channel frequency setup as described under [Easy Setup menu item](#).

#### Sync funktion (SR 2000 IEM / SR 2050 IEM -> EK 2000 IEM)

- ▶ You can adjust the Parameter to be transferred to the receivers here: [Advanced > Sync Settings menu item](#).
- ▶ Switch the transmitter and the receiver on.
- ▶ Press the **SYNC** button on the transmitter.
  - ✓ Sync appears in the transmitter's display and the blue LED turns blue.

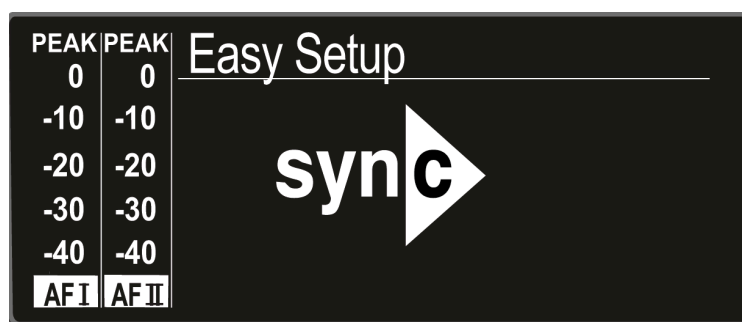

- ▶ Hold the infra-red interface of the receiver in front of the infra-red interface of the transmitter.



- ✓ The parameters are transferred to the receiver. The blue LED blinks during transmission.

When the transfer is complete, a tick appears in the transmitter's display as a confirmation. Then the transmitter will return to the standard display.

- ▶ **To cancel synchronization:** Press the **ESC** button on the transmitter.

- ✓ An X appears on the display.

- ▶ **This icon also appears when:**

- no receiver is found or the receiver is not compatible.
- no receiver is found and the synchronization process automatically ends after 30 seconds.



## Cleaning and maintenance

Note the following information when cleaning and maintaining 2000 IEM series products.

### NOTICE



#### Liquids can damage the electronics of the product

Liquids entering the product housing can cause a short-circuit and damage the electronics.

- ▶ Keep all liquids away from the products.
- ▶ Do not use any solvents or cleansing agents.
- ▶ Disconnect the mains-operated products from the power supply system and remove rechargeable batteries and batteries (if present) before you begin cleaning.
- ▶ Clean all products only with a soft, dry cloth.



## 4. Specifications

All specifications at a glance.

### EK 2000 IEM

#### RF characteristics

<b>Modulation</b>	wideband FM
<b>Receiving frequency ranges</b>	Aw+: 470-558 MHz Gw1: 558 - 608 MHz Gw: 558 - 626 MHz GBw: 606- 678 MHz BW: 626 - 698 MHz
<b>Receiving frequencies</b>	up to 3,000 frequencies, tuneable in steps of 25 kHz  20 frequency banks, each with up to 32 factory-preset channels  6 frequency banks, each with up to 32 factory-preset channels
<b>Switching bandwidth</b>	up to 75 MHz
<b>Nominal/peak deviation</b>	$\pm 24$ kHz / $\pm 48$ kHz
<b>Receiver principle</b>	Adaptive-Diversity
<b>Sensitivity (with HDX, peak deviation)</b>	$< 4$ $\mu$ V, typ. 1.6 $\mu$ V for 52 dBA eff S/N
<b>Adjacent channel rejection</b>	typ. $\geq 80$ dB
<b>Intermodulation attenuation</b>	typ. $\geq 78$ dB
<b>Blocking</b>	$\geq 80$ dB
<b>Squelch</b>	Off, 5 to 25 dB $\mu$ V, in 2-dB-steps
<b>Pilot tone squelch</b>	can be switched off

#### AF characteristics

<b>Componder system</b>	Sennheiser HDX
<b>S/N ratio (1 mV, peak deviation)</b>	approx. 90 dB
<b>THD</b>	$\leq 0,9$ %



<b>Output power at 2.4 V, 5 % THD, nominal deviation</b>	2 x 200 mW at 32 $\Omega$
<b>High Boost</b>	+8 dB at 80 kHz
<b>Limiter</b>	-18 dB to -6 dB, in 3-dB-steps, can be switched off
<b>Overall device</b>	
<b>Temperature range</b>	-10 °C to +55 °C
<b>Power supply</b>	2 batteries Typ Mignon AA 1.5 V or Akkupack BA 2015
<b>Nominal voltage</b>	Batteries 3 V Akkupack 2.4 V
<b>Power consumption</b>	at nominal voltage: approx. 140 mA with switched-off receiver: $\leq 25 \mu\text{A}$
<b>Operating time</b>	approx. 4 to 6 hrs (depending on volume level)
<b>Dimensions</b>	approx. 82 x 64 x 24 mm (3.23" x 2.52" x 0.95")
<b>Weight (incl. batteries)</b>	approx. 140 g (0.31 lbs)



## SR 2000 IEM | SR 2050

### RF characteristics

<b>Frequency ranges</b>	Aw+: 470-558 MHz Gw: 558 – 626 MHz Gw1: 558 – 608 MHz GBw: 606 – 678 MHz Bw: 626 – 698 MHz
<b>Transmission frequencies</b>	up to 3,000 frequencies, tuneable in steps of 25 kHz  20 frequency banks, each with up to 32 factory-preset channels  6 frequency banks, each with up to 32 user programmable channels
<b>Switching bandwidth</b>	up to 75 MHz
<b>Frequency stability</b>	±10 ppm (–10 °C to +55 °C)
<b>Antenna output</b>	BNC socket, 50 Ω
<b>RF output power at 50 Ω</b>	typ. 10/30/50 mW (Low/Standard/High)  switchable typ. 100 mW (SR 2050XP IEM)

### AF characteristics

<b>Modulation</b>	wideband FM stereo (MPX pilot tone)
<b>Comander system</b>	Sennheiser HDX
<b>Nominal/peak deviation</b>	±24 kHz / ±48 kHz
<b>MPX pilot tone (frequency/ deviation)</b>	19 kHz / ±5 kHz
<b>AF frequency response</b>	25 – 15,000 ;Hz
<b>AF input BAL AF IN L (I)/BAL AF IN R (II)</b>	2 x XLR-3/¼" (6.3 mm) jack combo socket, electronically balanced
<b>Max. input level</b>	+22 dBu
<b>THD (at 1 kHz and nominal deviation)</b>	≤ 0,9 %
<b>Signal-to-noise ratio at nominal load and peak deviation</b>	> 90 dB



**AF output LOOP OUT BAL L (I)/LOOP OUT BAL R (II)** ¼" (6.3 mm) stereo jack socket, balanced

**Overall device**

**Temperature range** -10 °C to +55 °C

**Power supply** 100 – 240 V AC

**Current consumption** 0.2 A

**Dimensions** approx. 217 x 483 x 43 mm (8.54" x 19.02" x 1.69")

**Weight** approx. 2,700 g (5.95 lbs)



## AC 3200-II

<b>Receiving frequency ranges</b>	500 to 870 MHz
<b>Distribution attenuation</b>	AC 3200-II: 0 dB ( $\pm 1$ dB) AC 3200-II High Gain: +3 dB ( $\pm 1$ dB)
<b>RF input power</b>	max. 100 mW
<b>Inputs protected up to</b>	max. 250 mW
<b>Impedance</b>	50 $\Omega$
<b>Power supply</b>	12 V DC
<b>Current consumption</b>	max. 7.5 A
<b>Power consumption</b>	max. 90 W
<b>Temperature range</b>	-10 °C to +45 °C
<b>Weight</b>	approx. 4 kg
<b>Dimensions</b>	436 x 215 x 44 mm

## NT 12-125D

<b>Type</b>	Mean Well GST160A12
<b>Input voltage</b>	100 to 240 V AC
<b>Input frequency</b>	50 to 60 Hz
<b>Current consumption</b>	max. 1.85 A
<b>Output voltage</b>	12 V DC
<b>Output current</b>	max. 11.5 A
<b>Temperature range</b>	-30 °C to +50 °C
<b>Relative air humidity</b>	20 to 90%
<b>Gewicht</b>	approx. 660 g (without mains cable)
<b>Dimensions</b>	175 x 72 x 35 mm
<b>Length of DC output cable</b>	approx. 100 cm/39"



## IE 500 PRO earphones

<b>Frequency response</b>	6 – 20,000 Hz
<b>Impedance</b>	16 $\Omega$
<b>Sound pressure level</b>	126 dB (1 kHz / 1 V rms)
<b>Total harmonic distortion (THD)</b>	< 0.08 % (1 kHz, 94 dB)
<b>Noise attenuation</b>	< 26 dB
<b>Magnetic field strength</b>	2 mT
<b>Temperature</b>	
Operation:	-5 °C to +50 °C (23 °F to 122 °F)
Storage:	-20 °C to +70 °C (-4 °F to 158 °F)
<b>Relative humidity</b>	< 95%



## IE 400 PRO earphones

<b>Frequency response</b>	6 – 19,000 Hz
<b>Impedance</b>	16 $\Omega$
<b>Sound pressure level</b>	123 dB (1 kHz / 1 V rms)
<b>Total harmonic distortion (THD)</b>	< 0.08 % (1 kHz, 94 dB)
<b>Noise attenuation</b>	< 26 dB
<b>Magnetic field strength</b>	2 mT
<b>Temperature</b>	
Operation:	-5 °C to +50 °C (23 °F to 122 °F)
Storage:	-20 °C to +70 °C (-4 °F to 158 °F)
<b>Relative humidity</b>	< 95%



## IE 4 earphones

<b>Frequency ranges</b>	40 – 20,000 Hz
<b>Max. sound pressure level</b>	118 dB SPL
<b>Sound pressure</b>	106 dB (1 kHz / 1 V rms)
<b>Impedance</b>	32 $\Omega$
<b>Nominal impedance</b>	16 $\Omega$
<b>Cable length</b>	1.4 m
<b>Connector</b>	3.5 mm stereo plug, gold-plated



## Pin assignment

### 3.5 mm stereo jack plug

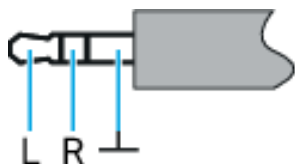

Plug for headphone and earphone cables, e. g. IE 4.

Connect to:

- EK 2000 IEM
- EK IEM G4
- XSW IEM EK

### 6.3 mm stereo jack plug, balanced (audio in/loop out)

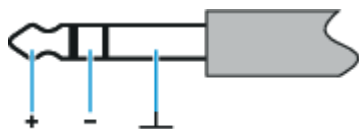

Connect to:

- SR 2000 IEM / SR 2050 IEM Audio In
- SR 2000 IEM / SR 2050 IEM Loop Out
- SR IEM G4 Audio In
- SR IEM G4 Loop Out
- XSW IEM SR Audio In
- XSW IEM SR Loop Out

### 6.3 mm stereo jack plug for headphone connector

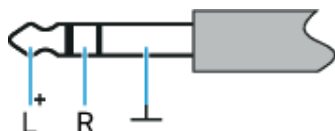

Connect to:

- SR 2000 IEM / SR 2050 IEM headphone input
- SR IEM G4 headphone input
- XSW IEM SR headphone input



XLR-3 plug, balanced

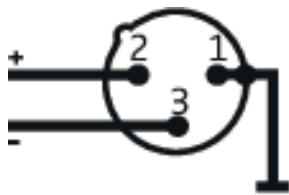



## 5. Regulatory Information

Information on manufacturer declarations, environmental and disposal notices, and terms of use.

Model: SR 2050 IEM, SR 2050XP IEM, EK 2000 IEM

### Conditions and restrictions for using frequencies

There may be special conditions and restrictions for using frequencies in your country.

Before putting the product into operation, find the information for your country at the following address: [sennheiser.com/sifa](https://www.sennheiser.com/sifa).

### Warranty

Sennheiser electronic SE & Co. KG gives a warranty of 24 months on these products.

For the current warranty conditions, please visit our website at [sennheiser.com](https://www.sennheiser.com) or contact your Sennheiser partner.

In the US please contact:

Sennheiser Electronic Corporation

1 Enterprise Drive, Old Lyme, CT 06371

[www.sennheiser.com](https://www.sennheiser.com)

### Warranty for Australia and New Zealand only

Sennheiser Australia Pty Ltd provides a warranty of 24 months on these products. For the current warranty conditions, visit Sennheiser website: Australia: [sennheiser.com](https://www.sennheiser.com), New Zealand: [sennheiser.com](https://www.sennheiser.com)

Sennheiser goods come with guarantees that cannot be excluded under Australian and New Zealand Consumer law. You are entitled to a replacement or refund for a major failure and compensation for any other reasonably foreseeable loss or damage. You are also entitled to have the goods repaired or replaced if the goods fail to be of acceptable quality and the failure does not amount to a major failure.

This warranty is in addition to other rights or remedies under law. Nothing in this warranty excludes, limits or modifies any remedy available to be consumer which is granted by law.

To make a claim under this contract, raise a case via Sennheiser website. Australia: [sennheiser.com/support](https://www.sennheiser.com/support), New Zealand: [sennheiser.com/support](https://www.sennheiser.com/support)

All expenses of claiming the warranty will be borne by the person making the claim.



Sennheiser international warranty is provided by: Sennheiser Australia Pty Ltd (ABN 68 165 388 312) Level 14, Tower A Zenith Building, 821 Pacific Highway, Chatswood NSW 2067, Australia

**Europe**



**In compliance with the following requirements**

- Regulation (EU) 2023/988 on general product safety
- WEEE Directive (2012/19/EU)
- Regulation (EU) 2023/1542 concerning batteries and waste batteries



**Italy:**

Raccolta carta



Raccolta plastica



**France:**



**FR**

Carton d'emballage  
 + Sac plastique PE  
 + Mousse en PE  
 + Notice d'emploi en papier



**Notes on disposal**

The symbol of the crossed-out dumpster on the product, the (rechargeable) battery (if applicable) and/or the packaging indicates that these products must not be disposed of with normal household waste, but must be disposed of separately at the end of their service life. For the packaging, follow the regulations in your country for separating waste. Improper disposal of packaging materials can be harmful to your health and the environment.

The separate collection of waste electrical and electronic equipment, (rechargeable) batteries (if applicable) and packaging is intended to promote reuse and recycling and to prevent negative impacts on public health and the environment, for example due to hazardous substances contained in these products. At the end of their service life, recycle electrical and electronic equipment and (rechargeable) batteries so that their materials can be reused and to prevent environmental pollution.

If (rechargeable) batteries can be removed without destroying them, you are obliged to dispose of them separately (see the product's operating instructions for information on how



to remove the batteries safely). Be especially careful when handling (rechargeable) batteries containing lithium, as these pose special hazards, such as the risk of fire and/or health risks if button cells are swallowed. Reduce battery waste as much as possible by using longer-life batteries or rechargeable batteries.

Further information on the recycling of these products can be obtained from your municipal administration, from the municipal collection points, or from your Sennheiser partner. You may also be able to return electrical or electronic equipment to your distributor, if they are legally required to do so. By disposing of your batteries properly, you are helping to protect public health and the environment.

#### EU Declaration of conformity

- RoHS Directive (2011/65/EU)

Hereby, Sennheiser electronic GmbH & Co. KG declares that the radio equipment type SR 2050 IEM, EK 2000 IEM is in compliance with Directive 2014/53/EU.

The full text of the EU declaration of conformity is available at the following internet address: [sennheiser.com/download](https://sennheiser.com/download).

#### United Kingdom



#### In compliance with the following requirements

- WEEE Regulations (2013)
- Battery Regulations (2015)



#### UK Declaration of conformity

- RoHS Regulations (2012)
- Radio Equipment Regulations (2017)

Importer: Sennheiser UK Ltd.

Pacific House, Third Avenue, Globe Park, Marlow

Buckinghamshire SL7 1EY, United Kingdom

#### USA





### **Statements regarding FCC and ISED**

This device complies with part 15 of the FCC rules and RSS-210 / ICES-003 of Industry Canada. Operation is subject to the following two conditions: (1) this device may not cause harmful interference, and (2) this device must accept any interference received, including interference that may cause undesired operation.

This equipment has been tested and found to comply with the limits for a Class B digital device, pursuant to part 15 of the FCC Rules. These limits are designed to provide reasonable protection against harmful interference in a residential installation. This equipment generates, uses and can radiate radio frequency energy and, if not installed and used in accordance with the instructions, may cause harmful interference to radio communications. However, there is no guarantee that interference will not occur in a particular installation. If this equipment does cause harmful interference to radio or television reception, which can be determined by turning the equipment off and on, the user is encouraged to try to correct the interference by one or more of the following measures:

- Reorient or relocate the receiving antenna.
- Increase the separation between the equipment and receiver.
- Connect the equipment into an outlet on a circuit different from that to which the receiver is connected.
- Consult the dealer or an experienced radio/ TV technician for help.

This Class B digital device complies with the Canadian ICES-003.

Changes or modifications not expressly approved by Sennheiser electronic Corp. could void the user's authority to operate the equipment.

Before putting the device into operation, please observe the respective country-specific regulations!

### **RSS-210 Issue 9 Annex G.1**

This device operates on a no-interference, no-protection basis. Should the user seek to obtain protection from other radio services operating in the same TV bands, a radio licence is required. For further details, consult Innovation, Science and Economic Development Canada's Client Procedures Circular CPC-2-1-28, Voluntary Licensing of Licence-Exempt Wireless Microphones in the TV Bands.

### **Radiofrequency radiation exposure Information**

This equipment complies with FCC and IC radiation exposure limits set forth for an uncontrolled environment. The SR 2050 IEM and SR 2050XP IEM should be installed and operated with a minimum distance of 20 cm between the radiator and your body.

Contact information: Sennheiser Electronic Corporation, 1 Enterprise Drive, Old Lyme, CT 06371; [sennheiser.com](http://sennheiser.com)

SR 2050 IEM, SR 2050XP IEM: FCCPart 74

FCCID: DMOSR2050 limited to 608 MHz

EK 2000 IEM: 47 CFR 15 subpart B



## Canada

### Statements regarding FCC and ISCED

This device complies with part 15 of the FCC rules and RSS-210 / ICES-003 of Industry Canada. Operation is subject to the following two conditions: (1) this device may not cause harmful interference, and (2) this device must accept any interference received, including interference that may cause undesired operation.

This equipment has been tested and found to comply with the limits for a Class B digital device, pursuant to part 15 of the FCC Rules. These limits are designed to provide reasonable protection against harmful interference in a residential installation. This equipment generates, uses and can radiate radio frequency energy and, if not installed and used in accordance with the instructions, may cause harmful interference to radio communications. However, there is no guarantee that interference will not occur in a particular installation. If this equipment does cause harmful interference to radio or television reception, which can be determined by turning the equipment off and on, the user is encouraged to try to correct the interference by one or more of the following measures:

- Reorient or relocate the receiving antenna.
- Increase the separation between the equipment and receiver.
- Connect the equipment into an outlet on a circuit different from that to which the receiver is connected.
- Consult the dealer or an experienced radio/ TV technician for help.

This Class B digital device complies with the Canadian ICES-003.

Changes or modifications not expressly approved by Sennheiser electronic Corp. could void the user's authority to operate the equipment.

Before putting the device into operation, please observe the respective country-specific regulations!

### RSS-210 Issue 9 Annex G.1

This device operates on a no-interference, no-protection basis. Should the user seek to obtain protection from other radio services operating in the same TV bands, a radio licence is required. For further details, consult Innovation, Science and Economic Development Canada's Client Procedures Circular CPC-2-1-28, Voluntary Licensing of Licence-Exempt Wireless Microphones in the TV Bands.

### Radiofrequency radiation exposure Information

This equipment complies with FCC and IC radiation exposure limits set forth for an uncontrolled environment. The SR 2050 IEM and SR 2050XP IEM should be installed and operated with a minimum distance of 20 cm between the radiator and your body.

SR 2050 IEM, SR 2050XP IEM: Industry Canada RSS 210

IC: 2099ASR2050 limited to 608 MHz

EK 2000 IEM: CAN RSSGen / CNRGen



### Australia / New Zealand

SR 2050 IEM, SR 2050XP IEM



### Australia

EK 2000 IEM



### Brazil

SR 2050 IEM, SR 2050XP IEM



054041907356

Este equipamento não tem direito à proteção contra interferência prejudicial e não pode causar interferência em sistemas devidamente autorizados.

Para maiores informações, consulte o site da ANATEL

[www.gov.br/anatel/pt-br](http://www.gov.br/anatel/pt-br)

